

HYTROL CONVEYOR COMPANY, INC.

Model **190-E24** 24 VDC Live Roller



190-E24 and 190-E24C shown together.

The model 190-E24 24 VDC Live Roller Conveyor uses a series of 24 VDC motors to drive the tread rollers, eliminating the need for drive belts, chains, or line shafts. Quiet operation and ease of maintenance and installation are just some of the advantages.

- All-Electric Operation
- Adjustable MS-Type Floor Supports Available

Section Length	Between Rail Width	9"	11"	13"	15"	17"	19"	21"	23"	25"	27"	31"	33"	37"	39"
	Overall Frame Width	12"	14"	16"	18"	20"	22"	24"	26"	28"	30"	34"	36"	40"	42"
10'-0"	Weights (lbs.)	285	300	310	325	340	355	370	385	400	410	435	450	480	495
Per Foot	Weights (lbs.)	16	17	19	20	21	23	24	26	27	28	31	32	35	36

NOTE: Section Lengths are available from 2 ft. to 10 ft, in 6 in. increments.

NOTE: Motors are mounted on various centers, and will slave a maximum of 16 rollers. Includes: motor, control board, o-rings, frame and slaved rollers.

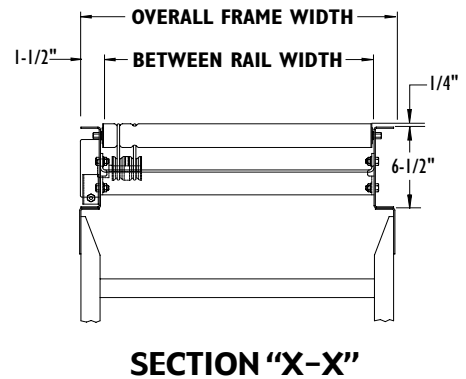
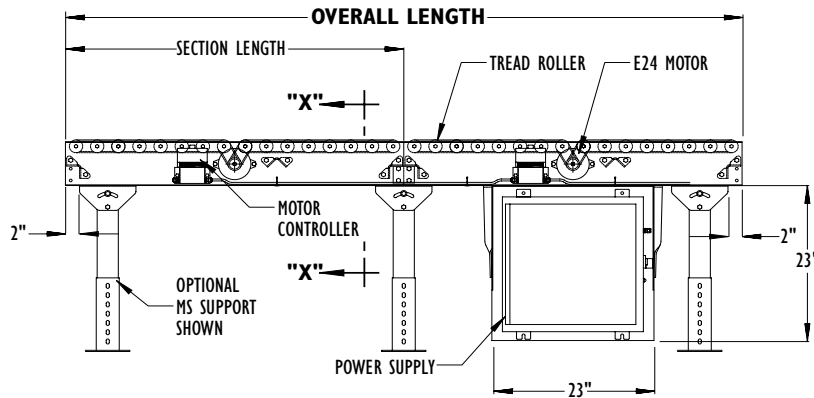

LIVE ROLLER

Model **190-E24C** 24 VDC Live Roller Curve Conveyor

Between Rail Width	Overall Frame Width	"R"	Number of Rollers	WEIGHTS (Lbs.)
15"	18"	32-1/2"	20	220
17"	20"			240
19"	22"			260
21"	24"			280
23"	26"			300
25"	28"			310
27"	30"	48"	30	325
31"	34"			495
33"	36"			520
37"	40"			565
39"	42"			590

- All-Electric Operation
- Adjustable MS-Type Floor Supports Available

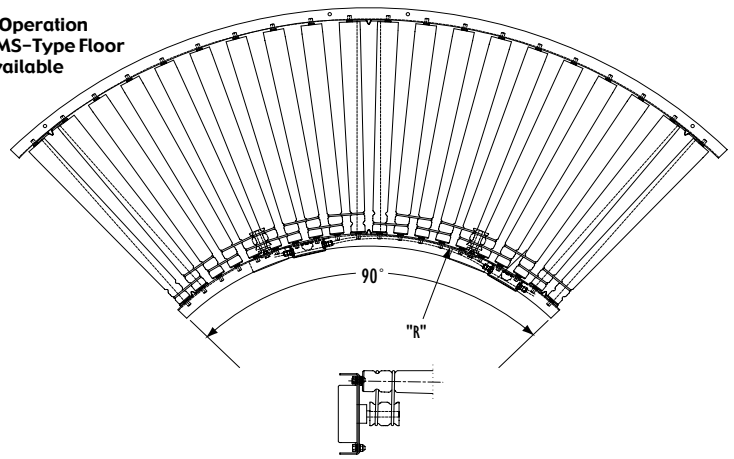

All weights in catalog are conveyor weights only. Accessories, crating, etc., are not included.

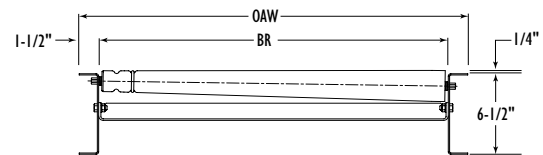

• Standard Specifications

Model **190-E24**

BED (E24)—Roller bed with 1.9 in. dia. roller x 16 ga. galvanized tube and bearings spaced every 3 in. Mounted set-high in 6-1/2 in x 12 ga. powder painted formed steel channel frame bolted together with splice plates.

BED (E24C)—Roller bed with 2-1/2 in. dia tapered to 1-11/16 in. dia. x 16 ga. galvanized rollers. Mounted in 6-1/2 x 12 ga. powder painted formed steel channel frame.

MOTOR—24 VDC motor located along section. Maximum slaved: 16 rollers per each motor.

SLAVE O-RINGS—3/16 in. dia. polyurethane o-rings slave-drive tread rollers from motor.

MOTOR CONTROLLER—Controls and protects motor. One per each motor.

POWER SUPPLY (FOR MOTORS)—40 amp DC power supply, 28 volt fixed output. Maximum of 40 motors per power supply. 120 vac, 17 amp input. Mounted near center of conveyor. **NOTE:** Number of motors per power supply is based on the use of standard Hytrol o-rings. Other o-rings are available that may increase load capacity, but reduce the number of motors that may be powered from one power supply. Contact factory for more information.

CONVEYING SPEED—35-125 FPM, set on motor controller.



Rollers are powered by 24 VDC motors. The rollers are driven from the motor with o-rings.



CAPACITY—Maximum 37 lbs. per foot with a maximum capacity per E24 motor of 75 lbs. If loading product “back to back” use the following chart:

SECTION LENGTH	NUMBER OF MOTORS IN SECTION	CAPACITY (LBS PER FOOT)
2'-0"	1	37
2'-6"		30
3'-0"		25
3'-6"		21
4'-0"		19
4'-6"	2	33
5'-0"		30
5'-6"		27
6'-0"		25
6'-6"		23
7'-0"	3	21
7'-6"		20
8'-0"		19
8'-6"		26
9'-0"		25
9'-6"	23	
10'-0"		22

NOTE: Capacity is based on the use of standard Hytrol o-rings. Other o-rings are available that may increase load capacity, but reduce the number of motors that may be powered from one power supply. Contact factory for more information.

FLOOR SUPPORTS—Now supplied as optional equipment.



Cisco-Eagle

www.cisco-eagle.com • 888-877-3861 toll free

• Optional Equipment

FLOOR SUPPORTS—MS Type floor supports are available with a wide range of adjustment. Specify top of belt or roller elevation. One support required at every bed joint and ends of conveyor. Holes in feet for lagging to floor. Knee braces recommended above MS-6 support.

POWER SUPPLY (MOTORS)—20 Amp power supply available. 20 motors maximum.

POLY-TIER SUPPORTS—36 in. to 120 in. support heights in 6 in. increments. Knee braces required.

CEILING HANGERS—5/8 in. dia. x 8 ft. long unplated steel rods fully threaded. Other lengths and galvanized rods available.

GUARD RAILS—Adjustable Universal Channel Guard Rail, type A & B angle. (See Accessory section.) **NOTE:** If product comes in contact with guard rails, product flow will be affected.

ROLLER—1.9 in. dia. roller x 16 ga. galvanized tube with ABEC-1 precision bearing.

HIGH-SPEED DRIVE SPOOL—Provides a speed range of 50-200 FPM.

MINIMUM PRESSURE OPTION—Allows the 190-E24 to operate as a minimum-pressure conveyor. Contact factory for details.

