

HYTROL CONVEYOR COMPANY, INC.

Model **36-CREZD** Heavy Duty Accumulating Conveyor (Zero Pressure Accumulating Type)

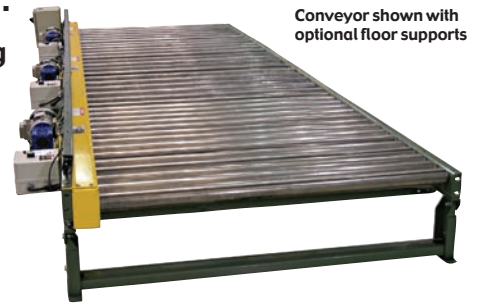

Conveyor shown with optional floor supports

The Model 36-CREZD is a heavy duty chain driven live roller conveyor designed for zero pressure accumulation of products. This conveyor is designed to handle heavily loaded containers, racks, or pallets. Products may be accumulated in zones and released upon request.

- EZDrive™ System (Individual zone drive)
- EZLogic® Accumulation System
- Chain Driven Rollers
- Shaft Mounted Drives
- HSF-Type Floor Supports Available



U.S. Patent Numbers
6,860,381 and 5,862,907
Other Patents Pending

Conveying Surface	27-3/4"	31-3/4"	35-3/4"	39-3/4"	43-3/4"	47-3/4"	51-3/4"	55-3/4"	59-3/4"	63-3/4"
Between Rail Width	31"	35"	39"	43"	47"	51"	55"	59"	63"	67"
Overall Frame Width	34-1/4"	38-1/4"	42-1/4"	46-1/4"	50-1/4"	54-1/4"	58-1/4"	62-1/4"	66-1/4"	70-1/4"
Weight Per Foot 6" Centers	115	123	131	139	147	155	163	171	179	187

HOW IT WORKS

The conveyor is made up of accumulation zones. Each zone contains an individual zone drive interfaced to Hytrol's EZLogic® Zone Controllers, which sense product presence and control the accumulation and release of the zones by starting and stopping the zone drives.

Total Weight = (Number of Zones x 35) + (OAL x Weight per Foot)

All weights in catalog are conveyor weights only. Accessories, crating, etc. are not included.

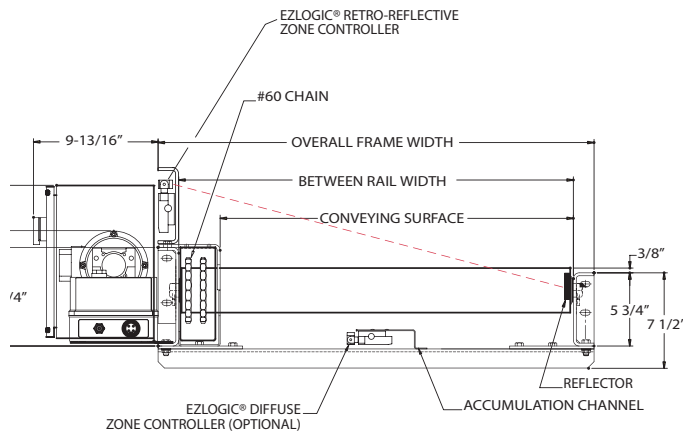
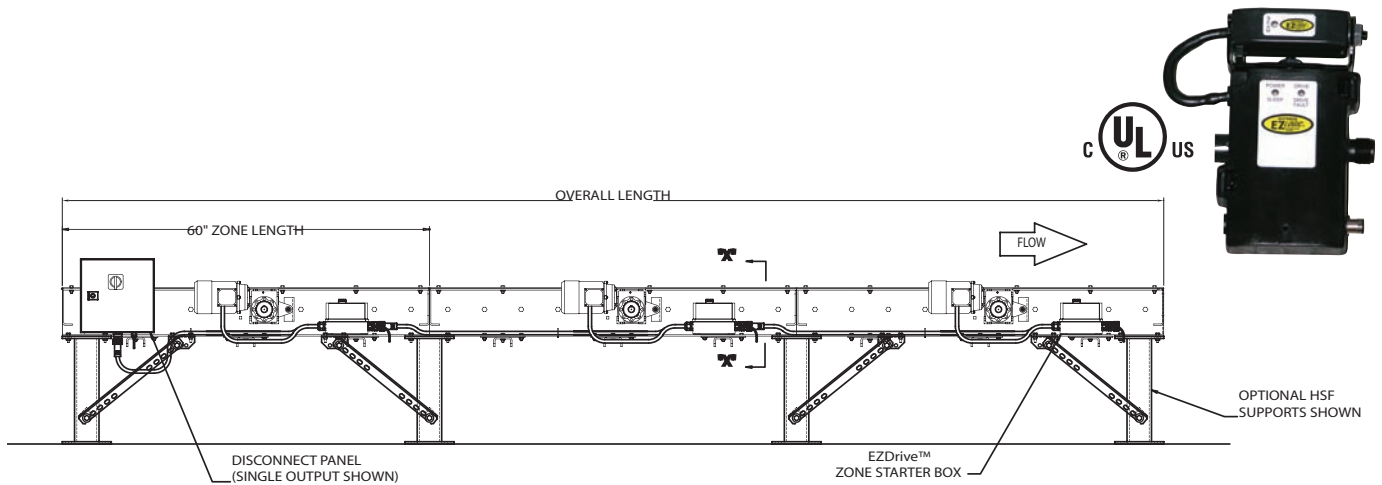

VIEW X-X
DISCONNECT PANEL

ACCUMULATION - ZERO PRESSURE



• Standard Specifications

Model 36-CREZD

BED-Roller bed with 3-1/2 in. dia. x .300 wall unplated rollers spaced every 6 in. Tread rollers mounted in 5-3/4 in. x 4 ga. channel on side opposite chain guard and 7-3/4 in. x 4 ga. channel on chain guard side. Bolted together with butt couplings.

DRIVE CHAIN-No. 60 roller-to-roller.

CHAIN GUARD-Formed steel guards totally enclose drive chains.

BEARINGS-Sealed, pre-lubricated ball bearings.

EZDrive™ System-Shaft mounted gearmotor located near center of each zone. 1/2 HP - 3 PH 60 Hz. Totally enclosed fan cooled. 230 or 460 V (specify voltage). Includes EZDrive™ Disconnect Panel. Power is distributed zone to zone through pluggable cordsets. Power is connected from the starter box to the motor via "SO" type cord. Please contact factory if local code requires other than the standard power distribution techniques described.

ACCUMULATION ZONE LENGTHS-60 in., 72 in., 84 in., 96 in., 108 in., 120 in. Frame lengths will change with zone lengths.

EZLOGIC® ZONE CONTROLLER-Located in each zone (Diffuse). NEMA 1, 2, IP 62. UL Approved.

IOP-Provides 27VDC, 100 watt power for EZLogic® accumulation system - contains slots for 4 input/output boards. Should be located near disconnect panel. See chart for maximum quantity of zones. Requires 120VAC or 230VAC single phase input.

CONVEYING SPEED-Constant 26.5 FPM.

CAPACITY-Maximum load per linear foot of conveyor 2000 lbs. Maximum unit load 5000 lbs per zone. Zones longer than 6 ft. may require an additional floor support depending on product load.

FLOOR SUPPORTS-Now supplied as optional equipment.

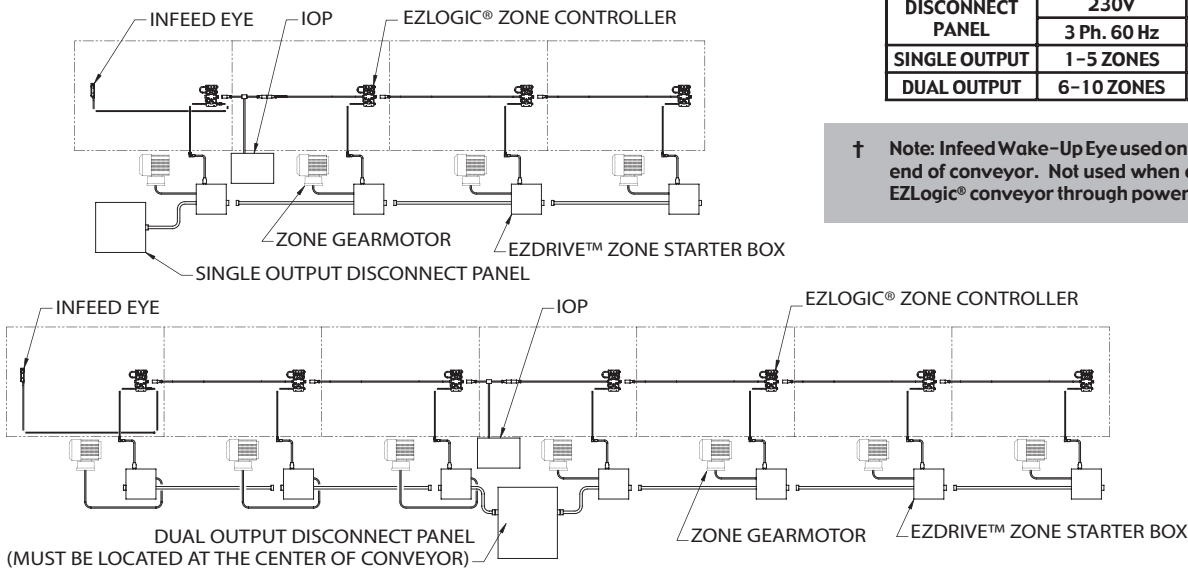

DISCONNECT PANEL	230V	460V
		3 Ph. 60 Hz
SINGLE OUTPUT	1-5 ZONES	1-10 ZONES
DUAL OUTPUT	6-10 ZONES	11-20 ZONES

† Note: Infeed Wake-Up Eye used only on terminating infeed end of conveyor. Not used when connecting to upstream EZLogic® conveyor through power supply isolation cable.

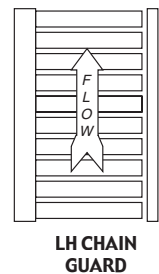
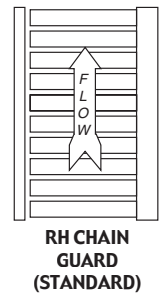

EZLOGIC® ACCUMULATION SYSTEM

Hytrol's EZLogic®, or "Electronic Zero-pressure Logic" Accumulation System, combines the sensing accuracy of photo-electronics with discrete electronic logic control without the use of a PLC or pneumatic logic components. The EZLogic® Accumulation System provides many features including:

Zero-Pressure Accumulation of Product

Zone Stop - Function is built in. Any zone may be transformed into a workstation by connecting a dry contact switching device to the auxiliary port of the EZLogic® Zone Controller. This feature is always used at the discharge end of the conveyor line, and may be used at any other location where a zone stop is required.

Dynamic Zone Allocation - Automatically adjusts the conveyor's zone length to accommodate the length of the product being conveyed. Improves conveyor efficiency and system flexibility.

Sleep Feature - Stops tread rollers from turning when no product is present, reducing noise, reducing energy consumption and extending roller bearing life.

Unloading Zone Feature - Zone On Delay - Timer delays the zone immediately upstream from a removed load, preventing it from driving for a set time. This feature is ideal where loads are routinely removed from the conveyor with a lift truck.

Loading Zone Feature - Zone detects load being placed onto the conveyor with a fork truck and stops the zone from driving and automatically prevents any loads in zones upstream from entering loading area.

• Optional Equipment

FLOOR SUPPORTS-HSF Type floor supports are available for a wide range of elevations. Specify top of roller elevation. One support required at every bed joint and ends of conveyor. Holes in feet for lagging to floor. Includes knee braces HSF-11 and above.

CONVEYING SPEED-Other constant and variable speeds available, contact factory.

EZDrive® System:

- Variable Frequency Drive for adjusting conveying speed or adjusting acceleration and deceleration time.
- Soft Start Box for adjusting acceleration and deceleration time.

EZLogic® - See EZLogic® Components Page.

