

XL, X3W & X4W Series Scissor Lifts

Installation, Operation and Service Manual

Model Number _____

Serial # _____

Date placed in service _____

**IMPORTANT: READ CAREFULLY
BEFORE INSTALLING OR OPERATING LIFT**

Part orders are subject to a \$50 minimum charge.



This manual was current at the time of printing. To obtain the latest, most updated version, please contact Presto Lifts Customer Service Department or go to our website: www.PrestoLifts.com -- you will find a complete list of current owner's manuals to print.

CONTENTS

SECTION 1:	
Introduction	4
SECTION 2:	
Safety	4
SECTION 3:	
A. Installation	5
B. Installing	
C. Electricals	
D. Hydraulics	
E. Testing the Lift with No Load	
SECTION 4:	
Operation	6
A. Method of Operation	
B. Operation Procedures	
SECTION 5:	
Maintenance	7
A. Routine Maintenance	
B. Troubleshooting Maintenance	
SECTION 6:	
Service	8
A. Replacing Cylinder Seals	
B. Replacing Leg Rollers	
SECTION 7:	
Troubleshooting	9

LIST OF FIGURES :

Maintenance Chock (Figure 1)	9
XL Scissor Lifts (Figure 3)	10
Exposed Cylinder Assembly (Figure 4)	11
Exposed PowerPack (Figure 5)	11
Recommended Spare Parts List	12
Wiring Schematic 115/1/60 power with 20 AMP Plug (Figure 6)	14
Wiring Schematic 208, 220, 460/3/60 Power with Pig Tail (Figure 7)	14
Hydraulic Schematic for all Models (Figure 8)	15
RESTOCKING POLICY & RMA POLICY	16
RETURN GOODS AUTHORIZATION (RMA) PROCEDURES	17
WARRANTY	20

SECTION 1

INTRODUCTION

This manual attempts to provide all of the information necessary for the safe and proper installation, operation and maintenance of Presto Lifts Inc. XL, X3W or X4W Series Scissor Lifts. It is important that all personnel involved with the installation, maintenance or operation of the scissor lift read this manual. Where unique situations arise, that are not covered in this manual, call Presto Lifts for further instructions. Additional manuals are available upon request or on our web site at www.prestolifts.com.

The scissor lift has a nameplate that provides the load capacity ratings, serial number and model identifications. Please refer to these numbers when ordering parts or requesting further information.

The Presto Lifts XL, X3W or X4W lifts are designed for lifting, lowering and positioning a variety of loads. **WHERE UNIQUE SITUATIONS ARISE, THAT ARE NOT COVERED IN THIS MANUAL, CALL PRESTO LIFTS FOR FURTHER INSTRUCTIONS.**

The XL, X3W or X4W Series is designed for inplant/nonhazardous location use only. These units are not for personnel lifting.

SECTION 2

SAFETY

The safety of all persons installing, using, servicing, or working near the unit is of paramount concern to Presto Lifts. The lift is a powerful machine with moving parts, and is **capable of causing personal injury if proper precautions are not taken**. Therefore, throughout this manual, Presto Lifts has identified certain hazards, which may occur in the use of the unit, and provided appropriate **instructions** or precautions that should be taken to avoid these hazards. In some cases, Presto Lifts' has also pointed out the **consequences** that may occur if Presto Lifts' instructions or precautions are not followed. Presto Lifts uses the following nationally recognized system for identifying the severity of the hazards associated with its products:

DANGER – Immediate hazard that will result in severe personal injury or death.

WARNING – Hazard or unsafe practice, that could result in severe personal injury or death.

CAUTION – hazard or unsafe practice, that could result in minor personal injury or property damage.

In the interest of safety, please read the entire manual carefully. You must understand the material in this manual before you install, use, or service the unit. If you have any question about any of the instructions in this manual, please contact Presto Lifts Inc. at 1-800-343-9322.

SECTION 3

INSTALLATION

A. INSPECTION:

Upon receipt of the XL, X3W or X4W Series Scissor Lift, inspect the equipment completely to determine if there is any shipping damage, and that the lift is complete. Presto Lifts Inc. tests and inspects every piece of equipment prior to shipment. If damage is apparent, a freight claim must be filed with the freight company. Do Not use the lift if there appears to be any damage. With the lift in a collapsed position, check the following:

- ? Check for signs of damage especially to the electrical and hydraulic components.
- ? Check all connections for tightness. Is there hydraulic fluid visible?
- ? Check base frame for flatness.
- ? Inspect for any bent or damaged metal parts.

B: INSTALLING

Before starting, be sure that the electrical system is wired and is in full compliance with local electrical codes and ordinances. Read all of the instructions prior to starting the lift.

1. Floor Installation

- a). Make sure that the floor in the installation area is level, stable and free from dirt and surface defects.
- b). Place lift in exact operating position.

CAUTION!

When moving the lift, do not ever attempt to pick it up by the platform. The lift should be picked up by the base frame only. The use of a strap sling is suggested. If the lift has optional lifting eyebolts, attach a chain spreader and raise the lift from a center position. Be sure the eyebolts are secured in place with locking nuts prior to lifting.

- c). Make sure that the complete base of the lift is in contact with the floor. In order to provide complete contact with the floor, the base may be shimmed or grouted.

CAUTION!

Do not spot shim. The complete base must be in contact with the floor or shims.

- d). If the lift is provided with anchor holes or brackets, be sure the lift has been placed in the exact operating position before spotting or drilling holes for anchor bolts. Bolt the lift securely before using it.
- e). For lifts with remote power units, locate and bolt the power unit in place, so as to provide easy access. Do not obstruct the operator's work area. Make hydraulic connections according to the information contained in Section 3D.
- f). Electrical connections must be made according to the electrical schematics and information contained in Section 3C and in compliance to local codes and ordinances.

1. Pit Mounted Installation

- a). Build pit to standard pit dimension as outlined in Figure 2, Page 6, paying careful attention to raceway, sump, clearance and height requirements.
- b). The remaining steps are the same as required for floor installation. See Section 3B (1b to 1f).

WARNING!

Do not install lifts in pits unless they have approved bevel edge top or electro-mechanical toe guards.

CAUTION!

Lifts with toeguard and oversized platforms must be secured with at least 4 anchor bolts with a minimum of 2000-lb pullout strength for each bolt.

C. ELECTRICALS:

The motors on XL, X3W or X4W Scissor Lifts are special intermittent duty motors with high pull up torques. These motors require heavier duty electrical controls than standard motors.

CAUTION!

All wiring must conform to local codes and must be performed by licensed electricians.

The following chart recommends power sources for various motors supplied with Scissor Lifts.

MOTOR SIZE	FUSE	BREAKER
1 HP 120 Volt 1 PH	25 AMP	20 AMP
1 HP 240 Volt 1 PH	25 AMP	20 AMP
1-1/2 HP 208-240 Volt 3 PH	15 AMP	10 AMP
1-1/2 HP 460 Volt 3 PH	7-1/2 AMP	5 AMP

Schematics for wiring motors:

Figure 6 for 120 volt 1 PH

Figure 6 for 240 volt 1 PH

Figure 7 for 208/240/460 volt 3 PH

WARNING!

Do not tamper with or remove cover of the electrical junction box. Only authorized, qualified personnel should service the electrical system.

D. HYDRAULICS:

1. Use hydraulic oil only for the lift. The lift has been supplied with Citgo AW32.
2. Before using the lift, check the hydraulic oil level and add oil if necessary. Check fittings for tightness. Remove the solid plug on the reservoir and replace it with the vented plug provided. If the plug is not installed, you may damage the pump.
3. External power pack units also require that the hydraulic lines be blown out with clean air. Then attach to hydraulic fittings per hydraulic schematic. Figure 8.

CAUTION!

XL, X3W or X4W Scissor Lifts are designed for normal factory environments. Where below freezing conditions may exist, special fluid must be used. Contact Presto Lifts for further information when freezing conditions exist.

WARNING!

Do not use automotive hydraulic, brake or trans-

mission fluids. They will damage seals and pose a serious fire hazard.

E. TESTING THE LIFT WITH NO LOAD:

1. Before testing the lift, clear the area of any loose material. Be sure the lift has no obstruction above it or on any side. Using the controls provided, briefly operate the lift (5-10 seconds). If the lift begins to rise with a humming sound and functions properly, continue to the full upright position.

CAUTION!

If the lift does not rise immediately, or there is any operational problem, stop it immediately. Before continuing, check the rotation of the pump and motor and the voltage at motor terminals; again briefly operate the lift. If the lift does not move smoothly with a humming sound, stop and review the procedures in the section on troubleshooting (5B).

2. After raising the lift completely, lower the lift. It should move slowly and smoothly without a humming sound. If the lift operates properly, raise and lower the lift and stop at different levels to get a good perspective on the lift's operations and movements.

SECTION 4

OPERATION

A. METHOD OF INSTRUCTIONS:

All XL, X3W or X4W Scissor Lifts are provided with a special relief valve and are factory preset for the maximum safe capacity of the lift. Activating and holding the up switch will energize the motor. The motor is attached to a positive displacement pump, that draws hydraulic fluid from the reservoir and transfers it under pressure to the cylinder. This forces the piston forward and the scissor legs to separate and raise the platform, releasing the up button will stop the lift. A check valve between the pump and piston holds the table in position. Depressing and holding the down switch will energize a solenoid, that allows the oil from the cylinder to return to the reservoir through a preset flow control.

This allows the lift to lower smoothly and at a controlled speed.

B. OPERATING INSTRUCTIONS:

In order to operate the lift follow these operating procedures.

Read and understand all the instructions before operating. If the lift has modifications or accessories, read and understand their functions.

- 1). Load the lift correctly.
 - a). Do not load the lift while it is running.
 - b). Do not exceed the maximum rated load (note that load capacity is reduced due to side or end loading.)
 - c). Place load in the center of table.
 - d). If the load is unstable or may become unstable, fasten it into position.
- 2). Operate the lift.
 - a). To raise the lift, press and hold the up button.
 - b). To lower the lift, press and hold the down button.
 - c). Release the button to stop the lift.
- 3). Wait until the lift has come to a complete stop before unloading the lift.
- 4). Stand clear of lift when operating it in order to avoid injury.

WARNING!

- a). **Do not stand, sit or climb onto the lift.**
- b). **Do not load or unload a moving lift.**
- c). **If the lift fails to move or exhibits strange movements or sound, stop immediately. Do not operate the lift until it has been checked and repaired.**
- d). **Obey all warning labels.**

SECTION 5

MAINTENANCE

Generally, the XL, X3W or X4W Series Scissor Lifts require very little maintenance. Reasonable care will result in excellent trouble-free performance.

WARNING!

Never go under or service lift with a load on the table or with the scissor mechanism unblocked. Always service the lift in a down position.

A. ROUTINE MAINTENANCE:

All routine maintenance should be performed monthly and can be performed on the standard XL, X3W or X4W Series Scissor Lifts in a lowered height position. Before performing any maintenance, shut the power off. Then raise the top over its center position, secure in place and perform the routine listed (1 through 7).

For lifts with oversized or beveled edge platforms, the lift must be serviced in an up position. The following procedure must be followed prior to servicing:

- a). Raise the lift to the full up position.
- b). Place the safety chock in position as shown in Figure 1.
- c). Lower the lift until the wheels come in contact with the chock.
- d). Shut the power off.
- e). Perform the routine listed (1 through 7).

WARNING!

Wood blocks should be cut to the proper length and be of a hard wood variety such as oak or ash. Check for defects or damage to the blocks prior to each usage. These blocks are to be used only if the maintenance chock has been damaged or misplaced.

- 1). Check oil level. Add oil if necessary.
- 2). Check rollers for signs of wear. Replace if damaged.
- 3). Check snap ring and shield. Replace if damaged.
- 4). Check hydraulic lines for damage or leaking. Replace if damaged.
- 5). Check for oil spots on the floor. Trace leaks to the proper fitting and tighten.
- 6). Check wiring for damage. Replace immediately if any sign of wear is evident.
- 7). Bearings on these lifts are permanently lubricated and require no servicing. Look for any signs of wear.

- 8). Check that all pre-cautionary labeling is in place and legible. Replace damaged labels immediately. See Figure 9.

B. TROUBLESHOOTING MAINTENANCE:

LIFT WILL NOT MOVE

1. No operational noises:
 - a). Check power switch, fuses and overloads.
 - b). Check voltage at motor -- motor may have failed.
2. Operational noises:
 - a). Lift may be overloaded or jammed. Check load weight and obstructions.
 - b). Motor (3 phase) single phasing. Check voltage at motor terminals.
 - c). Motor (3 phase) reversed. Reverse 2 lines.
 - d). Motor (1 phase) low voltage. Check voltage at motor terminal.
 - e). Oil shortage -- reservoir low or oil line failure. Repair or replace.
 - f). Down valve open, check wiring, remove and run lift.
3. Motor overheats:
 - a). Excessive cycle rate (15 per hour max.).
 - b). Low voltage -- check voltage at motor.
 - c). Oil starvation -- check filter in reservoir.

LIFT OPERATING SLOWLY

1. Up cycle:
 - a). Oil starvation -- check filter in reservoir.
 - b). Oil viscosity -- oil is too heavy or too thin.
 - c). Air in cylinder -- cycle lift with no load 2 times and hold down button for 20 seconds after bottoming out on each cycle.
2. Down cycle:
 - a). Down valve dirty -- remove and clean. Check oil condition, replace if dirty.
 - b). Pinched hydraulic lines.
 - c). Oil viscosity is too heavy.
3. Lift raises, then slowly lowers without power:
 - a). Down valve dirty. Remove and clean.
 - b). Leaking hydraulic lines or fittings (check for telltale oil spots).
 - c). Check valve in pump -- may not be seating. Requires new pump.
4. Lift will not lower when energized:
 - a). Down solenoid faulty. Check voltage -- may be low or wrong voltage for coil. Check continuity of coil (burned out).

SECTION 6

SERVICE

A. REPLACING CYLINDER SEALS:

(Seal kits are listed on page 9)

1. Lower the lift to its lowest position and hold down switch for an additional 10 to 20 seconds. Then lift the top to its over center position and secure.
2. For lifts with oversized platforms, the cylinder is replaced while the lift is in an up position. To position lift in the up position, follow instructions for routine maintenance (5A a-e).
3. Disconnect the electrical power.
4. Disconnect the hydraulic hose from the cylinder and cap the line to prevent hydraulic fluid loss.
5. Loosen the set screws holding the cylinder pin.
6. Remove the cylinder pin.
7. Lift the cylinder out of the lift.

CAUTION!

Hold the cylinder securely while removing the pin to prevent it from falling to the floor.

8. Clamp cylinder securely at the base end.
9. Completely collapse cylinder piston.
10. Push gland into the cylinder 1/8"- 3/16".
11. Remove retaining ring.
12. Remove piston rod, piston and gland from cylinder.
13. Remove rod nut, piston and gland.
14. Remove and replace seals and wipers.
15. Assemble piston and gland to piston rod.
16. Assemble rod nut to piston rod and torque to 100 ft./lb.
17. Lubricate piston and seals and install cylinder.
18. Insert retainer ring.
19. Install cylinder and hydraulic lines.
20. Fill reservoir.
21. a). For the lifts serviced in lowered position, lower tabletop completely.
b). For the lifts serviced in the up position, raise table and remove chocks.
22. Cycle lift 2-3 times adding oil if necessary.
23. Recheck reservoir oil level.

A. REPLACING LEG ROLLERS

(Seal kits are listed on page 9)

1. a). For standard lifts, lower lift to its lowest position and hold down switch for an additional 10-20 seconds. Then lift the top to its over center position and secure.
b). For lifts with oversize or beveled platform secure the lift as follows: Raise the lift to its full raised position. Place a steel 7/8" or 1" bar through both outer scissor leg holes. Lower the lift until the inner legs are firmly in contact with the bar.
2. Disconnect electrical power.
3. Raise the leg assembly 2" and support with the yellow supplied safety chock.
4. Remove retainer clips, shield and rollers.
5. Clean and lubricate axle. Replace with new rollers, shields and clips.
6. a). For lifts serviced in a lowered position lower the tabletop completely.
b). For lifts serviced in the up position, raise table slightly and remove steel bars.

SECTION 6

TROUBLESHOOTING

IF LIFT DOES NOT RISE TO FULL HEIGHT — check for leaks or shortage of oil. Maintain the proper oil level. To check oil level, follow these instructions:

- ? On left hand side, on top of oil well, you will find a hexagon cap screw which is also a dipstick.
? Remove the cap screw and fill oil well with hydraulic oil. Oil should reach notch on dipstick.

IF THE LIFT TENDS TO CREEP DOWNWARD UNDER A LOAD — a speck of dirt may be obstructing the seating of the valve and allowing leakage. To correct, follow these instructions:

- ? Raise lift to full lifting height and then lower it to lowest point of lift. It may be necessary to do this five or six times. In lowering the lift, lower it in stages, that is, lower the lift six inches to a foot at a time. This will dislodge the dirt and lift will operate properly.

**FIGURE 1:
MAINTENANCE CHOCK**

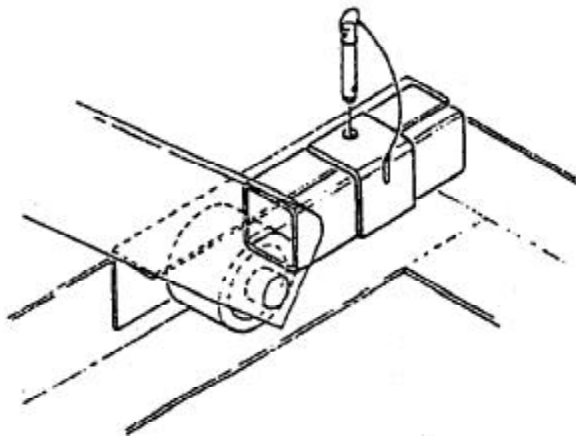

XL SERIES PRODUCT ILLUSTRATIONS

COMPONENT IDENTIFICATION		
ITEM NO.	PART NUMBER	DESCRIPTION
1	E307	Pushbutton
1	E308-E36	Foot control with Cover (12 ft. cord)
2	1000-176	Down Solenoid
3	1000-034-10	Hydraulic Pump Assembly (1 gallon/min.)
4	E255R	Electric Motor (115/1/60)
5	1000-067	Roller Assembly Kit
6	See Page 10	Hydraulic Line
7	See Page 13	Reservoir -- Oil Tank
8	EX281	Electrical Box -- Nema 12 (115V Only)
9	N1220	Reservoir Fill cap
10	1000-067	Roller Assembly Kit
11	See Page 12	Cylinder
12	N1215	Cylinder Breather Cap (KL 24 only)
13	See Page 12	Maintenance Chock
14	1000-176	Valve Stem
15	1000-056-01	115V Coil
16	1000-056-02	24V Coil

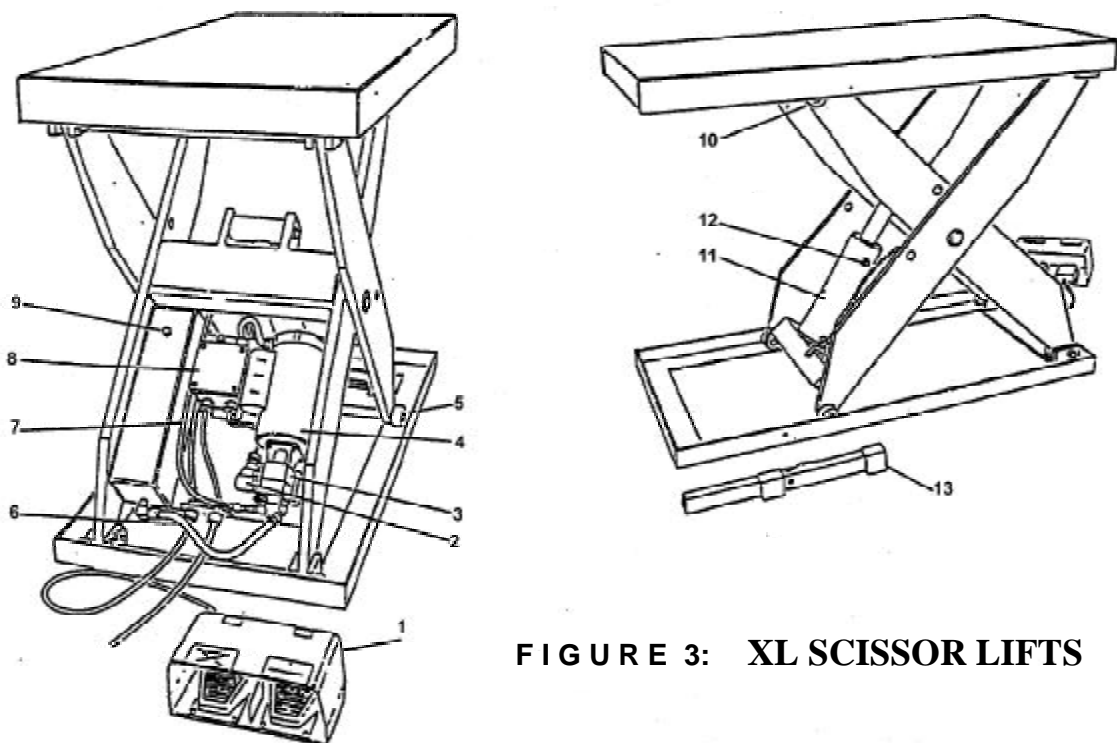

FIGURE 3: XL SCISSOR LIFTS

X3W and X4W PRODUCT ILLUSTRATIONS

FIGURE 4 -- EXPOSED CYLINDER ASSEMBLY

ITEM NO.	PART NUMBER	DESCRIPTION
1	See Page 12	Hydraulic Cylinder
2	1000-086	Safety Velocity Fuse
3	1000-067	Roller Kit Assembly
4	See Page 12	Maintenance Chock

FIGURE 5 -- EXPOSED POWERPACK

ITEM NO.	PART NUMBER	DESCRIPTION
1	E255R	Motor (115/1/60)
2	1000-034-10	Hydraulic Pump Assembly (1 gallon/min.)
3	See Page 13	Reservoir -- Oil Tank
4	N1220	Reservoir Fill Plug
5	EX281	Electric Box (115V only)

**FIGURE 4:
EXPOSED CYLINDER ASSEMBLY**

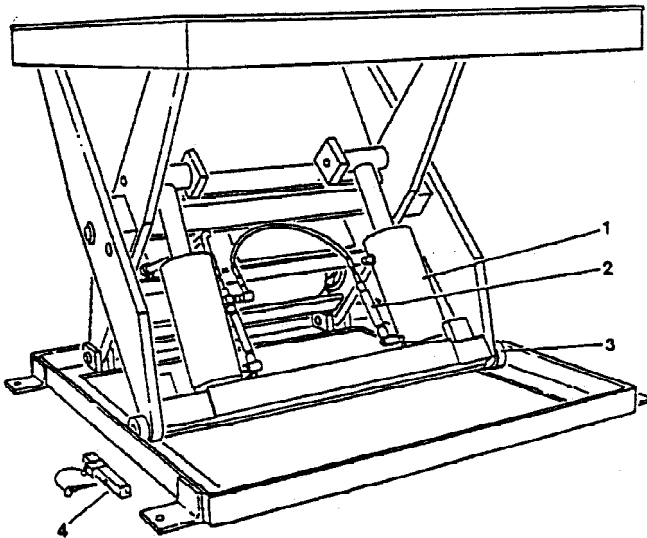

**FIGURE 5:
EXPOSED POWERPACK**

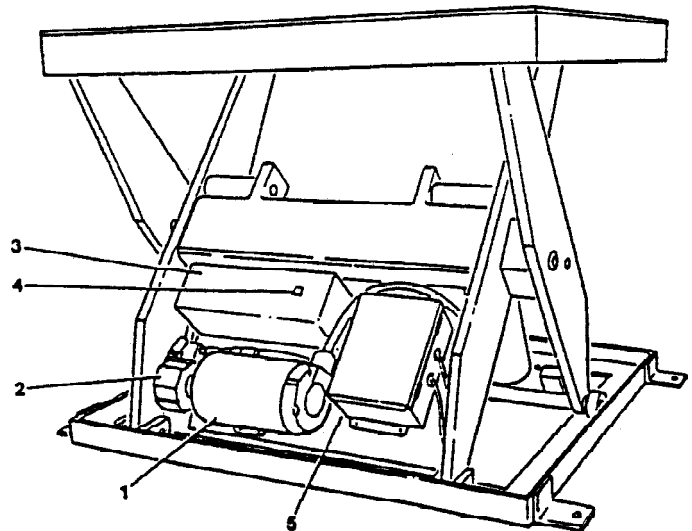

RECOMMENDED SPARE PARTS LISTING

DESCRIPTION	PART #	USED ON: MODEL
Foot Switch	E308-E36	All Units
Down Solenoid	1000-056-01	115 VAC Phase Power Lift, Coil Only
	1000-056-02	208, 220, 460, 1 & 3 Phase Power Lift, 24V Coil Only
	1000-176	Valve Stem Only
Pump	1000-034-10	1 GPM. All 24" Travel Series. All 36" Travel Series with 2000, 3000 and 4000 Capacities
	1000-034-20	2 GPM. All 36" Travel Series with 5000 and 6000 Capacities. All 48" Travel Series.
Motor	E225R	1HP 1PH. All 24" Travel Series. All 36" Travel Series with 2000, 3000 and 4000 Capacities.
	E255T	1.5 HP 3PH. All 36" Travel Series with 5000 and 6000 Capacities. All 48" Travel Series.
Roller Kit	1000-067	All Units
Hose Hydraulic High Pressure	Contact Presto Parts	XL24 Series, X3W24 Series, X4W24 Series
Hose Hydraulic Low Pressure	80000006VR	All Units
Junction Box	EX 281	All Units (15V only)
Reservoir Fill Plug	N1220	All Units
Cylinder	1000-018 (3-1/2")	All 36" travel lifts with 2000, 4000 and 6000 capacity (not XT36-40)
	1000-019 (3-1/2")	XL36-40 Only
	1000-020 (4")	XL24-40 Only
	1000-021 (3-1/2")	All 24" travel lifts with 2000, 4000 and 6000 capacity (not XL24-40)
	1000-023 (3-1/2")	All 48" travel lifts with 2000, 4000 and 6000 capacity
Cylinder Vent Plug	N1215	All Units
Maintenance Chock	1000-234-01VR	XL24 Series, X3W24 Series, X4W24 Series
Flow Control Valve	B211RC-A	All Units
Hydraulic Safety Fuse	1000-086	All Units
Cylinder Seal Kit	1000-059-01	For All 3-1/2" Diameter Cylinders.
	1000-059-02	For All 4" Diameter Cylinders

Pendant	E307	NEMA 1 - 115 Volt AC 25 AMP
Transformer	E306	All Units
Contactor	E305-115	All equipment with 115 Volt Secondary Control Voltage
	E305-24	All equipment with 24 Volt Secondary Control Voltage
Reservoir	1000-196-01VR	All 36" Travel Units
	1000-196-02VR	All 48" Travel Units
	1022-025VR	All 24" Travel Units
Reservoir Filter	1000-046	All Units

All part orders must be received via fax or USPS.

The model number and serial number must be provided to ensure proper installation and operation.

FIGURE 6: WIRING SCHEMATIC 115/1/60 power with 20 AMP PLUG

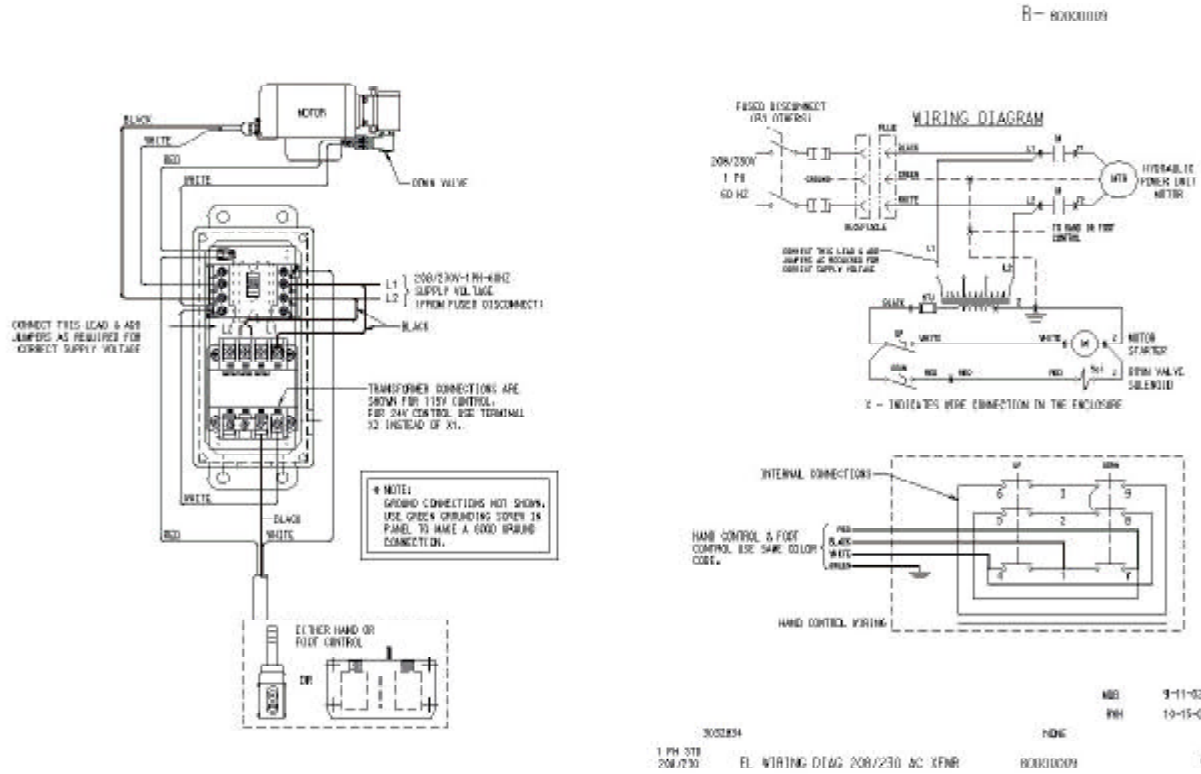

FIGURE 7: WIRING SCHEMATIC 208, 220, 460/3/60 POWER with PIG TAIL

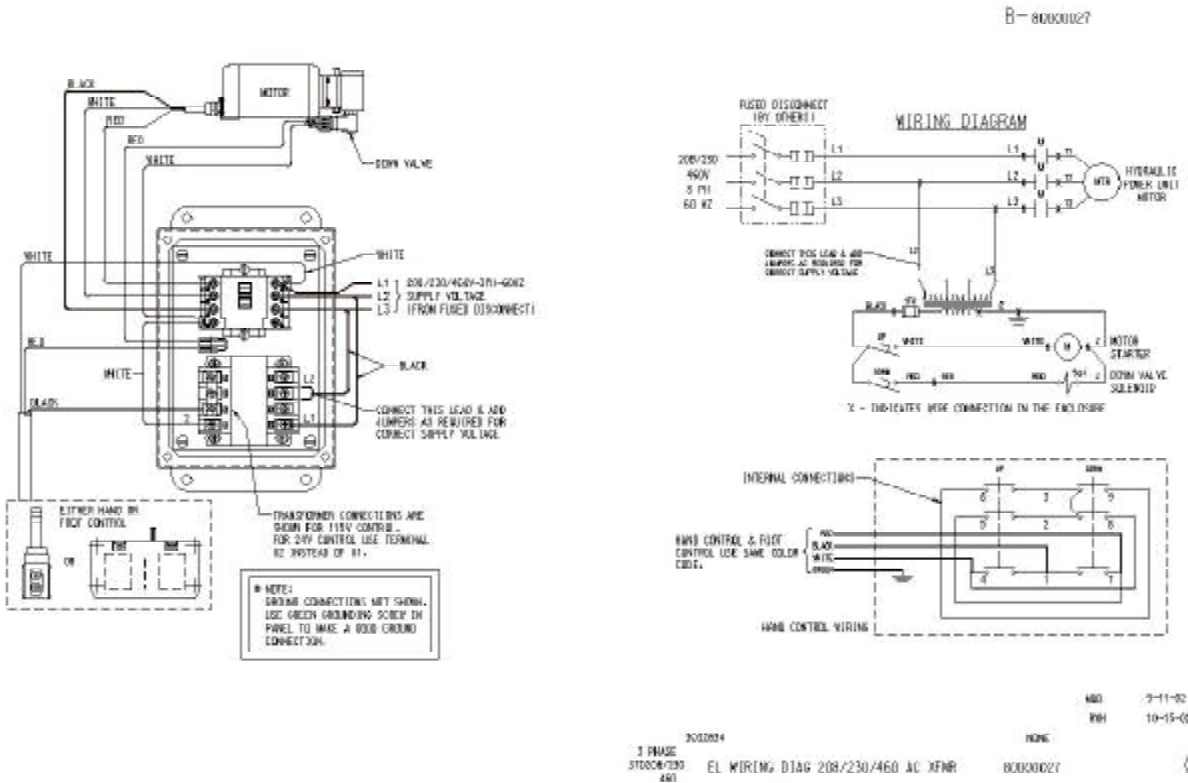
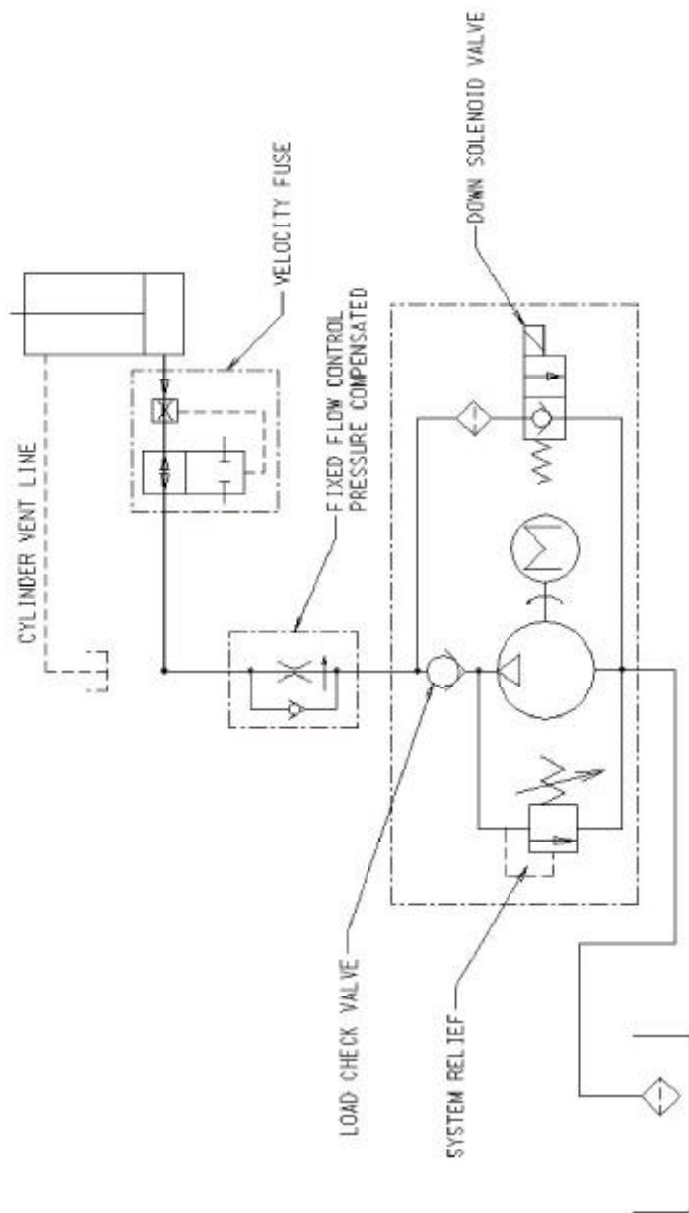

FIGURE 8: HYDRAULIC SCHEMATIC for all MODELS

A- 80000010



SMS 9-20-02
RWH 10-16-02

3007039

HY PLUMBING SCHEMATIC 80000010
STD LIFT WITH 1 CYLINDER & VELOCITY FUSE

RESTOCKING POLICY

Presto Lift, Inc.'s goal is for you to be satisfied with your order. Merchandise may be returned, but returns will be subject to a restocking fee to cover the costs Presto Lift, Inc. incurs which include but are not limited to handling, storage of the units, etc. Presto Lift, Inc. will issue refurbishing costs where end-user wear is apparent. We would prefer to not charge for these costs but find it necessary any apologize for any inconvenience. Please review the RETURN MATERIALS AUTHORIZATION (RMA) PROCEDURES.

LIFTS

Lifts may be returned with a restocking fee according to the following schedule:

1. Standard unit or standard unit with stock options:

Five or less	20%
With re-order	15%
Six (6) or more of the same model	30%
With re-order	20%
2. Custom engineered/modified lifts: No Returns

PARTS

Standard parts may be returned with a 20% restocking fee or \$35.00 net, whichever is greater. Modified or custom-engineered parts are not returnable. Unfortunately, due to potentially concealed damage, all sales of electrical assemblies are final.

QUALITY ISSUES

Should you feel there is a quality problem, please contact the seller to ask questions and gather information on how to rectify the issue. Presto Lift Inc. reserves the right to determine potential credits, as a result of factory defects, based on its inspection of the merchandise.

GENERAL

All products shipped from our factory have passed Quality Assurance inspection and testing. The carrier of choice has signed for, and accepted the product in new working condition. The customer should inspect to ensure it is not received damaged, has no concealed damage or is not incomplete. Parts orders are determined to be complete based upon Presto Lift, Inc. inspection sheets and carrier shipping weights.

RETURN MATERIALS AUTHORIZATION (RMA) PROCEDURES

Although Presto Lift, Inc. is not legally obligated to issue a credit for any merchandise, the RETURN MATERIALS AUTHORIZATION (RMA) PROCEDURE is provided as a courtesy to our customers in the event they do not receive what they wanted.

If a customer wishes to return a Presto Lift, Inc. product, the first step in the process is to request an RMA number from Presto Lift, Inc.'s Customer Service Department. This request must be made on or before the thirtieth (30th) calendar day following the date of Presto Lift, Inc.'s invoice for the merchandise being returned.

The RMA number must appear on the outside of any packaging material for a return to be accepted and processed by Presto Lift, Inc. Customers shipping returns back to Presto Lift, Inc. from the Continental US, Canada and Mexico have fourteen (14) days from the effective date of the RMA to have the merchandise arrive freight prepaid at Presto Lift, Inc. Returns from locations other than the Continental US, Canada and Mexico must be shipped within the fourteen (14) day period to arrive Free On Board (FOB) at Presto Lift Inc as soon as practical. If a customer believes Presto Lift, Inc.'s merchandise is defective, freight will be reimbursed to the original "Bill To" on the invoice if Presto Lift Inc. finds that the merchandise is defective.

Please remember that merchandise with RMA's coming back to Presto Lift Inc. from the Continental US, Canada and Mexico will not be accepted by Presto Lift Inc. if the returned goods do not arrive freight prepaid at Presto Lift Inc. within the fourteen (14) day effective period.

All credits issued are less restocking fees as applicable, plus any assessed outbound/inbound in-transit damages.

Return addresses: please refer to your RMA for the address to which your product should be returned.

Presto Lift Inc.
21 Park Street
Attleboro, MA 02703

Telephone: 800-343-9322
Fax: 888-788-6496

Ordering Replacement Parts

Presto Lifts has carefully chosen the components in your unit to be the best available for the purpose. Replacement parts should be identical to the original equipment. Presto Lifts will not be responsible for equipment failures resulting from the use of incorrect replacement parts or from unauthorized modifications to the unit.

Presto Lifts can supply all replacement parts for your lift. With your order, please include the model number and the serial number of the unit. You can find these numbers on the name plate. This plate is located within the scissors mechanism.

To order replacement parts, please call the Presto Parts Department. Parts are shipped subject to the following terms:

- FOB factory
- Returns only with the approval of our parts department.
- Credit cards preferred (except parts covered by warranty).
- Freight collect for truck (except parts covered by warranty).
- Freight – prepaid and invoice for small parcel shipments (except parts covered by warranty).

Parts replaced under warranty are on a “charge-credit” basis. We will invoice you when we ship the replacement part, then credit you when you return the worn or damaged part.

Presto Parts Department

21 Park Street
Attleboro, MA 02703

Telephone: 800-343-9322

FAX: 888-788-6496

Email: service@PrestoLifts.com

www.PrestoLifts.com

Maintenance

Routine Periodic Maintenance

Every 90 days -

- Apply grease or heavy oil to the pivot shafts.
- Check for loose hardware and signs of excessive wear or binding.
- Check to be sure that the unit is placed on a firm level surface.

If the optional adjustable feet are installed, be sure that all four feet are touching the floor and are locked in position.

NOTES:

Presto Lifts Limited Warranty Policy

Presto Lifts warrants all of its products against defects in the welded structural frame and, if applicable, scissor legs from faulty material and workmanship for a period of five (5) years from the date of invoice.

A lifetime limited warranty is provided for the Airstroke Actuator™ in all pneumatic lifts against any defect due to faulty material or workmanship.

All batteries are covered under a separate limited warranty from the battery manufacturer for a period of one year from the date of invoice.

All other components have a limited warranty against defects in faulty material and workmanship for a two (2) year period from the date of invoice date of invoice and 30 day limited warranty on labor. Please note that prior authorization from Presto Lifts is required on all warranty work.

There are no implied warranties of any kind, more specifically, there are no warranties of merchantability or fitness for any particular purpose. Presto Lifts' sole warranty shall be as set forth in this limited warranty.

Presto Lifts will elect to repair or replace a defective component without charge, if any components should become defective within the limited warranty period. Proof of purchase is required for warranty. The charge for shipping the defective component is the responsibility of the buyer and must be accompanied with an RMA number. The shipping charge to return the component to the buyer is the responsibility of Presto Lifts, Inc.

This limited warranty does not cover labor expense for removal or reinstallation of components after thirty days. This limited warranty shall not cover, among other things: damages resulting from foreign matter or water, failure to provide reasonable and necessary maintenance, and if applicable, use of product while charger is plugged into an AC outlet, or failure to follow operating instructions. The limited warranty is not valid for damage resulting from negligence, accident, unreasonable use, abuse or misuse, exceeding data plate capacities or altering the product without Presto Lifts authorization.

Presto Lifts expressly disclaims and excludes any liability for consequential, incidental, indirect or punitive damages or financial loss to people or property resulting from any breach of warranty or the operation or failure of this product.

Presto Lifts makes no representation that this product complies with local, state, or federal safety/product standards codes. Should this product fail to comply in any way with those codes, it shall not be considered a defect of materials or workmanship. Presto Lifts shall not be held liable for any damages resulting from noncompliance. It is the dealer's responsibility to exercise this limited warranty. This limited warranty is provided to the original purchaser (defined as the original end user) and is nontransferable. This constitutes the complete and final agreement involving Presto Lifts and limited warranty obligations for products.