

## Model TA Horizontal Belt Conveyor

A very versatile conveyor, the Model TA can be used in many types of material handling situations such as assembly line operations, sorting, packing, and inspection. Conveyor sets up quickly and easily to save on installation time.

- 10 Belt Widths
- Reversible (with center drive)
- Smooth, Slim Bed
- Adjustable MS-Type Floor Supports Available



Conveyor shown with optional floor supports



SLIDER BED

SIZE TO ORDER Overall Length "A"	Bed Length "L"	Overall Length with Center Drive	Drive Pulley	Belt Width	6"	8"	10"	12"	14"	16"	18"	20"	24"	30"
				Bed Width	10"	12"	14"	16"	18"	20"	22"	24"	28"	34"
6'	5'	6'	4" Dia.	WEIGHTS (Lbs.)	239	252	262	272	282	305	315	343	366	389
11'	10'	11'			271	286	300	314	328	368	382	397	422	447
16'	15'	16'			324	343	362	380	398	456	475	494	528	562
21'	20'	21'			354	377	400	422	444	519	542	565	607	649
26'	25'	26'			406	434	461	488	514	607	635	662	713	764
31'	30'	31'			436	468	499	530	560	670	702	733	792	851
36'	35'	36'			488	525	560	596	630	758	795	830	898	966
41'	40'	41'			519	559	599	638	677	821	862	901	977	1053
46'	45'	46'			570	616	660	704	747	909	955	998	1083	1168
51'	50'	51'			605	655	704	753	801	982	1032	1081	1176	1271
56'-11"	55'	56'	8" Dia.	WEIGHTS (Lbs.)	652	712	795	819	871	1070	1125	1178	1282	1386
61'-11"	60'	61'			688	746	804	861	918	1133	1192	1249	1351	1453
66'-11"	65'	66'			734	803	865	927	988	1221	1285	1346	1457	1568
71'-11"	70'	71'			772	839	905	971	1036	1287	1364	1420	1549	1678
76'-11"	75'	76'			816	896	966	1037	1106	1375	1457	1517	1655	1793
81'-11"	80'	81'			855	930	1005	1079	1153	1438	1514	1588	1734	1880
86'-11"	85'	86'			898	987	1066	1145	1223	1526	1607	1685	1840	1995
91'-11"	90'	91'			937	1021	1104	1187	1269	1589	1673	1756	1920	2084
96'-11"	95'	96'			980	1078	1165	1253	1339	1677	1766	1853	2026	2199
101'-11"	100'	101'			1020	1112	1204	1295	1386	1740	1833	1924	2105	2286

All weights in catalog are CONVEYOR WEIGHTS ONLY. Accessories, crating, etc., are not included.

NOTE: All Standard Widths to be Offered in 1 ft. Length Increments - 1 Week Stockyard except 34 in. OAW.

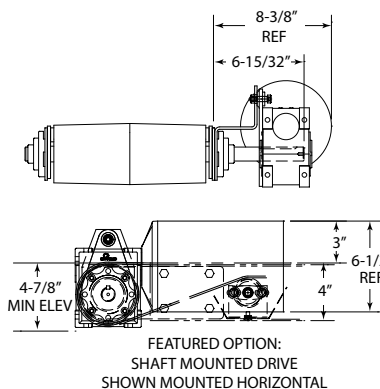
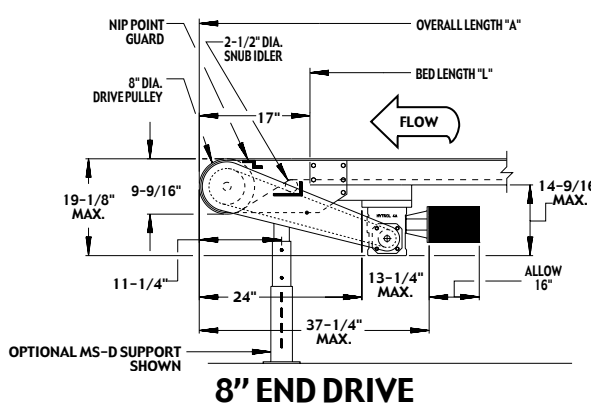
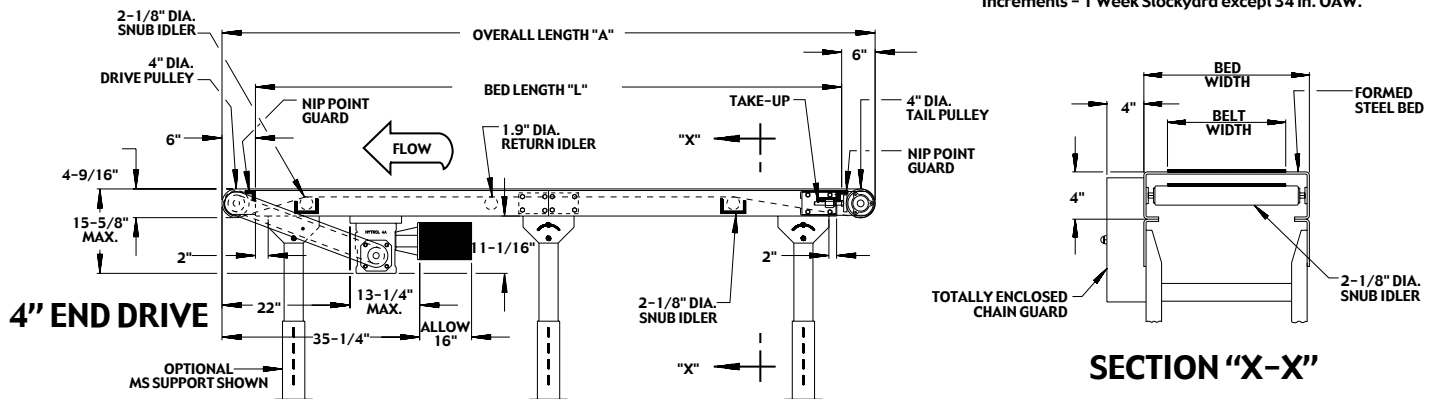

SPEED FPM	MAX HP
34	1/2
41	1/2
52	1/2
68	1
82	1
103	1
138	1
206	1
274	1
412	1



Conveyor shown with featured option - shaft mounted end drive



# • Standard Specifications

**BELT**–Ultimate 140 BBS–Nitrile.

**BED**–4 in. deep x 12 ga. formed steel slider bed– powder painted. Standard 5 ft. & 10 ft. long sections bolt together with splice plates.

**END DRIVE**–Located on discharge end of conveyor, chain guard on left hand side.

**DRIVE PULLEY**–4 in. dia. with 1 in. dia. shaft at bearings or 8 in. dia. with 1–3/16 in. dia. shaft at bearings, machine crowned and fully lagged. See chart.

**TAIL PULLEY**–4 in. dia. with 1 in. dia. shaft at bearings, machine crowned.

**SNUB IDLER**–Adjustable 2–1/8 in. dia. for 4 in. pulley–2–1/2 in. dia. for 8 in. pulley. Pre-lubricated ball bearings. Guards included.

**RETURN IDLER**–Adjustable 1.9 in. dia. pre-lubricated ball bearings.

**TAKE-UP**–Take-ups at tail pulley. Provides 4 in. of belt take-up.

**BEARINGS**–Sealed, pre-lubricated, self-aligning, ball bearings on drive and tail pulleys.

**SPEED REDUCTION**–Sealed worm gear C-Face speed reducer. No. 50 roller chain to drive pulley.

**MOTOR**–1/2 HP–208/230/460V/575–3 Ph.–60 Hz. Totally Enclosed C-Face.

**BELT SPEED**–Constant 65 FPM.

**CAPACITY**–Maximum load per linear foot of conveyor 75 lbs. NOT TO EXCEED capacity in charts.

**FLOOR SUPPORTS**–Now supplied as optional equipment.

LOAD CAPACITY CHART @ 65 FPM W/STANDARD BELT								
HP	BELT WIDTHS TO	LENGTHS UP TO						
		4" Dia. Drive Pulley				8" Dia. Drive Pulley		
		11'	21'	31'	41'	51'	77'	102'
DISTRIBUTED LOAD (LBS.)								
1/2	6"–16"	335	320	310	300	285	260	230
	18"–28"	320	300	285	270	255	210	170
1	6"–16"	650	635	625	615	605	625	595
	18"–30"	635	620	600	585	570	580	540

LOAD CAPACITY CHART 25° INCLINE @ 65 FPM W/ROUGHTOP BELT						
HP	BELT WIDTHS TO	LENGTHS UP TO				
		11'	21'	31'	41'	51'
		DISTRIBUTED LOAD (LBS.)				
1/2	6"–16"	155	145	135	125	110
	18"–28"	145	130	115	100	80
1	6"–16"	310	300	290	280	270
	18"–30"	305	285	270	255	240

## • Optional Equipment

**FLOOR SUPPORTS**–MS Type floor supports are available with a wide range of adjustment. Specify top of belt or roller elevation. One support required at every bed joint and ends of conveyor. Holes in feet for lagging to floor. Knee braces recommended above MS–6 support.

**BELT\***–White Polymate 100 RMP–COS (cover one side), Black Trackmate 120 Roughtop with PVC cover, Brown Polymate Roughtop w/Nitrile cover, Black Trackmate 533 COS–PVC, Tan Glidetop, Pure Gum Rubber Roughtop.

**BELT SPEED\***–Other constant and variable speeds. V-belt drive supplied under 17 FPM.

**SHAFT MOUNTED END DRIVE**–Motor reducer unit mounted on extended drive pulley shaft. Can be mounted with motor horizontal for 4–7/8 in. minimum elevation. Mounting bracket and torque arm allows for multiple mounting positions. 4 in. drive only. See chart page 5 for speeds.

**OVERHEAD END DRIVE**–Motor–reducer unit mounted 9–1/2 in. above belt. Other clearances available, specify. (Chain guard right hand side). Minimum elevation 6 in. with 4 in. drive, 10 in. with 8 in. drive.

**SIDE MOUNTED END DRIVE**–Motor–reducer unit mounted on left hand side of conveyor. Minimum elevation 7 in. with 4 in. drive, 10 in. with 8 in. drive.

**CENTER DRIVE**–Provides 16 in. of belt take-up. Minimum elevation 16 in. with 4 in. drive, 17 in. with 8 in. drive. Specify location. Minimum OAL without modification–63 in. with 4 in. drive, 66 in. with 8 in. drive

**LOW ELEVATION SIDE MOUNTED CENTER DRIVE**–Motor–reducer unit mounted to side of conveyor. Minimum elevation 13–1/2 in. with 4 in. or 8 in. drive.

**STACKED END DRIVE**–Minimum elevation 27–3/4" with V-belt drive, 33–3/4" with C-Face drive.

**V-BELT DRIVE**–V-Belt supplied between motor and reducer. Minimum overall drive width 14 in. Allow 65 in.

**O-RING DRIVE CHAIN**–With sealed in lubricant (Recommended for applications that do not permit regular lubrication).

**UNDERSIDE TAKE-UP**–Provides 16 in. of belt take-up. Extends down 13–1/8 in. from top of belt.

**SIDE TABLES**–Powder painted 14 ga. formed steel table, 10 in., 16 in., or 22 in. wide from side of bed. One or both sides.

**GUARD RAILS**–Universal adjustable universal channel, solid side guards, PC side guards with formed top. Fixed Channel overlapping, one direction (use with systems ends only). Fixed Channel non-overlapping, reversing (use with system ends only).

**NOSEOVER\***–Adjustable, single (0° to 15°), double (0° to 30°).

**LOWER POWERED FEEDER\***–Chain type driven from tail pulley of inclined conveyor. Underside take-up required when end drive is used. MS-Type floor supports now supplied as optional equipment. 8 in. dia. drive recommended on conveyor when feeder exceeds 44–1/2 in. OAL–50–1/2 in. OAL with system end.

**GRAVITY BRACKETS**–Adjustable bars with 1 in. dia. pop-out transfer roller to attach wheel or 1–3/8 in. roller conveyor. Available 12 in. to 28 in. bed widths only.

**BUTT COUPLINGS**–Provides connection to SB, RB, LR, ACC, ACZ, ABEZ, 190–NSP, 190–NSPEZ, 1.9 in. & 2.0 in. gravity conveyors. Includes 1 in. dia. pop-out roller. Center drive or underside take-up recommended.

**SYSTEM END ROLLER**–12 in. long tail sections provide connection to SB, RB, LR, ACC, ACZ, ABEZ, 190–NSP, 190–NSPEZ, 1.9 in. & 2.0 in. gravity conveyors. Includes 1.9 in. dia. pop-out transfer roller. Belt width is 6 in. less than bed width. (Center drive or underside take-up required.) Not available on 10 in. bed.

**PULLEYS**–6 in. tail with 1–3/16 in. dia. shaft at bearings, or 8 in. drive with 1–3/16 in. dia. shaft at bearings.

**CASTERS**–See Accessory section.

**POLY-TIER SUPPORTS**–36 in. to 120 in. support heights in 6 in. increments. Knee braces supplied.

**CEILING HANGERS**–5/8 in. dia. x 8 ft. long unplated rods fully threaded. Other lengths and galvanized rods available.

**MOTORS**–Energy efficient, single phase, brakemotor, other characteristics. 2 HP maximum.

**ELECTRICAL CONTROLS**–One direction manual start switch, reverse drum switch, non-reversing and reversible magnetic starters, push button stations. AC variable frequency drive.

\* NOTE: Capacity affected with these options.

