

# HYTROL CONVEYOR COMPANY, INC.

## Model **TR** Horizontal Belt Conveyor (Troughed Bed)



Conveyor shown with optional floor supports

The Model TR, with built-in guard rails, is ideal for overhead conveying applications. It easily conveys boxes, cartons, cases, bags, etc., as well as loose parts.

- 10 Belt Widths
- Reversible (with center drive)
- Troughed Bed
- Adjustable MS-Type Floor Supports Available



SIZE TO ORDER Overall Length "A"	Bed Length "L"	Overall Length with Center Drive	Drive Pulley	Black Friction Surface Belt Widths									
				6"	8"	10"	12"	14"	16"	18"	20"	24"	30"
				Between Side Guards									
				7"	9"	11"	13"	15"	17"	19"	21"	25"	31"
Overall Bed Widths													
				8"	10"	12"	14"	16"	18"	20"	22"	26"	32"
6'	5'	6'	4" Dia.	254	267	277	287	297	320	330	358	381	404
11'	10'	11'		301	316	330	344	358	398	412	427	452	477
16'	15'	16'		369	388	407	425	443	501	520	539	573	607
21'	20'	21'		422	445	468	490	512	535	558	581	627	696
26'	25'	26'		491	519	546	573	599	627	655	683	739	823
31'	30'	31'		538	570	601	632	662	694	726	758	822	918
36'	35'	36'		535	621	656	694	737	773	810	846	919	1029
41'	40'	41'		655	695	735	759	813	853	894	935	1017	1140
46'	45'	46'		702	747	760	836	892	932	978	1023	1114	1249
51'	50'	51'		775	825	874	923	971	1022	1072	1122	1222	1372
56'-4"	55'	56'	8" Dia.	822	876	929	985	1046	1101	1156	1210	1319	1481
61'-4"	60'	61'		892	950	1008	1065	1122	1181	1240	1299	1417	1594
66'-4"	65'	66'		939	1001	1063	1127	1197	1260	1324	1387	1514	1703
71'-4"	70'	71'		1013	1081	1148	1215	1281	1351	1419	1487	1623	1827
76'-4"	75'	76'		1060	1132	1203	1277	1356	1430	1503	1575	1720	1936
81'-4"	80'	81'		1130	1206	1282	1357	1432	1521	1587	1664	1818	2049
86'-4"	85'	86'		1146	1257	1337	1419	1507	1589	1671	1752	1915	2158
91'-4"	90'	91'		1177	1331	1415	1499	1582	1669	1754	1839	2039	2324
96'-4"	95'	96'		1293	1382	1470	1561	1657	1748	1838	1927	2136	2433
101'-4"	100'	101'		1363	1456	1549	1641	1733	1828	1922	2016	2204	2486

NOTE: 16", 18" & 22" Bed Width (Up to 51' Length) - 1 Week Stockyard

SLIDER BED

All weights in catalog are CONVEYOR WEIGHTS ONLY. Accessories, crating, etc., are not included.

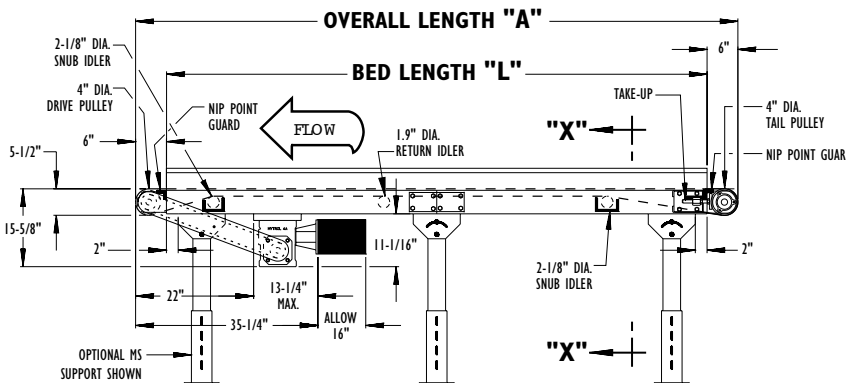

4" END DRIVE

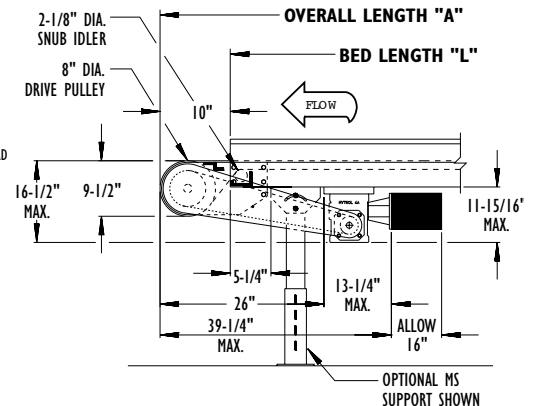

8" END DRIVE

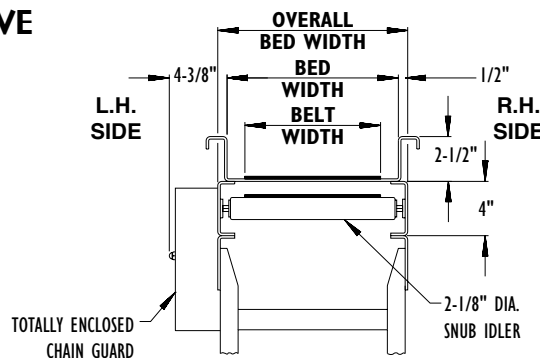

SECTION "X-X"



# • Standard Specifications

**BELT**–Ultimate 140 BBS–Nitrile.

**BED**–4 in. deep x 12 ga. formed steel slider bed with 2–1/2 in. deep guards, powder painted. Standard 5 ft. & 10 ft. long sections bolt together with splice plates.

**END DRIVE**–Located on discharge end of conveyor, chain guard on left hand side.

**DRIVE PULLEY**–4 in. dia. with 1 in. dia. shaft at bearings or 8 in. dia. with 1–3/16 in. dia. shaft at bearings, machine crowned and fully lagged. See chart.

**TAIL PULLEY**–4 in. dia. with 1 in. dia. shaft at bearings, machine crowned.

**SNUB IDLER**–Adjustable 2–1/8 in. dia. pre-lubricated ball bearings. Guards included.

**RETURN IDLER**–Adjustable 1.9 in. dia. pre-lubricated ball bearings.

**TAKE-UP**–Take-ups at tail pulley. Provides 4 in. of belt take-up.

**BEARINGS**–Sealed, pre-lubricated ball bearings, self-aligning, ball bearings on drive and tail pulleys.

**SPEED REDUCTION**–Sealed worm gear C-Face speed reducer. No. 50 roller chain to drive pulley.

**MOTOR**–1/2 HP–208/230/460/575V–3 Ph.–60 Hz. Totally Enclosed C-Face.

**BELT SPEED**–Constant 65 FPM.

**CAPACITY**–Maximum load per linear foot of conveyor 75 lbs. NOT TO EXCEED capacity in charts.

**FLOOR SUPPORTS**–Now supplied as optional equipment.

LOAD CAPACITY CHART @ 65 FPM W/STANDARD BELT								
HP	BELT WIDTHS TO	LENGTHS UP TO						
		4" Dia. Drive Pulley					8" Dia. Drive Pulley	
		11'	21'	31'	41'	51'	77'	102'
DISTRIBUTED LOAD (LBS.)								
1/2	16"	335	320	310	300	285	260	230
	24"	320	300	285	270	255	210	170
	30"	300	275	255	235	215	165	115
1	16"	650	635	625	615	605	625	595
	24"	635	620	600	585	570	580	540
	30"	620	595	575	550	530	535	480

LOAD CAPACITY CHART 25° INCLINED @ 65 FPM W/ROUGH TOP BELT						
HP	BELT WIDTHS TO	LENGTHS UP TO				
		11'	21'	31'	41'	51'
		DISTRIBUTED LOAD (LBS.)				
1/2	16"	155	145	135	125	110
	24"	145	130	115	100	80
	30"	135	115	95	75	55
1	16"	310	300	290	280	270
	24"	305	285	270	255	240
	30"	290	270	250	230	210

# • Optional Equipment

**FLOOR SUPPORTS**–MS Type floor supports are available with a wide range of adjustment. Specify top of belt or roller elevation. One support required at every bed joint and ends of conveyor. Holes in feet for lagging to floor. Knee braces recommended above MS–6 support.

**BELT\***–White Polymate 100 RMP–COS (cover one side), Black Trackmate 120 Roughtop with PVC cover, Brown Polymate Roughtop w/Nitrile cover, Black Trackmate 533 COS–PVC, Tan Glidetop, Brown Nitrile Roughtop.

**BELT SPEED\***–Other constant and variable speeds. V-belt drive supplied under 17 FPM.

**HIGHER SIDES**–4 in., 6 in., 9 in., and 12 in. high vertical sides (12 in. Maximum).

**OVERHEAD END DRIVE**–Motor reducer unit mounted 9–1/2 in. above belt. Other clearances available, specify. Chain guard RH side. Minimum elevation 6 in. with 4 in. drive, 10 in. with 8 in. drive.

**SIDE MOUNTED END DRIVE**–Motor reducer unit mounted to LH side of conveyor. Minimum elevation 7 in. with 4 in. drive, 10 in. with 8 in. drive.

**CENTER DRIVE**–Provides 16 in. of belt take-up. Minimum elevation 16 in. with 4 in. drive, 17 in. with 8 in. drive. Specify location. Minimum OAL without modification–63 in. with 4 in. drive, 66 in. with 8 in. drive.

**LOW ELEVATION SIDE MOUNTED CENTER DRIVE**–Motor–reducer unit mounted to side of conveyor. Minimum elevation 13–1/2 in. with 4 in. or 8 in. drive.

**STACKED END DRIVE**–Minimum elevation 27–3/4" with V-belt drive, 33–3/4" with C-Face drive.

**SHAFT MOUNTED END DRIVE**–Contact Factory

**V-BELT DRIVE**–V-Belt supplied between motor and reducer. Minimum overall drive width 14 in. Allow 65 in.

**O-RING DRIVE CHAIN**–With sealed in lubricant (Recommended for applications that do not permit regular lubrication).

**UNDERSIDE TAKE-UP**–Provides 16 in. of belt take-up. Extends down 13–1/4 in. from top of belt.

**NOSEOVER\***–Adjustable, single (0° to 15°), double (0° to 30°).

**LOWER POWERED FEEDER\***–Chain type driven from tail pulley of inclined conveyor. Underside take-up required when end drive is used. MS-Type floor supports now supplied as optional equipment. 8 in. dia. drive recommended on conveyor when feeder exceeds 44–1/2 in. OAL.

**GRAVITY BRACKETS**–Adjustable bars with 1 in. dia. pop-out transfer roller to attach wheel or 1–3/8 in. roller conveyor. Available 11 in. to 25 in. bed widths only.

**BUTT COUPLINGS**–Provides connection to SB, RB, LR, ACC, ACZ, ABEZ, 190–NSP, 190–NSPEZ, 1.9 in. & 2.0 in. gravity conveyors. Includes 1 in. dia. pop-out roller. Center drive or underside take-up recommended.

**PULLEYS**–6 in. tail with 1–3/16 in. dia. shaft at bearings or 8 in. drive with 1–3/16 in. dia. shaft at bearings.

**CASTERS**–See Accessory section.

**POLY-TIER SUPPORTS**–36 in. to 120 in. support heights in 6 in. increments. Knee braces supplied.

**CEILING HANGERS**–5/8 in. dia. x 8 ft. long unplated rods fully threaded. Other lengths and galvanized rods available.

**MOTORS**–Energy efficient, single phase, brakemotor, other characteristics. 2 HP maximum.

**ELECTRICAL CONTROLS**–One direction manual start switch, reverse drum switch, non-reversing and reversible magnetic starters, push button stations. AC variable frequency drive.

\*NOTE: Capacity affected with these options.

