



**ELEVATE
YOUR
STANDARDS®**

GUARDING



EdgeGard™ Dock Gates

**Straight and Folding-Rail
Designs Safely Protect
Personnel and Equipment**

EdgeGard™ Dock Gates from Wildeck are durable, reliable and safe. They are easy to install and operate, and provide an effective barrier for personnel and equipment working near open dock doors, truck loading pits or other hazardous areas.

- ▶ **Easy to Install**
- ▶ **Easy to Operate**
- ▶ **Easy to Access**
- ▶ **Easy to Protect**
- ▶ **Easy to Own**

Unique Folding-Rail design protects wider areas and minimizes the required gate clearance height.

“The Wildeck® EdgeGard™ gate is far superior for protecting personnel near our loading dock than the old chain gate we were using. When the EdgeGard is lowered into position, it's less likely that an individual will stumble off the dock during active packaging or truck loading activity.” – Satisfied Plant Manager



EdgeGard™ Dock Gates have Wildeck® quality built in. They are available as a Straight-Rail Gate, or unique Folding-Rail design that protects wider openings and minimizes the required clearance height. When properly anchored, EdgeGard™ gates meet the 200 lb. OSHA 1910.23 load force protection requirement.

The smooth cantilever action of Wildeck's innovative gate design ensures easy operation and long service life. When raised, the gate completely clears the opening offering unimpeded traffic flow and maximum accessibility. When closed, the gate is held securely in place and does not move.

Contact a Wildeck® sales representative today to learn more about EdgeGard™ Dock Gates, Wilgard® guard rail, or other Wildeck® safety guarding products – because quality and safety matter.

Straight-Rail Gate is ideal for standard dock widths.

EDGE GARD™ DOCK GATE

GENERAL SPECIFICATIONS

FEATURES AND BENEFITS:

- ▶ EdgeGuard™ Gate top rails are 42" high (above floor level) when closed.
- ▶ Available in four configurations to adapt to your application requirements.
 - ✓ Straight-Rail Gate: 8 ft. or 10 ft. Clear
 - ✓ Folding-Rail Gate: 10 ft. or 12 ft. Clear
- ▶ Requires minimal floor space and is easily assembled and installed.
- ▶ Strong balanced construction withstands 200 lbs. top rail pressure.
- ▶ Counterbalanced gas cylinders allow easy lifting and safe gate operation.
- ▶ Meets OSHA 1910.23 load force protection requirement.
- ▶ Black safety stripe on bright yellow paint finish ensures high visibility.
- ▶ Quality Wildeck® gates are manufactured in the USA and provide a long service life.

SPECIFICATIONS:

- ▶ Weight:
 - ✓ Straight-Rail Gate: 62 lbs. (8 ft.)
67 lbs. (10 ft.)
 - ✓ Folding-Rail Gate: 85 lbs. (10 ft.)
91 lbs. (12 ft.)
- ▶ Installation Footprint:
(Overall Width and Height Clearance When Raised)
 - ✓ Straight-Rail Gate: 110" W x 143" H (8 ft.)
or 134" W x 167" H (10 ft.)
 - ✓ Folding-Rail Gate: 141" W x 109" H (10 ft.)
or 144" W x 116" H (12 ft.)
- ▶ Assembly Hardware and Instructions Included
- ▶ Anchors Are Not Provided
- ▶ Painted Safety Yellow for High Visibility

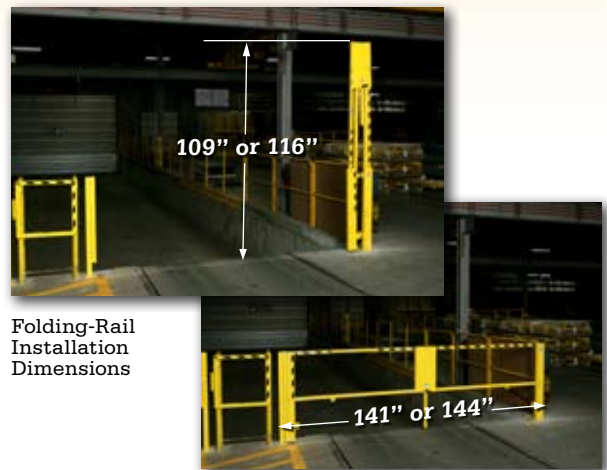
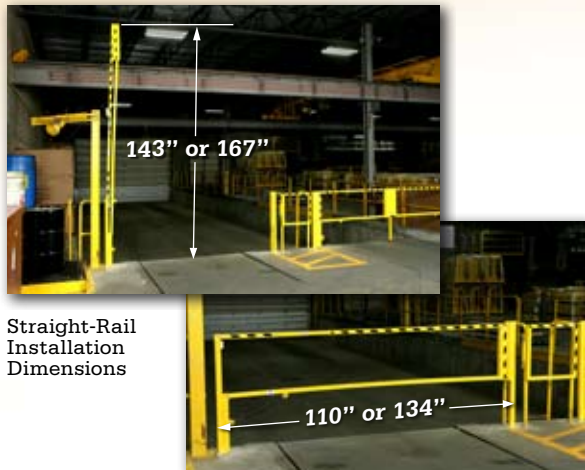

APPLICATIONS:

- ▶ Dock Doors & Shipping Areas
- ▶ Truck Loading Pits
- ▶ Isolate Restricted Areas
- ▶ Separate Work Zones
- ▶ Warehousing and Storage
- ▶ Distribution Centers
- ▶ Manufacturing Facilities
- ▶ Auto Service Shops – Parts Rooms
- ▶ Retail - Back Rooms, Inventory and Fixture Storage Areas
- ▶ Buildings of Worship
- ▶ Hospitals – Storerooms, Maintenance
- ▶ Schools, Universities, Colleges
- ▶ Military & Government Facilities
- ▶ ... and many other applications



ELEVATE
YOUR
STANDARDS®

P.O. Box 89 • 405 Commerce Street
Waukesha, WI USA 53186
262-549-4000 • 800-325-6939
FAX 262-549-3466 • info@wildeck.com
www.wildeck.com