

Straight and Knuckled High Profile Span-Track install **on** pallet rack beams. For each type of carton, install the first level of track following the instructions below and test for pitch before installing additional levels.

**1 SET BEAMS**

Set front pallet rack beam to desired discharge elevation. Set rear beam at higher elevation for flow (see chart).

PRODUCT	PITCH PER FOOT
Totes	3/4" to 7/8"
1-10 Lb. cartons	7/8" to 1-1/8"
10-30 Lb. cartons	7/8" to 1"
30-60 Lb. cartons	3/4" to 7/8"

Retainer Angle installs on top outside (aisle side) edge of front and rear beams

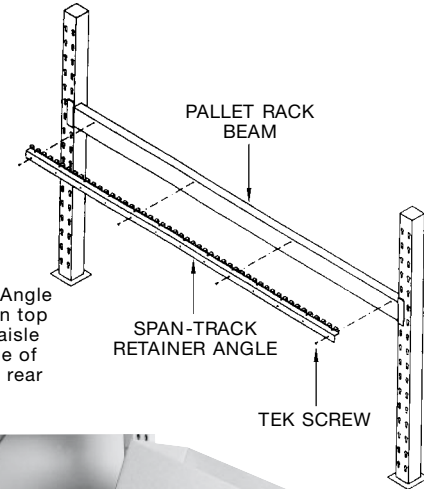

**2 ATTACH RETAINERS**

Attach pre-punched retainer angles to **outside of front and rear beams** using supplied tek screws (screws should be minimum 2 ft. o.c.)

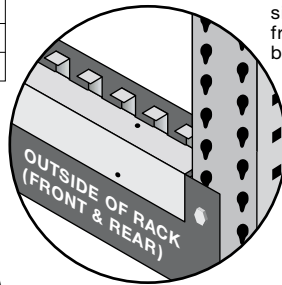

When installing Knuckled End Span-Track, angled end of track **MUST** extend free and clear of front beam. Long, straight part of track should rest between retainer teeth.

**3 ADD TRACK**

Locate lock arm at infeed end of track (rear beam) and (with arm in unlocked position) hook onto teeth of rear retainer for desired front-to-back track position and overhang.\* Adjust left-to-right to suit cartons being used. Flip lock arm to locked position.

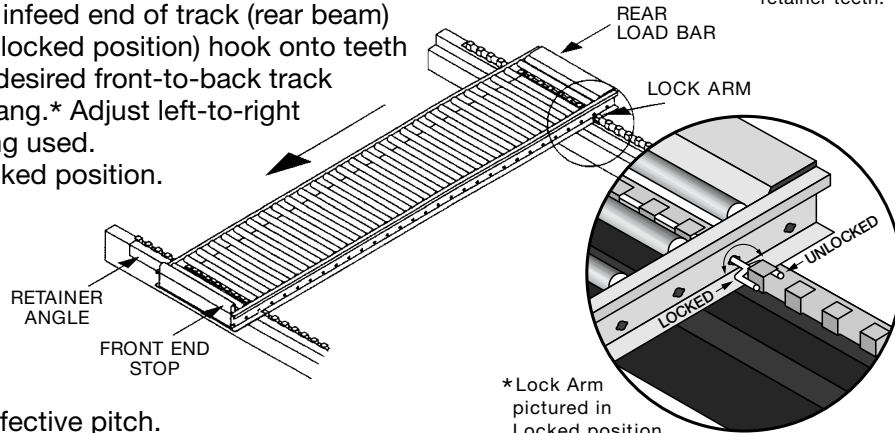

\*Lock Arm pictured in Locked position against retainer, and in Unlocked position outside retainer. **NOTE:** Lock Arm is repositionable through holes in side channels. Use holes at end of track for track flush with beam. Use other holes if overhang (up to recommended maximum) is desired.

**4 TEST PITCH**

Test installed track section for product flow to determine if rear beam needs readjustment for effective pitch.

**IMPORTANT:** Track section to be tested should be loaded and allowed to sit for 24 hours. Then remove cartons at pick face and check resulting flow. This is the most reliable way to ensure proper flow for your particular products and storage environment.

See reverse side for Deck Span-Track installation instructions.



Setting the Standard for Carton Flow

