

RoughDeck®

*Low Profile Floor Scale
HP, HP-H, HC and ROUGH-N-READY*

Installation Manual



RICE LAKE®
WEIGHING SYSTEMS

To be the best by every measure™

Contents

- 1.0 Introduction..... 1**
 - 1.1 General Description 1
 - 1.2 Model Designations 1
 - 1.3 Operating Requirements..... 1

- 2.0 Installation..... 2**
 - 2.1 Overview 2
 - 2.2 Site Preparation 2
 - 2.3 Unpacking 2
 - 2.4 Assembly 3
 - 2.4.1 Installing and Adjusting Feet 3
 - 2.4.2 Mounting Plate Installation..... 3
 - 2.5 Junction Box Connections 4
 - 2.5.1 Electrical Interface to the Indicator..... 4
 - 2.6 Pit Installation..... 5
 - 2.7 Access Ramps..... 6

- 3.0 Adjustments and Calibration 7**
 - 3.1 Mechanical Adjustments..... 7
 - 3.2 Corner Correction..... 7
 - 3.3 Calibration Procedure..... 8

- 4.0 Service Information 9**
 - 4.1 Troubleshooting Guide..... 9
 - 4.2 Periodic Maintenance..... 9
 - 4.3 Load Cell Replacement 10
 - 4.3.1 Load Cell Wiring to Junction Box..... 11
 - 4.4 Replacement Parts List and Accessories 12
 - 4.4.1 Pit Frames.....12
 - 4.4.2 Access Ramps12
 - 4.4.3 Load Cells.....13

- 5.0 RoughDeck Limited Warranty..... 16**



Technical training seminars are available through Rice Lake Weighing Systems. Course descriptions and dates can be viewed at www.ricelake.com or obtained by calling 715-234-9171 and asking for the training department

1.0 Introduction

1.1 General Description

The RoughDeck® Floor Scales are fully electronic, low profile load receivers. The RoughDeck scales are available in sizes from 30 in x 30 in (.76 m x .76 m) to 96 in x 120 in (2.44 m x 3.05 m), and capacities from 2K- to 30K-lbs (1000–15000 kg).

All models use four corner-mounted, FM-approved load cells, with the cells recessed into the frame channels for protection. Also included is a signal-trim summing board enclosed in a stainless steel, NEMA 4X junction box for any necessary corner corrections. All models come pre-trimmed; corner corrections should not be necessary.

Load cell cables are enclosed in conduit through the main channels, and held down with replaceable cable ties near each corner, eliminating the possibility of cable damage in portable applications. Also useful for portable applications are threaded corner holes in the deck for removable eyebolts to allow lifting the scale from above with chains. Because of the possibility of foot and load cell damage from forklift tines, the scale should always be lifted from above with chains through the eyebolts.

The adjustable feet are used to allow leveling the scale to make up for minor floor irregularities. For permanent installations, two of the four feet can be held in place on the floor with optional floor mounting plates to guard against deck movement.

Other available options include custom frames for pit installations, and access ramps for all sizes and models of the RoughDeck. Decks designed for use in pits can be ordered with holes drilled in the deck directly above each foot for adjusting foot height with a screwdriver from above. See Section 4.4 on page 12 for replacement part and optional equipment part numbers.

1.2 Model Designations

The model identification label is located on the side of the frame next to the slide-out junction box. Include both model number and serial number when ordering replacement parts.

NOTE: A duplicate label is affixed inside the junction box opening.

The following model designations are used to describe the different scale versions:

HP (Rough-n-Ready)— Mild steel, high precision, NTEP-certified as “legal-for-trade” and FM-approved load cells.

HP-H — 20K- and 30K-lb capacity HP models.

HC — Similar to HP models, the HC includes overload stops at each corner of the platform. This model is approved by Measurement Canada (formerly LMB) and available for use in Canada.

1.3 Operating Requirements

The following are basic operating requirements for the RoughDeck floor scale.

Electrical Grounding

For systems where the scale is connected to a 115 VAC circuit, the indicator must be directly connected to an earth ground with a ground interface cable of no more than 3Ω resistance throughout its length.

Load Cell Excitation

Rated Excitation: 10 VDC

Maximum Excitation: 15 VDC

Grade Level Requirements

The supporting surface for the four feet of the scale must be level within $\frac{1}{4}$ in. of horizontal.

End Load Capacity

200% full scale at 1000 lbs

100% full scale at 2000 lbs, 5000 lbs, and 20,000 lbs

80% full scale at 10,000 lbs

66% full scale at 30,000 lbs

Nominal Scale Height

2K–10K lb (1000–5000 Kg) models: 3.5 in (89 mm)

20K lb (10000 kg) models: 4.0 in (102 mm)

30K lb (15000 kg) models: 5.0 in (127 mm)

2.0 Installation

2.1 Installation Overview

Standard installation of the RoughDeck floor scale consists of the following steps:

1. Select a site
2. Check levelness and smoothness of site
3. Unpack scale
4. Adjust the four feet on the scale
5. Install mounting plates to the floor
6. Connect cable to junction box and indicator
7. Calibrate the unit

Pit installations and access ramps are described in Sections 2.6 and 2.7.

2.2 Site Preparation

The scale must not be loaded beyond its capacity, even momentarily. Do not select a site where overweight loads would have to maneuver to avoid crossing the platform. Avoid areas where the scale might receive damaging side impacts from wheels or forklift tines, or shock damage from falling objects. Avoid areas where water may damage a scale not meant for a washdown environment.

The interface cable between the scale and the indicator must be protected against crushing, cutting, or moisture damage. If the chosen site has such potential dangers, some method of protection, such as running the cable in conduit, will be necessary.

In operation, the scale must be level within $\frac{1}{4}$ inch. Either choose a site where the floor is close to this standard to avoid excessive shimming, or modify the floor at the chosen site to meet this standard.

2.3 Unpacking

Remove all packing material and inspect scale for visible damage caused during shipment.

All RoughDeck models have threaded holes in the deck to allow installation of eyebolts with shoulders for use when lifting the scale with chains or using a spreader bar.

NOTES:

- 5 ft x 5 ft platforms or less with a capacity no greater than 10,000 lbs, use one threaded center hole for lifting.
- Platforms larger than 5 ft x 5 ft or having a capacity greater than 10,000 lbs, use two threaded holes in opposite corners for lifting.
- Use 1/2 in eyebolts in 2K-10K-lb capacity scales, 3/4 in eyebolts in 20K- and 30K-lb capacity models.



Caution

If lifting the scale using a spreader bar, use only a properly designed spreader bar as shown in Figure 2-1. Lifting force must be vertical to avoid bending the eye bolts.

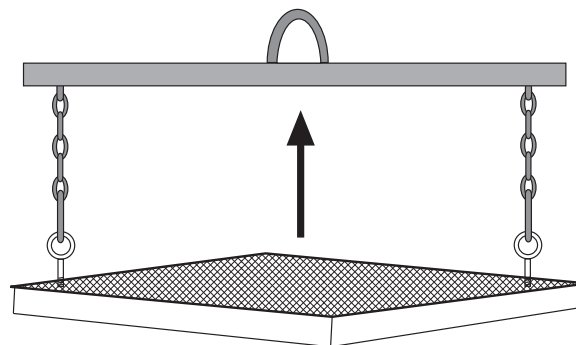

Large platform illustrated using two threaded holes for lifting.

Figure 2-1. Proper Lifting Technique

2.4 Assembly

The following paragraphs present instructions for installing and adjusting the scale feet and mounting plate installation.

2.4.1 Installing and Adjusting Feet

For load cell protection during shipping, the scale feet are shipped detached from the load cells. The feet are secured to the bottom of the shipping pallet along with the load cell cable, strain relief fitting and product literature. Remove all parts from the envelope.

Screw one foot into each load cell and turn all the way in until the foot touches either the load cell or the underside of the deck. Then unscrew each foot three complete turns.

Place a spirit level on the deck. Adjust any “high” corners not in contact with the floor by further unscrewing the feet on those corners until they just contact the floor surface. When all feet are in contact with the floor, check the deck with the spirit level to be sure the scale is within $\frac{1}{4}$ inch of level.

2.4.2 Mounting Plate Installation

For permanent applications, the scale should be secured to the floor to prevent sideways movement. Two mounting plates, with holes that slightly exceed the foot diameter, are available as an option for that purpose.

Lift the scale so that the feet are approximately one inch off the floor. Slide mounting plates under two diagonally opposed feet. Lower the scale back to the floor, and position the plates as shown in Figure 2-2 so that the bolt-down holes are accessible from above.

Using the mounting plates as templates, drill pilot holes into the floor for suitable anchor bolts. Bolt the plates to the floor using $\frac{1}{2}$ -in anchor bolts ($\frac{3}{4}$ -in bolts for 20K and 30K-lb capacity scales). Recheck foot adjustment and deck level after this operation.

For installations using access ramps, mounting plates are not necessary as the ramps have built-in mounting plates to secure the scale feet.

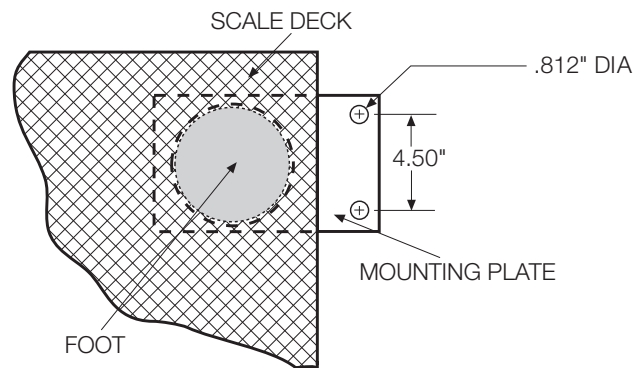

Figure 2-2. Mounting Plate Installation

2.5 Junction Box Connections

The indicator terminal strip is used to connect the main cable to the indicator which is shown in Figure 2-3. Determine the indicator's load cell input connections from the operating manual. Run a cable from your indicator terminal into the junction box and make the connections. The following table shows the correct junction box connections using the cable color code.

Cable Color Code	Junction Box
Red	+ Excitation
Black	- Excitation
Green	+ Signal
White	- Signal
Brown	Shield
Yellow	+ Sense
Blue	- Sense

Table 2-1. Junction Box Connections

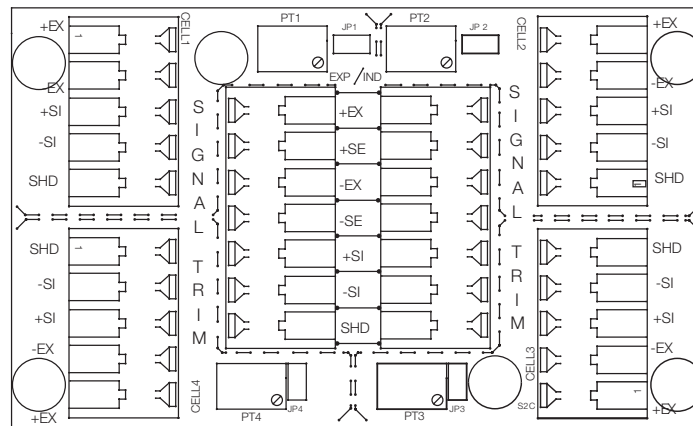
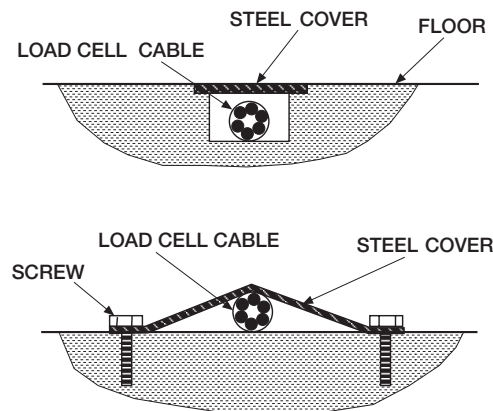

Figure 2-3. Junction Box Indicator Terminal

2.5.1 Electrical Interface to Indicator

Twenty feet of 6-wire cable to connect the scale to the weight indicator is supplied with each scale. The cable must be routed to the indicator in a manner that will protect the cable from damage. Two methods of cable protection in non-washdown applications are shown in Figure 4. When planning cable routing with either of these two methods, leave a loose coil of excess cable under the scale to facilitate future lifting of the scale for servicing or cleaning.



When the interface cable is protected and in its final position, complete connections to the indicator. See indicator installation manual for wiring information.

If necessary, trim corners as described in Section 3.2.

Check all strain relief fittings for tightness.

Slide the junction box assembly into the cutout and secure it with the two #10 x $\frac{3}{8}$ " screws provided.

2.6 Pit Installation

Any of the RoughDeck models can be installed in a shallow pit using the optional RoughDeck Pit Frame. Optional height-adjustment holes are available. The following site considerations and pit frame drawings are meant only as a brief overview of the principles involved with mounting the scale in a floor-level pit. The pit must be installed in a suitable poured-concrete foundation according to standard construction practices.

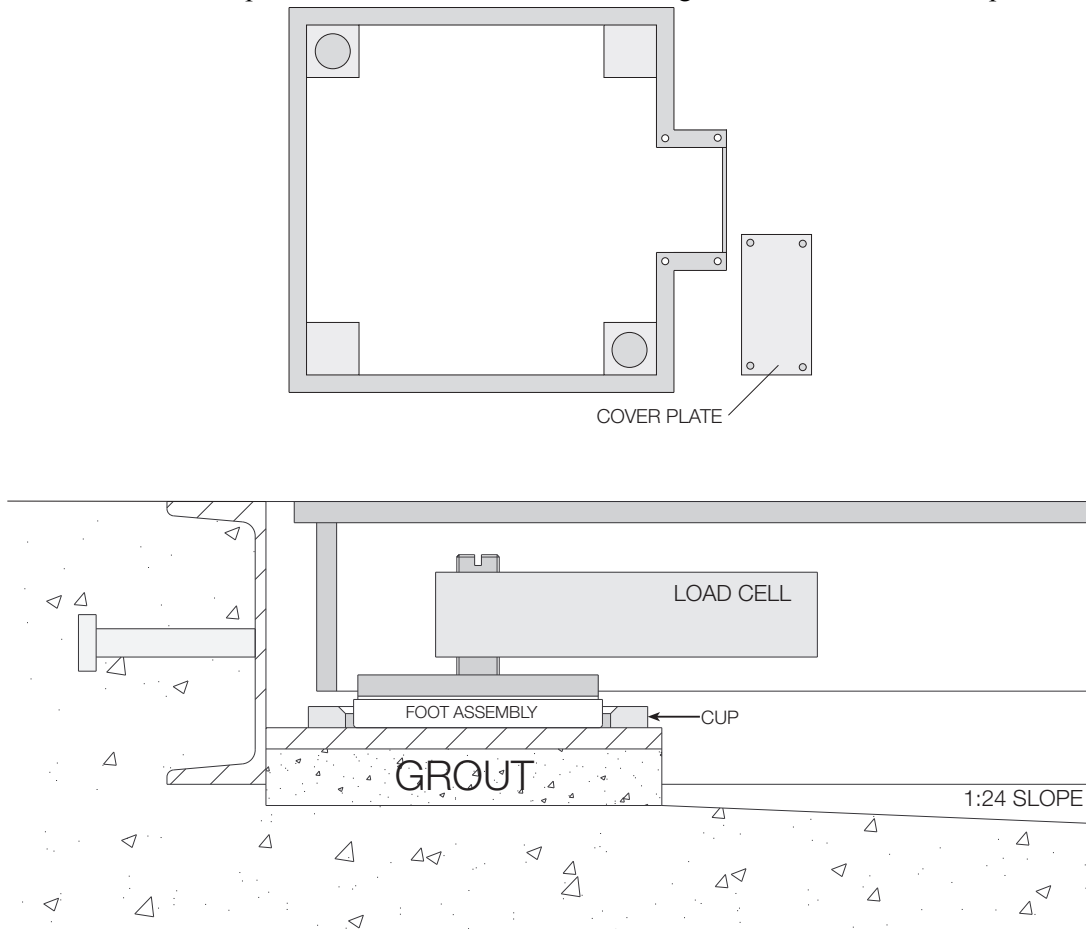

Figure 2-4. Section Showing Installed Heavy Capacity (HP-H Model) RoughDeck and Pit Frame

Site Considerations

Debris, floor sweepings, or material spills may accumulate in the pit and interfere with scale operation. You should periodically clean the pit. All RoughDeck models have threaded holes for eyebolts so the scale can be easily lifted from the pit.

Weight overloads, even momentary ones such as driving a loaded forklift over a scale corner, will damage load cells. Plan the pit location out of main traffic areas to prevent such accidental damaging overloads.

A 1:24 slope is recommended for the pit, with full grouting under the corner pads as shown in Figure 2-4.

NOTE: Corner pads must be fully grouted.

2.7 Access Ramps

Access ramps for RoughDeck floor scales are designed to bolt to the floor, with built-in mounting plates that attach to the scale feet. When used with access ramps, side movement of the scale is automatically eliminated, and no other mounting plates are necessary.

Access ramps can only be attached to the scale on one of the two scale sides that are perpendicular to the longitudinal axis of the load cells. For example, the scale shown in Figure 2-5 could have an access ramp on the left side as shown, and/or on the right side. The top and bottom sides, however, will not accept the ramp mounting plates.

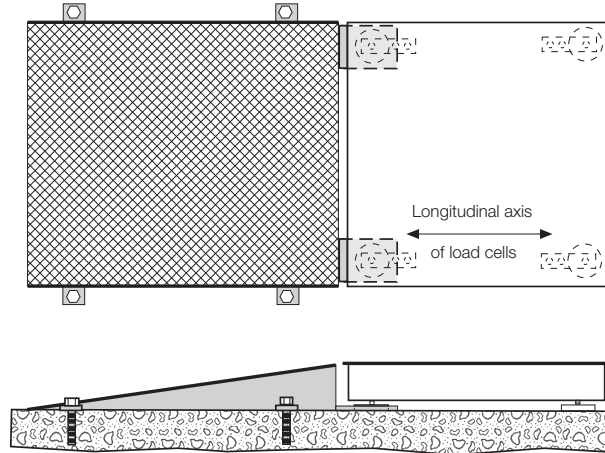

Figure 2-5. Optional Access Ramps

See Tables 4-3 and 4-4 in Section 4.4.2 for information about available access ramps.

3.0 Adjustments and Calibration

3.1 Mechanical Adjustments

To accommodate minor floor unevenness, scale feet can be used to adjust scale height up or down a fraction of an inch. Adjust the feet by hand (lift the scale corner slightly with a pry bar) until all feet are contacting the floor equally. No jam nuts are supplied for locking the feet, as there is a slight decrease in accuracy when jam nuts are tightened. However, if you feel that your application requires you to secure the feet, we suggest using Teflon tape or Loctite.



Caution

When adjusting scale feet, use care to prevent scale foot from bottoming out against the underside of the load cell. Also, the foot stem may be damaged by bending or stripping threads if extended beyond the maximum height adjustment.

When height adjustments are complete, recheck level of the deck with a spirit level. The deck must be level within $\frac{1}{4}$ ".

3.2 Corner Correction

All assembled RoughDeck scales are delivered with the junction box corner-trimmed. Corner trimming is only necessary after replacing a load cell.

To calibrate the scale, the output from each load cell must be matched by adjusting the signals with potentiometers at the junction box—a process known as trimming.

Remove the junction box cover and identify the correct load cell terminal corresponding to each corner (labeled CELL 1, CELL 2, and so on). See Figure 4-4 on page 11 for scale deck corner numbering.

The indicator must be connected and calibrated approximately, but it need not indicate the exact weight value. A test weight will be required. The recommended test weight for all RoughDeck models is 25% of scale capacity: for example, 500 lbs for 2K-lb models, 5000 lbs for 20K-lb models.

With no weight on the scale, zero the indicator. Then turn all four potentiometers (shaded areas of Figure 3-1) to increase the reading until a clicking sound is heard from each potentiometer. This ensures the maximum signal from each load cell.

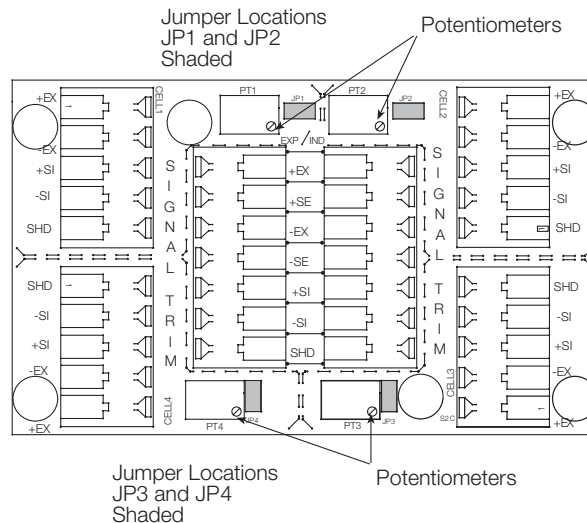

Figure 3-1. Trim Potentiometers

With all potentiometers at full signal, place the test weight over one corner and record the indicated weight. Repeat the process for each of the other three corners. The load cell with the lowest corner reading will be used as a reference point and will not be trimmed.

Next, place the test weight over one of the other three corners and use that cell's potentiometer to adjust the cell output down to the reference cell output. Repeat this procedure with the other two high corners.

Adjustments are somewhat interactive, and adjusting the three higher outputs may affect the reference cell output, especially in smaller scale decks. Rezero the indicator and repeat the test until all corners read within $\pm 1\%$ of the test weight used.

3.3 Calibration Procedure

Refer to the indicator manual to determine correct calibration procedures.

It is recommended that the scale be “exercised” before calibration to be certain that everything is seated. Load the scale to near capacity two or three times.

Then, with no load on the scale, place the indicator in its calibration mode and perform a zero calibration. Now place test weights on the platform equal to 70% - 80% of the scale’s capacity. If several weights are used, they should be evenly distributed around the platform. Perform a span calibration.

Remove the test weights and check the zero reading. Repeat the calibration process if necessary.

4.0 Service Information

4.1 Troubleshooting Guide

System does not operate - no display

- Power disconnected: *Check and reconnect.*
- Indicator fuse blown. *Replace fuse. Check for cause.*
- Interface cable cut or disconnected: *Repair.*
- Signal leads incorrectly installed at indicator: *Install according to indicator installation manual*

Display stays at zero

- Indicator faulty: *Service indicator*
- Load cell connections faulty: *Check cable connections in junction box and at indicator*

Erratic weights

- Vibration near scale: *Remove source of vibration or move scale.*
- Platform not level to within $\frac{1}{4}$ in: *Level scale by adjusting feet or shimming if necessary.*
- Load cell or cable water damage: *Replace.*
- Debris under load cells or platform: *Clean.*
- Indicator faulty: *Use simulator to test indicator for stability. Service indicator.*

Consistently high or low weights

- Indicator not properly adjusted to zero: *Zero the indicator according to indicator manual.*
- Platform binding: *Obtain adequate clearance for free platform movement.*
- Indicator not calibrated: *Calibrate according to indicator manual and Section 3.3*
- Load cells faulty: *Test and replace load cells if necessary.*
- Feet touching deck underside: *Adjust feet downward to provide clearance.*

4.2 Periodic Maintenance

The space between the platform side and pit frame, and the surface beneath the platform must be periodically cleaned to prevent debris build up. More frequent cleaning of these areas is necessary with scales mounted in pits.



Caution

Do not attempt to use scales with load cells that are not hermetically sealed in washdown applications. Water damage is a common cause of failure in non-hermetically-sealed load cells. Use care with high pressure steam washdowns for hermetically-sealed load cells. The steam may not damage the load cells, but the elevated temperatures may cause incorrect readings until the unit cools to room temperature.

4.3 Load Cell Replacement

Replacement load cells can be ordered from Rice Lake Weighing Systems according to the part numbers in the chart on page 9.

Lift scale with chains and proper spreader bar and remove foot, then remove defective load cell. Disconnect load cell cable from junction box and cut cable ties. When the cable is freed, pull cable out of the scale frame channels.

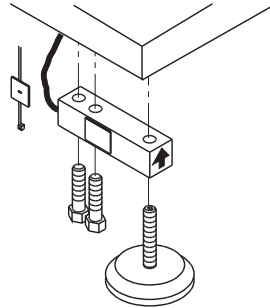

Figure 4-1. Load Cell Assembly

Follow the directions given below to install new load cells.

For Canadian HC models, overload stops should be loosened two full turns before installing new load cells. To reset overload stops after load cell installation, place a weight equal to 25% of the load cell capacity on the affected scale corner. Screw in the overload stop until the indicator reading changes. Then back off the overload stop 1/6 turn. Repeat for each corner where the load cell has been changed.

Lay out the four load cells near the corners where they are to be installed. Thread the cable from each load cell through the conduit tubing in the frame and into the junction box according to the wiring diagram in Figure 4-2.

Note that in Figure 4-2 both the scale and the junction box are viewed from the bottom. To verify correct load cell/junction box terminal matching, see the numbers on the terminals inside the junction box and the corner numbering diagram in Figure 4-4.

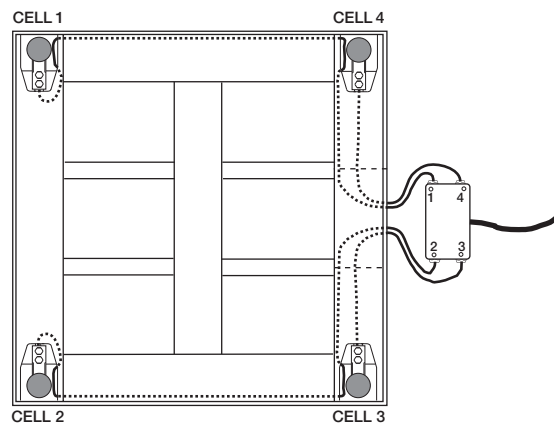

Figure 4-2. Bottom View of Scale

Check that the threaded holes for the load cell screws are free of debris. Use compressed air to blow out holes if necessary. Position load cells with alignment arrows point up toward the deck and loosely install the hex head cap screws provided, as shown in Figure 4-1. If the base is used with a pit frame or access ramp, position the load cell to maintain the dimension shown in Figure 4-3. With the torque wrench, tighten all bolts as follows (outboard bolts first):

- 2K–10K-lb capacities: Torque to 75 ft-lbs.
- 20K-lb and 30K-lb capacities: Torque to 250ft-lbs.

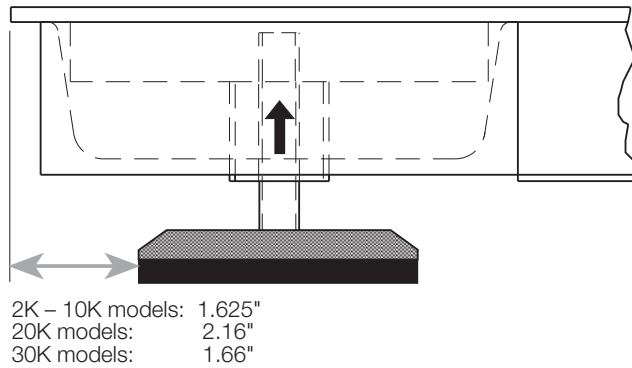

Figure 4-3. Foot Pad - Side View

Route the load cell cables near each corner so that the cable is free from possible contact with each foot. Hold the cable in position with the adhesive-backed cable ties supplied in the hardware kit.

Do not cut load cell cables. Coil extra cable before it enters the junction box, tie with cable ties, and insert the coils into the channel.

After coiling excess cable, pass each individual end of load cell cable through its cord grip in the NEMA 4X junction box.

Corner correction trimming and calibration is necessary after load cell replacement. Follow instruction in Sections 3.2 and 3.3.

4.3.1 Load Cell Wiring to Junction Box

The four load cells are each wired to their respective terminals in the junction box according to the corner numbering system shown in Figure 4-4, and the coloring code in Table 4-1.

Pull excess cable out of the junction box enclosure and tighten the cord grip dome nuts with a wrench. To be watertight, the nuts must be tightened to the point where the rubber sleeving begins to protrude out of the nut. Finally, pull on each of the four cables to make sure that they do not slip.

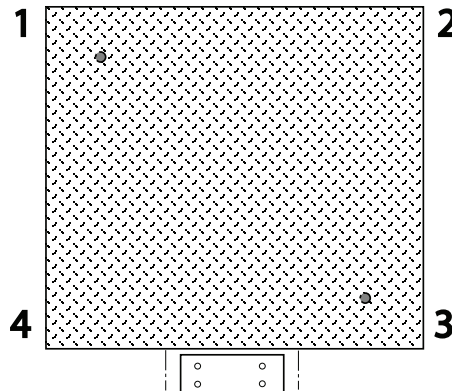

Figure 4-4. Corner Numbering - Top View

Color Cable Code	J-Box Terminal
Red	+ Excitation
Black	- Excitation
Green	+ Signal
White	- Signal
Bare or Clear	Shield

Table 4-1. Load Cell Wiring

4.4 Replacement Parts List and Accessories

The following table list the pit frames, access ramps, and replacement load cell part numbers for HP, HC, and HP-H model RoughDeck floor scales.

4.4.1 Pit Frames

Table 4-2 shows the pit frames available for RoughDeck scales.

Platform Size		Pit Frame for Model		
ft.	m	HP/HC	HP-H 20k	HP-H 30k
2.5 x 2.5	.76 x .76	18757		
3 x 3	.92 x .92	18759		
4 x 4	1.22 x 1.22	18761	39595	39608
4 x 5	1.22 x 1.53	18765	39596	39609
4 x 6	1.22 x 1.83	18767	39597	39610
4 x 7	1.22 x 2.13		39598	39611
5 x 5	1.53 x 1.53	18763	39599	39612
5 x 6	1.53 x 1.83	18769	39600	
5 x 7	1.53 x 2.13	18771	39601	39614
6 x 6	1.83 x 1.83		39602	39615
6 x 8	1.83 x 2.44		39604	
7 x 9	2.13 x 2.74		39605	
7 x 10	2.74 x 3.05		39606	39619
8 x 10	2.44 x 3.05		39607	39620

Table 4-2. RoughDeck Pit Frames

4.4.2 Access Ramps

Table 4-3 shows the standard access ramps available for the 2K-10K lb-capacity RoughDeck scales.

Ramp Width		Ramp Length		Ramp Height		Access Ramp for Model
ft.	m	ft.	m	ft.	m	HP/HC
2.5	.76	3	.92	3.5	89	69040
3	.92					69041
4	1.22					69042
5	1.53					69043
2.5	.76	4	1.22	3.5	89	69184
3	.92					69185
4	1.22					69186
5	1.53					69187

Table 4-3. RoughDeck Access Ramps (2K - Through 10K lb Models)

Table 4-4 shows the standard access ramps available for the 20K and 30K lb-capacity RoughDeck scales (HP-H models).

Platform Size		Pit Frame for Model		
ft.	m	HP/HC	HP-H 20k	HP-H 30k
2.5 x 2.5	.76 x .76	18757		
3 x 3	.92 x .92	18759		
4 x 4	1.22 x 1.22	18761	39595	39608
4 x 5	1.22 x 1.53	18765	39596	39609
4 x 6	1.22 x 1.83	18767	39597	39610
4 x 7	1.22 x 2.13		39598	39611
5 x 5	1.53 x 1.53	18763	39599	39612
5 x 6	1.53 x 1.83	18769	39600	
5 x 7	1.53 x 2.13	18771	39601	39614
6 x 6	1.83 x 1.83		39602	39615
6 x 8	1.83 x 2.44		39604	
7 x 9	2.13 x 2.74		39605	
7 x 10	2.74 x 3.05		39606	39619
8 x 10	2.44 x 3.05		39607	39620

Table 4-4. RoughDeck Pit Frames

4.4.3 Load Cells

Table 4-5 lists the replacement load cells for all RoughDeck models.

Capacity of Scale		Replacement Load Cell for Model	
lbs	kg	HP/HC	HP-H
1K	500	21528	
2K	1000	21528	
5K	2500	21530	
10K	5000	21532	
20K	10000		21534
30K	15000		21534

Table 4-5. Replacement Load Cells

5.0 RoughDeck Limited Warranty

Rice Lake Weighing Systems (RLWS) warrants that all RLWS equipment and systems properly installed by a Distributor or Original Equipment Manufacturer (OEM) will operate per written specifications as confirmed by the Distributor/OEM and accepted by RLWS. All systems and components are warranted against defects in materials and workmanship for five (5) years.

RLWS warrants that the equipment sold hereunder will conform to the current written specifications authorized by RLWS. RLWS warrants the equipment against faulty workmanship and defective materials. If any equipment fails to conform to these warranties, RLWS will, at its option, repair or replace such goods returned within the warranty period subject to the following conditions:

- Upon discovery by Buyer of such nonconformity, RLWS will be given prompt written notice with a detailed explanation of the alleged deficiencies.
- Individual electronic components returned to RLWS for warranty purposes must be packaged to prevent electrostatic discharge (ESD) damage in shipment. Packaging requirements are listed in a publication, "Protecting Your Components From Static Damage in Shipment," available from RLWS Equipment Return Department.
- Examination of such equipment by RLWS confirms that the nonconformity actually exists, and was not caused by accident, misuse, neglect, alteration, improper installation, improper repair or improper testing; RLWS shall be the sole judge of all alleged non-conformities.
- Such equipment has not been modified, altered, or changed by any person other than RLWS or its duly authorized repair agents.
- RLWS will have a reasonable time to repair or replace the defective equipment. Buyer is responsible for shipping charges both ways.
- In no event will RLWS be responsible for travel time or on-location repairs, including assembly or disassembly of equipment, nor will RLWS be liable for the cost of any repairs made by others.

THESE WARRANTIES EXCLUDE ALL OTHER WARRANTIES, EXPRESSED OR IMPLIED, INCLUDING WITHOUT LIMITATION WARRANTIES OF MERCHANTABILITY OR FITNESS FOR A PARTICULAR PURPOSE. NEITHER RLWS NOR DISTRIBUTOR WILL, IN ANY EVENT, BE LIABLE FOR INCIDENTAL OR CONSEQUENTIAL DAMAGES.

RLWS AND BUYER AGREE THAT RLWS'S SOLE AND EXCLUSIVE LIABILITY HEREUNDER IS LIMITED TO REPAIR OR REPLACEMENT OF SUCH GOODS. IN ACCEPTING THIS WARRANTY, THE BUYER WAIVES ANY AND ALL OTHER CLAIMS TO WARRANTY.

SHOULD THE SELLER BE OTHER THAN RLWS, THE BUYER AGREES TO LOOK ONLY TO THE SELLER FOR WARRANTY CLAIMS.

No terms, conditions, understanding, or agreements purporting to modify the terms of this warranty shall have any legal effect unless made in writing and signed by a corporate officer of RLWS and the Buyer.

© 2009 Rice Lake Weighing Systems, Inc. Rice Lake, WI USA. All Rights Reserved.

RICE LAKE WEIGHING SYSTEMS • 230 WEST COLEMAN STREET • RICE LAKE, WISCONSIN 54868 • USA