

Counter Weight Stackers

C62A and C74A

Installation, Operation and Service Manual

Model Number _____

Serial # _____

Date Placed in Service _____

**IMPORTANT: READ CAREFULLY
BEFORE INSTALLING OR OPERATING LIFT**

Part orders are subject to a \$50 minimum charge.



This manual was current at the time of printing. To obtain the latest, most updated version, please contact the Customer Service Department or go to our website: www.PrestoLifts.com -- you will find a complete list of current Owner's Manuals to print.

CONTENTS

SECTION 1:	
Introduction	4
SECTION 2:	
Safety	4
SECTION 3:	
Installation	4
A. Inspection	4
B. Removing from Pallet	4
SECTION 4:	
Operation	5
A. Operating Instructions	5
B. Daily Operations Maintenance Checks	5
Operator Instructions for Counterweight Lift	6
A. Preparation for Use	6
B. Counterweight Instructions	6
C. Capacity	7
D. Operations	7
SECTION 5:	
Battery Maintenance	8
A. Preparing to Charge a Battery	8
B. Locating the Charger	8
C. Precautions	8
D. Battery Charger Connection Precautions	8
SECTION 6:	
Maintenance	9
A. Instructions	9
B. Monthly Operations Maintenance Checks	9
C. Maintenance	9
SECTION 7:	
Troubleshooting	10
ORDERING REPLACEMENT PARTS	11
RESTOCKING POLICY	12
RETURN MAT'L S AUTHORIZATION (RMA) PROCEDURES	13
WARRANTY	14

LIST OF FIGURES :

Figure 1: Center of Load	7
Figure 2: Counterweight Stacker	10

SECTION 1

INTRODUCTION

This manual attempts to provide all of the information necessary for the safe and proper installation, operation and maintenance of Presto Lifts Inc. Battery Operated, Electric and Counterweight Stackers. It is important that all personnel involved with the installation, maintenance or operator of the stacker read this manual. Additional manuals are available upon request or at www.prestolifts.com.

Each of the Presto Lift Inc. stackers is equipped with nameplate, serial number and model identifications. Please refer to these numbers when ordering parts or requesting further information.

The Presto Lifts Inc. stackers are designed for lifting, lowering and positioning a wide variety of loads. WHERE UNIQUE SITUATIONS ARISE, WHICH ARE NOT COVERED IN THIS MANUAL, CALL PRESTO LIFTS FOR FURTHER INSTRUCTIONS.

The battery-operated stackers are designed for in-plant/non-hazardous locations only. These units are not for personnel lifting. All equipment is manually propelled and powered vertical travel.

SECTION 2

SAFETY

The battery-operated stackers are very powerful lifts capable of doing large amounts of work.

DO NOT INSTALL OR OPERATE THESE LIFTS WITHOUT CAREFULLY READING THIS MANUAL. In order to provide for the safe operation of these stackers, Presto Lifts Inc. has identified certain hazards that may occur during the installation, maintenance and use of these lifts. For safety reasons these units are designed to be serviced or repaired in the collapsed position. If performed properly, this will greatly reduce the possibility of injury.

WARNING!

- Do not perform any repair work on lifts if there is a load on the forks or platform.

- Do not perform any repair work if the forks or platform is in the raised position.
- All personnel must stand clear of the lift while in motion.
- Do not put hands or feet under the forks or platform.
- Do not stand underneath the forks or platform.
- Do not stand in front of the stacker while in motion.
- Do not stand, sit or climb on the lift.
- Do not use the lift on soft, uneven or unstable surfaces.
- Do not exceed the load center or capacity.

SECTION 3

INSTALLATION

A. INSPECTION:

Upon receipt of the stacker, inspect the equipment completely to determine if there is any shipping damage, and that the lift is complete. Presto Lifts Inc. tests and inspects every piece of equipment prior to shipment. If damage is apparent, a freight claim must be filed with the freight company. Do Not use the lift if there appears to be any damage. With the lift in a lowered position, check the following:

- Check for signs of damage especially to the back cabinet that houses the battery, electrical/hydraulic power pack.
- Check all connections for tightness. Is there hydraulic fluid visible?
- Check base frame for dimensions and structural integrity.
- Inspect for any bent or damaged metal parts.

B: REMOVING FROM PALLET

Each of the Presto stackers is shipped out on a pallet or skid. Prior to removing the unit from the pallet or skid, remove all tie down straps and packaging. Visually inspect the unit as closely as possible.

With an overhead hoist or forklift, carefully pick up the

lift taking into consideration the center of gravity of the unit. If you choose to pick the unit with an overhead hoist, use a nylon sling and hoist with a minimum of 2,000-lb. capacity. The nylon sling will not do any damage to the steel construction of stacker. Pick the unit up by the top cross member of the lift. Be careful of the stacker swinging once fully lifted off the pallet or skid. Have all personnel completely cleared from the area.

Pick the unit up approximately six inches above the pallet or skid. Once raised, remove the pallet or skid from below the lift. Do Not move the lift around in the air, once secured in the raised position, remove the pallet from below and place the stacker on the ground.

SECTION 4

BATTERY MAINTENANCE

A. PREPARING TO CHARGE A BATTERY

1. Be sure area around lift and the battery is well ventilated while battery is being charged.
2. The battery terminals, connections and wiring including the plug in the battery box and charger connections should be clean and free of corrosion. When cleaning any of these components wear a face shield or other suitable protective eyewear.
3. For a sealed battery (a battery without cell caps) carefully follow the manufacturer's recharging instructions that are provided with the battery. If you do not have a copy of these instructions or the instructions for the battery charger they are available free of charge by calling Presto Lifts @ 1-800-343-9322.

FOR UNITS NOT EQUIPPED WITH A TWIST-LOCK, PREWIRED CHARGER PLUG FOLLOW THESE ADDITIONAL PRECAUTIONS

1. Check polarity of battery posts. POSITIVE (POS, P, +) battery post usually has larger diameter than NEGATIVE (NEG, N, -) battery post.

2. Determine which post of battery is grounded (connected) to the chassis of the machine. Connect the NEGATIVE (Black) clip from the battery charger to the machine chassis as far away from the battery as possible.

3. The POSITIVE (red or white) clip from the battery charger to the POSITIVE (POS, P, +) post of the battery.

4. When making each connection, twist or rock clip back and forth several times to make a good connection and to reduce the risk of a clip slipping off and creating a spark. Do not twist or rock clip on the battery after the second clip connection is made.

5. When disconnecting the charger, disconnect AC cord from the electrical outlet before removing any clips from battery or chassis.

Read, understand and follow all battery and battery charger manufacturer's specific precautions while working with and/or charging batteries.

B. LOCATING THE CHARGER

1. Locate charger as far away from battery as the cables permit.
2. Do not operate charger in a closed area or restrict ventilation in any way.
3. Locate charger at least 18" above the floor.

C. PRECAUTIONS FOR GROUNDING AND AC POWER CORD CONNECTION

Charger should be grounded to reduce risk of electric shock. Charger is equipped with an electric cord having an equipment-grounding conductor and grounding plug. The plug must be plugged into an outlet that is properly installed and grounded in accordance with all local codes and ordinances.

DANGER

Never alter the AC cord or plug provided. If it

will not fit outlet, have proper outlet installed by a qualified electrician. Improper connection can result in a risk of an electric shock.

D. BATTERY CHARGER CONNECTION PRECAUTIONS

CAUTION

Connect and disconnect the DC output plug (or clips) only when the AC cord is disconnected from the electric outlet. Never allow clips to touch each other.

1. To charge the unit, plug the charger into the 110 volt wall outlet. The charger is pre-wired to the battery.
2. Disconnect the charger from the 110 volt wall outlet once the indicators read fully charged.

SECTION 5 OPERATION

A. OPERATING INSTRUCTIONS:

Before operation of the counterbalance stacker, make sure the proper counter balance ballast is installed.

1. To raise lift, push control handle.
2. To lower lift, pull control handle.
3. Whenever the control handle is released, the lift stops.

AUTHORIZED OPERATORS SHOULD READ AND UNDERSTAND ALL INSTRUCTIONS, PRECAUTIONS AND WARNINGS. IMPROPER USE OF THIS LIFT TRUCK COULD RESULT IN INJURY AND/OR DAMAGE TO LOAD AND EQUIPMENT.

- Inspect the lift for damaged or worn parts. *Do not* use if not in safe operating condition.
- Use lift on hard level surfaces only.
- Make sure load is evenly distributed, not loose or unstable, and is as far back on platform or forks as possible. *Do not* pick up loads on tips or forks or edge of platform.
- For fork models, adjust forks to the maximum

practical width. Pick up loads on both forks (not one).

- *Do not* overload. Check load center and load weight capacities on manufacturer's nameplate.
- Make sure travel and work area is clear of obstructions.
- Check overhead clearance before lifting loads or transporting.
- Make sure floor lock pad is in firm contact with floor before lifting load, lowering load or using as a workstation.
- Brace or block lift when sliding loads on or off platform or forks.

B. DAILY OPERATIONS MAINTENANCE CHECKS:

1. Battery (If Equipped)

- A. Check for corroded and loose terminals. A white powder substance will be present if there is any existing corrosion.
- B. Visually inspect for any cracks or damage to the casing.
- C. Check for loose battery tie-downs.

2. Charger (If Equipped)

- A. Inspect wire connections.
- B. Check power cord for nicks/damage.
- C. Check charger for proper mounting.

Hydraulic System

- D. Inspect pump and cylinder for oil leaks.
- E. Check hydraulic oil level.
- F. Check hydraulic fittings and hoses.
- G. Check ram for nicks/damage.

3. Frame Assembly

- A. Check floor lock.
- B. Check placement of safety screen.
- C. Check chain roller assembly connections.
- D. Check for any worn or damaged parts.

SECTION 6

MAINTENANCE

Operation of PRESTO Hydraulic Lifts is very simple — as is their construction. They require very little maintenance. Reasonable care will result in excellent trouble-free performance. PRESTO Hydraulic Lifts are designed for one-man operation and ease of performance.

A. INSTRUCTIONS:

- Grease wheels and casters at least once a month to maintain easy roll of lift.
- Use only Hydraulic Oil (Citgo AW 32) in the hydraulic system.
- *Do not* overload your lift.

B. MONTHLY OPERATIONS MAINTENANCE CHECKS:

1. Battery (maintenance free)

- A. Clean terminals.
- B. Clean battery compartment area.
- C. Check specific gravity — fully charged battery should read 1265. Using a hydrometer that measures specific gravity can check this.

2. Hydraulic System

- A. Clean and inspect hydraulic cylinder.
- B. Lubricate chain with a rust inhibitive lubricant.
- C. Check chain tension. The chain should be tight enough so that it does not come off of the roller assembly.

3. Frame Assembly

- A. Clean and lubricate all roller bearings and cam followers.
- B. Clean and inspect all welds.
- C. Check wheels for wear and damage.
- D. Inspect nameplate for legibility. Place the serial and model number shown on the nameplate on the cover of the manual for future reference.

C. MAINTENANCE

The attached bulletin outlines maintenance instructions and parts. A visual check should be made on a daily

basis to assure the safety of the lift.

Operator Daily Checks

DAMAGE: Check for bent, dented, worn or broken parts.

LEAKS: Check hydraulic system.

WHEELS AND CASTERS: Check for wear and that they are turning smoothly.

LIFT CHAINS: Check to see that they are in place and not loose.

FORKS: Check that they are in place and stable.

LIFT SYSTEM: Check to assure that there is no binding or excessive play in the platform or fork back plate. Check for quiet and smooth operation of the lift cylinder.

FLOOR LOCK: Check to assure pad is contacting floor and holds truck in place.

CABLES; WIRES: Check that there are no loose cables or wires.

CAUTION:

**DO NOT USE LIFT IF IT IS NOT
OPERATING PROPERLY,
OR APPEARS UNSAFE IN ANY WAY!**

CAUTION:

**DO NOT OVERLOAD!
COUNTER WEIGHT LIFT
WILL TURN OVER**

**Do not exceed 13 inch load center
Always check that counter weight (ballast)
is adequate for weight of load being lifted.**

Do not use on ramps or inclines.

Only on smooth level surfaces.

SECTION 7

TROUBLESHOOTING

IF LIFT DOES NOT RISE TO FULL HEIGHT — check for leaks or shortage of oil. Maintain the proper oil level. To check oil level, follow these instructions:

A. Old style power unit (vertical)
 On left hand side, on top of oil well, you will find a hexagon cap screw which is also a dipstick. Remove the cap screw and fill oil well with hydraulic oil. Oil should reach notch on dipstick.

B. New style power unit (horizontal)
 Unscrew the fill plug located on the top of the reservoir. The oil level will be 1-2 inches down from the top. If the oil level is down, fluid can be added at this point.

IF THE LIFT TENDS TO CREEP DOWNWARD UNDER A LOAD — a speck of dirt may be obstructing the seating of the valve and allowing leakage. To correct, follow these instructions:

- Raise lift to full lifting height and then lower it to lowest point of lift. It may be necessary to do this five or six times. In lowering the lift, lower it in stages, that is, lower the lift six inches to a foot at a time. This will dislodge the dirt and lift will operate properly.

FIGURE 2: Counterweight Stacker

Component Identification	
Item No.	Description
1	Powerpack Assembly
2	12 volt Battery
3	C100 Floor Lock
4	Lever – Power Up
5	Counterweight – 600 lbs.
6	Phenolic Swivel Wheels

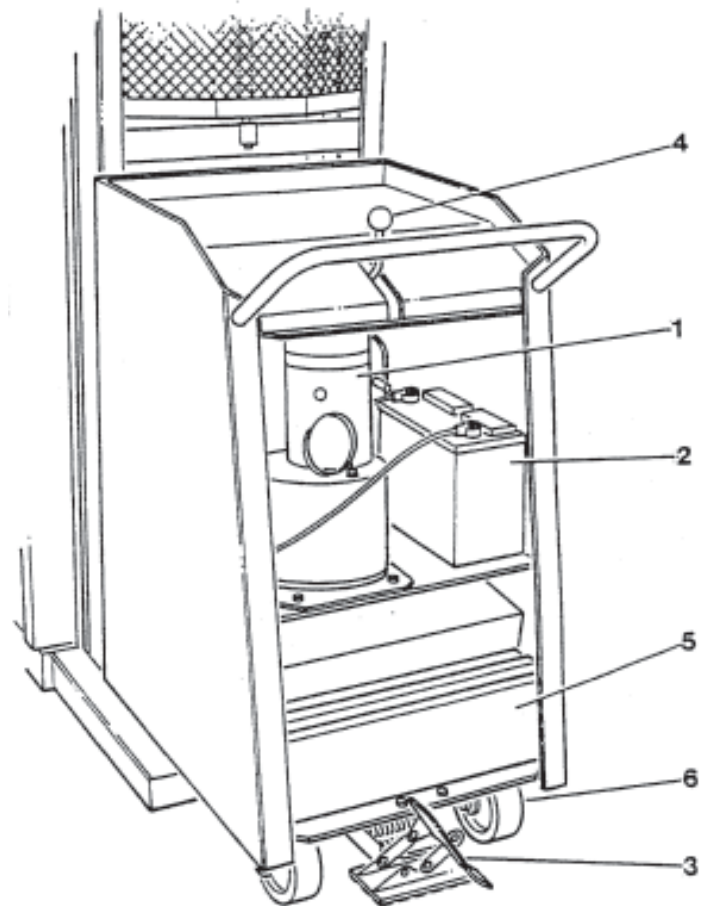

OPERATOR INSTRUCTIONS

PRESTO COUNTERWEIGHT LIFT

**CAUTION: THIS LIFT REQUIRES COUNTERWEIGHT
(BALLAST) BEFORE OPERATION**

WARNINGS

- DO NOT** use this lift until you have been trained and authorized to do so.
- DO NOT** operate until you have read all warnings and instructions.
- DO NOT** exceed load center or load weight capacities (check capacity plate).
- DO NOT** operate until you have checked the conditions of the truck: lift systems, forks, chains, cables and floor lock.
- DO NOT** use if any part is damaged, worn or not working properly.
- DO NOT** use on ramps or inclines. Only smooth level surfaces.
- DO NOT** use for lifting or carrying people.
- DO NOT** handle unbalanced, unstable or loosely stacked loads.
- DO NOT** travel with forks or platform in an elevated position.
- DO NOT** handle high-unsecured loads that could fall backwards.
- DO NOT** allow people to stand or pass under forks or platform with or without load.
- DO NOT** operate when parts of anyone's body may be close to mast structure or any moving parts.
- DO NOT** drop loads on platform or forks.
- DO NOT** alter or modify this lift in any way.

A. PREPARATION FOR USE

This lift left our factory in perfect condition. It has been inspected and tested to assure performance standards have been met.

Visually inspect lift for damage. Check for attachments and accessories that may have been ordered. If there is any damage or missing parts, report it to your carrier and your Presto Lift dealer immediately.

Remove all metal/plastic bands, cardboard and other material used for shipping purposes.

Remove shipping (solid) plug from the lift cylinder and replace it with breather plug.

Check to see if chains are in place, the floor lock is in working order, and that the lift system is in working order. Inspect for oil leaks.
Connect battery cable. Check cables and wires on battery charger as well as battery.

B. COUNTERWEIGHT INSTRUCTIONS

CAUTION: Counterweight lifts will tip over if adequate counterweight (ballast) is not added to handle the weight of the load being lifted.

600 lbs. of counterweight (ballast) must be added for lifting 1000 lbs at a 13 inch load center. The recommended counterweight is plate steel: 1/2" thick x 12" wide x 12-1/2" long.

FOR REDUCED (LIGHTER) LOAD CAPACITY

<i>Load Weight</i>	<i>Counterweight (Ballast) Minimum lbs. required</i>
0 - 199 lbs. @ 13" L.C.	Use 150 lbs. of C.W.
200 - 399 lbs. @ 13" L.C.	Use 300 lbs. of C.W.
400 - 599 lbs. @ 13" L.C.	Use 400 lbs. of C.W.
600 - 799 lbs. @ 13" L.C.	Use 500 lbs. of C.W.
800 - 1000 lbs. @ 13" L.C.	Use 600 lbs. of C.W.

IMPORTANT: If less than 600 lbs. of counterweight is used, the reduced (lighter) load weight capacity must be noted on lift.

Before handling loads -- test for lifting, lowering, traveling and cornering.

If lift does not appear to be operating, do not use until it has been checked and repaired by a qualified maintenance person.

C. CAPACITY

Three factors are critical to the capacity of counterweight lifts: load weight, load center and the counterweight (ballast).

- 1. Load Weight:** Presto counterweight lifts have a load weight capacity of 1000 lbs. with 600 lbs. of counterweight. Any reduction in the amount of counterweight lowers the load weight capacity.
- 2. Load Center:** Presto counterweight lifts have a 13-load center. The center of an evenly distributed load should not exceed 13 inches measured from the back of the forks. Overall length of load should not exceed 26 inches.
- 3. Counterweight (ballast):** Proper counterweight must be added to handle the weight of the load being lifted. 600 lbs. is required for lifting 1000 lbs. at 13" load center. If less than 600 lbs. of counterweight is used, the lighter load weight capacity must be noted on the lift.

- 13" Load Center is measured horizontally from back of forks.
- Center of evenly distributed load should not exceed 13 inches and overall length should not exceed 26 inches.

WARNING: DO NOT OVERLOAD

Counterbalanced lifts will tip over if load weight, load center or counterweight (ballast) instructions are not followed.

D. OPERATIONS

PRECAUTIONS:

AUTHORIZED OPERATORS SHOULD READ AND UNDERSTAND ALL INSTRUCTIONS, PRECAUTIONS AND WARNINGS. IMPROPER USE OF THIS LIFT TRUCK COULD RESULT IN INJURY AND/OR DAMAGE TO LOAD AND EQUIPMENT.

Inspect the lift for damaged or worn parts. Do not use if not in safe operating condition.

Use lift on hard level surfaces only.

Make sure load is evenly distributed (not loose or unstable), and is as far back on forks as possible. Do not pick up loads on tips of forks or edge of platform.

Adjust forks to the maximum practical width. Pick up loads on both forks (not one).

Do not overload: Check load center and load weight capacities on manufacturer's name plate.

Make sure travel and work area is clear of obstructions.

Check overhead clearance before lifting loads or transporting.

Make sure floor lock pad is secured to floor before lifting, lowering or using as a workstation.

Brace or block lift when sliding loads on or off platform or forks.

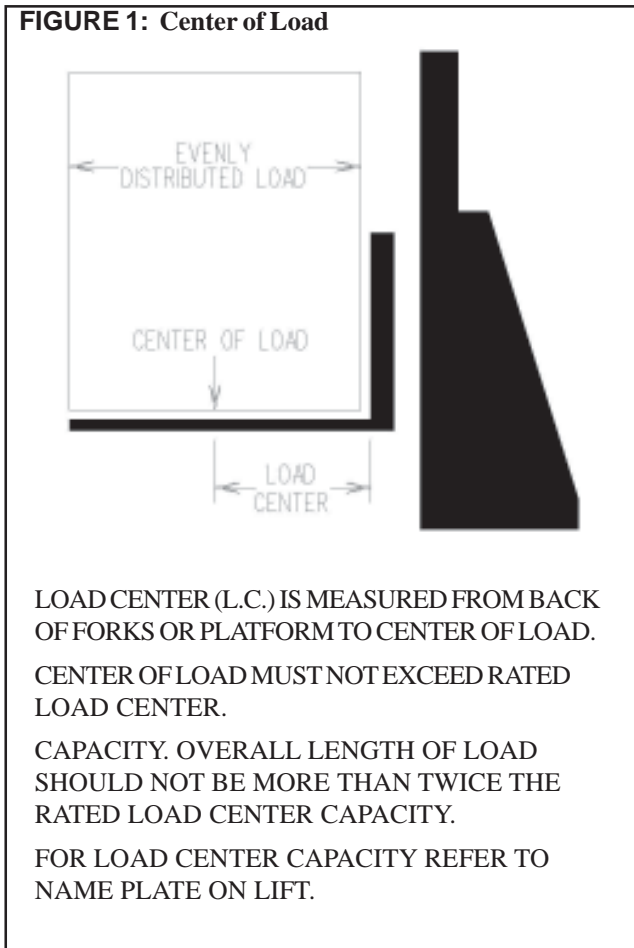

Ordering Replacement Parts

Presto Lifts has carefully chosen the components in your unit to be the best available for the purpose. Replacement parts should be identical to the original equipment. Presto Lifts will not be responsible for equipment failures resulting from the use of incorrect replacement parts or from unauthorized modifications to the unit.

Presto Lifts can supply all replacement parts for your lift. With your order, please include the model number and the serial number of the unit. You can find these numbers on the name plate. This plate is located within the cabinet, or the angle iron cylinder cross support.

To order replacement parts, please call the Presto Parts Department. Parts are shipped subject to the following terms:

- FOB factory
- Returns only with the approval of our parts department.
- Credit cards preferred (except parts covered by warranty).
- Freight collect for truck (except parts covered by warranty).
- Freight - prepaid and invoice for small parcel shipments (except parts covered by warranty).

Parts replaced under warranty are on a “charge-credit” basis. We will invoice you when we ship the replacement part, then credit you when you return the worn or damaged part.

Presto Lifts Parts Department

P.O. Box 1380, Portland, ME 04104-1380

Telephone: 800-343-9322

FAX: 888-788-6496

Email: Service@PrestoLifts.com

www.PrestoLifts.com

RESTOCKING POLICY

Presto Lift, Inc.'s goal is for you to be satisfied with your order. Merchandise may be returned, but returns will be subject to a restocking fee to cover the costs Presto Lift, Inc. incurs which include but are not limited to handling, storage of the units, etc. Presto Lift, Inc. will issue refurbishing costs where end-user wear is apparent. We would prefer to not charge for these costs but find it necessary any apologize for any inconvenience. Please review the RETURN MATERIALS AUTHORIZATION (RMA) PROCEDURES.

PARTS

Standard parts may be returned with a 20% restocking fee. Modified or custom-engineered parts are not returnable. Unfortunately, due to potentially concealed damage, all sales of electrical assemblies are final.

QUALITY ISSUES

Should you feel there is a quality problem, please contact the seller to ask questions and gather information on how to rectify the issue. Presto Lift Inc. reserves the right to determine potential credits, as a result of factory defects, based on its inspection of the merchandise.

GENERAL

All products shipped from our factory have passed Quality Assurance inspection and testing. The carrier of choice has signed for, and accepted the product in new working condition. The customer should inspect to ensure it is not received damaged, has no concealed damage or is not incomplete. Parts orders are determined to be complete based upon Presto Lift, Inc. inspection sheets and carrier shipping weights.

RETURN MATERIALS AUTHORIZATION (RMA) PROCEDURES

Although Presto Lift, Inc. is not legally obligated to issue a credit for any merchandise, the RETURN MATERIALS AUTHORIZATION (RMA) PROCEDURE is provided as a courtesy to our customers in the event they do not receive what they wanted.

If a customer wishes to return a Presto Lift, Inc. product, the first step in the process is to request an RMA number from Presto Lift, Inc.'s Customer Service Department. This request must be made on or before the thirtieth (30th) calendar day following the date of Presto Lift, Inc.'s invoice for the merchandise being returned.

The RMA number must appear on the outside of any packaging material for a return to be accepted and processed by Presto Lift, Inc. Customers shipping returns back to Presto Lift, Inc. from the Continental US, Canada and Mexico have fourteen (14) days from the effective date of the RMA to have the merchandise arrive freight prepaid at Presto Lift, Inc. Returns from locations other than the Continental US, Canada and Mexico must be shipped within the thirty (30) day period to arrive Free On Board (FOB) at Presto Lift Inc as soon as practical. If a customer believes Presto Lift, Inc.'s merchandise is defective, freight will be reimbursed to the original "Bill To" on the invoice if Presto Lift Inc. finds that the merchandise is defective.

Please remember that merchandise with RMA's coming back to Presto Lift Inc. from the Continental US, Canada and Mexico will not be accepted by Presto Lift Inc. if the returned goods do not arrive freight prepaid at Presto Lift Inc. within the thirty (30) day effective period.

All credits issued are less restocking fees as applicable, plus any assessed outbound/inbound in-transit damages.

Return addresses: please refer to your RMA for the address to which your product should be returned.

Presto Lift Inc.
715 Highway 77
Manila, Arkansas 72442

Telephone: 800-343-9322
Fax: 888-788-6496

Presto Lifts Limited Warranty Policy

Presto Lifts warrants all of its products against defects in the welded structural frame and, if applicable, scissor legs from faulty material and workmanship for a period of five (5) years from the date of invoice.

A lifetime limited warranty is provided for the Airstroke Actuator™ in all pneumatic lifts against any defect due to faulty material or workmanship.

All batteries are covered under a separate limited warranty from the battery manufacturer for a period of one year from the date of invoice.

All other components have a limited warranty against defects in faulty material and workmanship for a two (2) year period from the date of invoice date of invoice and 30 day limited warranty on labor. Please note that prior authorization from Presto Lifts is required on all warranty work.

There are no implied warranties of any kind, more specifically, there are no warranties of merchantability or fitness for any particular purpose. Presto Lifts' sole warranty shall be as set forth in this limited warranty.

Presto Lifts will elect to repair or replace a defective component without charge, if any components should become defective within the limited warranty period. Proof of purchase is required for warranty. The charge for shipping the defective component is the responsibility of the buyer and must be accompanied with an RMA number. The shipping charge to return the component to the buyer is the responsibility of Presto Lifts, Inc.

This limited warranty does not cover labor expense for removal or reinstallation of components after thirty days. This limited warranty shall not cover, among other things: damages resulting from foreign matter or water, failure to provide reasonable and necessary maintenance, and if applicable, use of product while charger is plugged into an AC outlet, or failure to follow operating instructions. The limited warranty is not valid for damage resulting from negligence, accident, unreasonable use, abuse or misuse, exceeding data plate capacities or altering the product without Presto Lifts authorization.

Presto Lifts expressly disclaims and excludes any liability for consequential, incidental, indirect or punitive damages or financial loss to people or property resulting from any breach of warranty or the operation or failure of this product.

Presto Lifts makes no representation that this product complies with local, state, or federal safety/product standards codes. Should this product fail to comply in any way with those codes, it shall not be considered a defect of materials or workmanship. Presto Lifts shall not be held liable for any damages resulting from noncompliance. It is the dealer's responsibility to exercise this limited warranty. This limited warranty is provided to the original purchaser (defined as the original end user) and is nontransferable. This constitutes the complete and final agreement involving Presto Lifts and limited warranty obligations for products.

Go Presto LIFTS™

MANY NEEDS REQUIRE
MANY OPTIONS...



Lift
Stik



Post
Tables



Double Lift
Table



Lift
Table



Portable
Lift



P3



Counterweight
Stacker



Pallet
Jack



Pneumatic
Lift/Tilt

Call Presto Sales
for stock or customized lift inquiries at

800-343-9322

Email: sales@prestolifts.com



Portable
Tilter



Floor
Level
Lift



Stacker