

Model **SB** Horizontal Belt Conveyor (Slider Bed)

SLIDER BED

The Model SB is a slider bed conveyor designed with channel frames and bolt in pans. Frame design makes it ideal for matching up with roller bed conveyors.



Conveyor shown with optional floor supports



- ★ 14 Belt Widths
- ★ Center Drive
- ★ Reversible
- ★ System Ends
- ★ Pop-Out Roller
- ★ Adjustable MS-Type Floor Supports Available

SIZE TO ORDER Overall Length "A" 4" Dia. Pulley	Bed Length "L"	Belt Width							SIZE TO ORDER Overall Length "A" 6" Dia. Pulley	Belt Width							
		10"	12"	14"	16"	18"	20"	22"		24"	28"	30"	34"	36"	42"	48"	
		Between Rail Width	13"	15"	17"	19"	21"	23"		25"	27"	31"	33"	37"	39"	45"	51"
Overall Frame Width		16"	18"	20"	22"	24"	26"	28"	Overall Frame Width		30"	34"	36"	40"	42"	48"	54"
12'	10'	561	593	625	657	689	721	753	12'	791	865	940	1014	1088	1162	1237	
17'	15'	660	696	732	768	804	840	876	17'	919	1002	1085	1167	1250	1333	1415	
22'	20'	760	800	840	880	920	960	1000	22'	1047	1138	1230	1321	1412	1503	1594	
27'	25'	859	903	947	991	1035	1079	1123	27'	1175	1275	1375	1474	1574	1673	1773	
32'	30'	959	1007	1054	1102	1150	1198	1246	32'	1304	1412	1520	1627	1735	1844	1952	
37'	35'	1058	1110	1162	1214	1266	1317	1369	37'	1432	1548	1665	1781	1897	2014	2130	
42'	40'	1158	1213	1269	1325	1381	1437	1492	42'	1560	1685	1810	1934	2059	2184	2309	
47'	45'	1257	1317	1377	1436	1496	1556	1616	47'	1688	1821	1955	2088	2221	2355	2488	
52'	50'	1357	1420	1484	1548	1612	1675	1739	52'	1816	1958	2100	2241	2383	2525	2667	
57'	55'	1456	1524	1592	1659	1727	1794	1862	57'	1944	2094	2245	2395	2545	2695	2845	
62'	60'	1556	1627	1699	1771	1842	1914	1985	62'	2072	2231	2390	2548	2707	2865	3024	
67'	65'	1655	1731	1806	1882	1957	2033	2109	67'	2200	2367	2535	2702	2869	3036	3203	
72'	70'	1755	1834	1914	1993	2073	2152	2232	72'	2328	2504	2680	2855	3031	3206	3382	
77'	75'	1854	1938	2021	2105	2188	2272	2355	77'	2456	2640	2825	3009	3193	3376	3560	
82'	80'	1954	2041	2129	2216	2303	2391	2478	82'	2585	2777	2970	3162	3354	3547	3739	
87'	85'	2053	2145	2236	2327	2419	2510	2601	87'	2713	2914	3115	3315	3516	3717	3918	
92'	90'	2153	2248	2343	2439	2534	2629	2725	92'	2841	3050	3260	3469	3678	3887	4097	
97'	95'	2252	2352	2451	2550	2649	2749	2848	97'	2969	3187	3405	3622	3840	4058	4275	
102'	100'	2352	2455	2558	2662	2765	2868	2971	102'	3097	3323	3550	3776	4002	4228	4454	

All weights in catalog are conveyor weights only. Accessories, crating, etc., are not included.

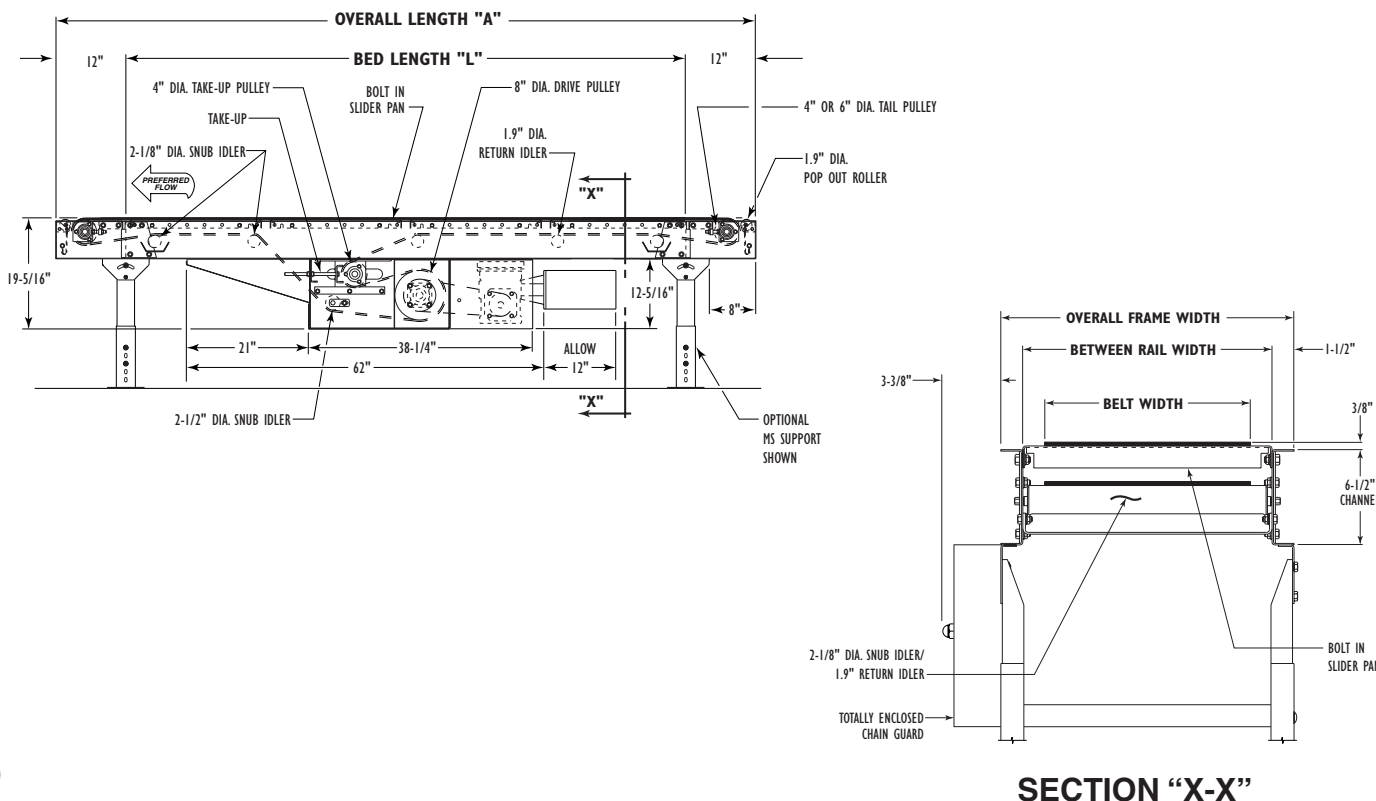

Standard Specifications

BELT—Ultimate 140 BOS—Nitrile, impregnated belt with one side brushed.

BED—12 ga. galvanized slider pan mounted in 6-1/2 in. x 12 ga. powder painted formed steel channel frame bolted together with splice plates.

CENTER DRIVE—Provides 16 in. of belt take-up. Minimum elevation—19-1/2 in. Specify location. **Minimum OAL without modification**—120 in. Chain guard located on left hand side.

DRIVE PULLEY—8 in. dia. with 1-3/16 in. dia. shaft at bearings, machine crowned and fully lagged.

TAIL PULLEY—4 in. dia. with 1 in. dia. shaft at bearings or 6 in. dia. with 1-3/16 in. dia. shaft at bearings, machine crowned. See chart on Page 10.

SNUB IDLER—Adjustable 2-1/8 in. dia. pre-lubricated ball bearings. Guards included.

RETURN IDLER—Adjustable 1.9 in. dia. pre-lubricated ball bearings.

TAKE-UP—Take-up in center drive provides 16 in. of belt take-up.

BEARINGS—Sealed, pre-lubricated, self-aligning, ball bearings on drive and tail pulleys.

SPEED REDUCTION—Sealed worm gear C-Face speed reducer. No. 50 roller chain to drive pulley.

MOTOR—1/2 HP—230/460V—3 Ph.—60 Hz. Totally Enclosed C-Face.

BELT SPEED—Constant 65 FPM.

CAPACITY—Maximum load per linear foot of conveyor 100 lbs. NOT TO EXCEED capacity in charts.

FLOOR SUPPORTS—Now supplied as optional equipment.

8" DIA. DRIVE PULLEY LIVE LOAD CAPACITY @ 65 FPM			
HP	BELT WIDTHS TO	LENGTHS UP TO	
		52'	102'
		DISTRIBUTED LOAD (LBS.)	
1/2	14"	420	370
	24"	380	310
	36"	310	220
	48"	270	140
3/4	14"	670	620
	24"	640	570
	36"	570	470
	48"	520	390
1	14"	920	870
	24"	890	820
	36"	820	720
	48"	770	770
1-1/2	14"	1420	1370
	24"	1390	1320
	36"	1320	1230
	48"	1370	1140
2	14"	1920	1870
	24"	1890	1820
	36"	1820	1730
	48"	1770	1650

Optional Equipment

FLOOR SUPPORTS—MS Type floor supports are available with a wide range of adjustment. Specify top of belt or roller elevation. One support required at every bed joint and ends of conveyor. Holes in feet for lagging to floor. Knee braces recommended above MS-6 support.

***BELT**—Black or white Polymate 100 RMP-COS (cover one side), Black Trackmate 447 Roughtop with PVC cover, Black Trackmate 533 COS-PVC, Tan Glidetop.

***BELT SPEED**—Other constant and variable speeds. V-belt drive supplied on speeds under 17 FPM.

END DRIVE—8 in. end drive mounted on end of unit.

LOW ELEVATION SIDE MOUNTED CENTER DRIVE—Motor reducer unit mounted to side of conveyor. Minimum elevation 16-1/2 in.

V-BELT DRIVE—V-Belt supplied between motor and reducer. Minimum overall drive width 14 in.

O-RING DRIVE CHAIN—With sealed in lubricant (Recommended for applications that do not permit regular lubrication).

GUARD RAILS—Continuous adjustable channel, fixed channel, type A & B angle. Fixed Channel overlapping, one direction. Fixed Channel non-overlapping, reversing. See Accessory section.

PULLEYS—6 in. tail pulley with 1-3/16 in. dia. shaft at bearings in place of 4 in. when not furnished as standard.

CASTERS—See Accessory section.

POLY-TIER SUPPORTS—36 in. to 120 in. support heights in 6 in. increments. Knee braces supplied.

CEILING HANGERS—5/8 in. dia. x 8 ft. long unplated rods fully threaded. Other lengths and galvanized rods available.

MOTORS—Energy efficient, single phase, other characteristics. 2 HP maximum.

ELECTRICAL CONTROLS—One direction manual start switch, reverse drum switch, non-reversing and reversible magnetic starters, push button stations. AC variable frequency drive.

***NOTE:** Capacity affected with these options.