

Model 138-NSP Live Roller Conveyor

The Model 138-NSP Live Roller Spool Conveyor is a general transport conveyor with the capabilities of accumulating products with back-pressure. Quiet operation, versatile design, easy installation and maintenance make the 138-NSP conveyor a valuable component in operations requiring high performance with minimal downtime.



Conveyor shown with optional floor supports

- ★ 4 Bed Widths
- ★ Reversible
- ★ Adjustable LS-Type Floor Supports Available

LIVE ROLLER

SIZE TO ORDER Overall Length "A"	Between Rail Width	10"	13"	16"	22"
	Overall Frame Width	12"	15"	18"	24"
5'	WEIGHTS (Lbs.) Based on 3" Roller Centers	190	198	206	230
10'		296	313	324	360
15'		402	430	442	493
20'		507	544	559	627
25'		612	660	677	759
30'		719	775	796	893
35'		824	890	913	1026
40'		929	1005	1031	1158
45'		1035	1119	1149	1291
50'		1141	1236	1268	1425
55'		1247	1351	1385	1557
60'		1352	1465	1503	1690
65'		1458	1580	1620	1823
70'		1564	1696	1739	1956
75'		1669	1810	1857	2089
80'		1775	1925	1975	2222
85'		1880	2040	2092	2354
90'		1987	2156	2210	2488
95'		2092	2271	2328	2621
100'	2198	2386	2446	2753	

All weights in catalog are conveyor weights only. Accessories, crating, etc., are not included.

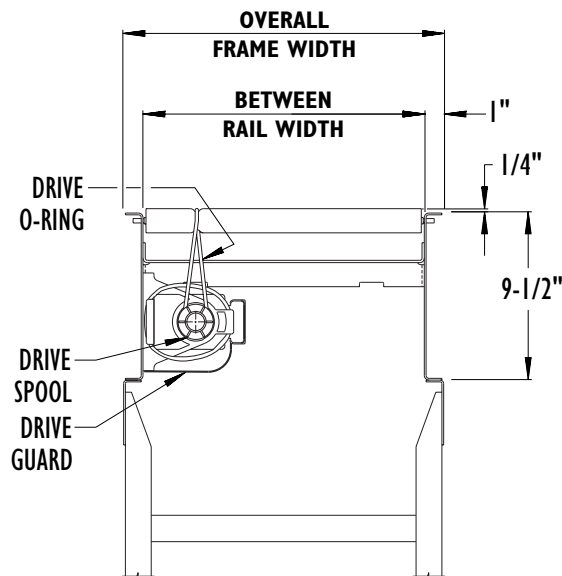

VIEW "X-X"

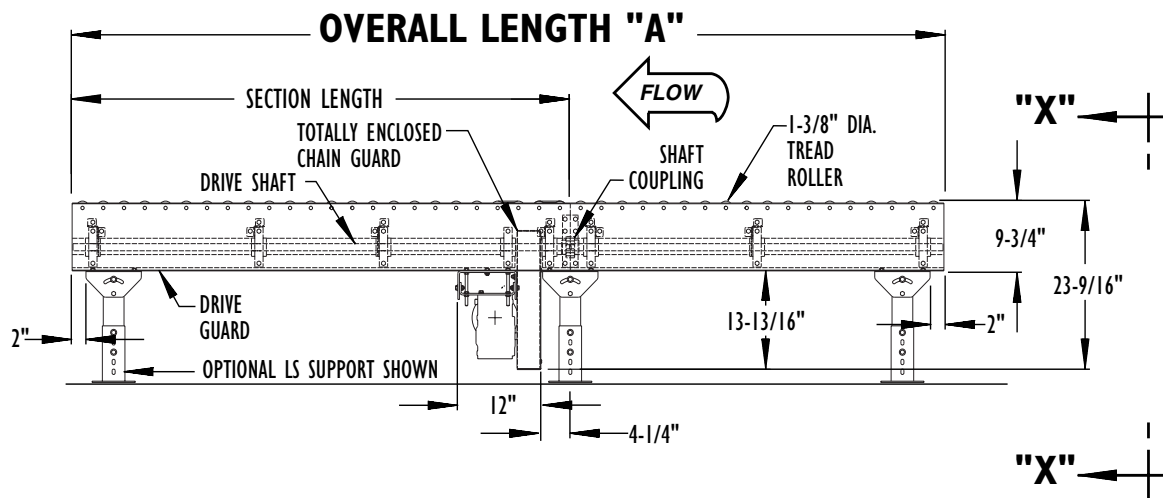

Standard Specifications

BED—Roller bed with 1-3/8 in. dia. roller x 18 ga. galvanized tube spaced every 3 in. Mounted in 9-1/2 in. x 12 ga. powder painted formed steel channel frame bolted together with splice plates.

CROSS BRACING—Rods with turnbuckles are fastened to underside of bed to provide proper alignment of bed rollers and insure correct product tracking. Supplied on every other section, 30 ft. bed lengths and over.

DRIVE—Mounted underneath, placed near center of conveyor. **NOTE: On Conveyors less than 24 in. OAW, motor extends beyond frame.** Chain guard located on left hand side.

DRIVE SHAFT—1 in. dia. steel shaft extends full length of conveyor. Chain coupling at bed joints. Located on left hand side.

DRIVE SPOOLS—2 in. dia. Delrin spool held in place on drive shaft with spool spacers.

DRIVE GUARD—Underside of drive shaft with spools and drive o-rings guarded full length of conveyor.

DRIVE O-RINGS—1/8 in. dia. polyurethane o-ring from drive spool to tread rollers.

BEARINGS—Sealed, pre-lubricated, self-aligning, ball bearings with eccentric lock collar on drive shaft. Pre-lubricated ball bearings in tread rollers.

SPEED REDUCTION—Sealed worm gear C-Face speed reducer. No. 50 roller chain to drive shaft.

MOTOR—1/2 HP—230/460V—3 Ph.—60 Hz. Totally Enclosed C-Face.

CONVEYING SPEED—Constant 65 FPM.

CAPACITY—Maximum load per powered roller 10 lbs. **NOTE: Maximum load capacity will be less for products with soft or irregular bottoms.** Total load NOT TO EXCEED capacity in chart.

FLOOR SUPPORTS—Now supplied as optional equipment.

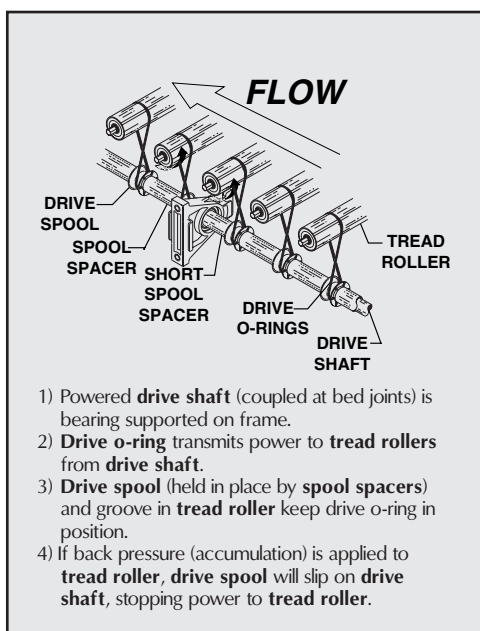

LOAD CAPACITY CHART @ 65 FPM			
HP	OVERALL FRAME WIDTH		
	12" TO 24"		
	TOTAL LOAD (LBS.)		
	UP TO 60'	UP TO 90'	UP TO 120'
1/2	1550	580	—
3/4	*2400	2300	1360
1	—	*3600	3100
1 1/2	—	—	*4800

*Limited to 10 lbs. per roller

NOTE: Capacity in chart based on 3" roller centers, with all rollers powered.

MOTOR SELECTION CHART		
FPM	30-44	45-90
HP (MAX)	1	1-1/2

If the required horsepower exceeds the maximum horsepower shown in the chart, more than one drive is required

Optional Equipment

FLOOR SUPPORTS—LS Type floor supports are available with a wide range of adjustment. Specify top of belt or roller elevation. One support required at every bed joint and ends of conveyor. Holes in feet for lagging to floor. Knee braces recommended above LS-6 support.

CONVEYING SPEED—Other constant and variable speeds from 30 to 90 FPM. Over 90 FPM contact factory. **Capacity affected with speed change.**

O-RING DRIVE CHAIN—With sealed in lubricant (Recommended for applications that do not permit regular lubrication).

CROSSOVER—Separate section relocates drive shaft from one side of conveyor to the other. 1-1/2" Roller Centers—Minimum elevation 13-3/8 in. for 10 in. BR and 12-3/8 in. for 13 through 22 in. BR.

ONE DIRECTION O-RING TRANSFER—See Conveyor Accessories.

REVERSING O-RING TRANSFER—See Conveyor Accessories.

PACKAGE STOPS—Blade, roller or pin type stops available, contact factory.

GUARD RAILS—Continuous adjustable channel, fixed channel or Type A & B angle. **NOTE: If product comes in contact with guard rails, product flow will be affected.** Fixed channel overlapping, one direction. Fixed channel non-overlapping, reversing.

ROLLER CENTERS—Tread rollers spaced every 1-1/2 in. **NOTE: Capacity changes with roller center changes. Inquire for capacity information.**

POLY-TIER SUPPORTS—36 in. to 120 in. support heights in 6 in. increments. Knee braces supplied.

CEILING HANGERS—5/8 in. dia. x 8 ft. long unplated rods fully threaded. Other lengths and galvanized rods available.

MOTORS—Energy efficient, single phase other characteristics. 1-1/2 HP maximum.

ELECTRICAL CONTROLS—Non-reversing or reversible magnetic starters and push-button stations. AC variable frequency drive.