

Model R Aluminum Portable Folding Belt Conveyor

The Model R, besides being extremely convenient (it can be folded in half), is also extremely versatile. For example, its conveying uses include: truck, loft or freight car, floor-to-floor, stairway, as well as its use as a portable booster with a wheel or roller conveyor. It is also suitable for bag handling, bag and carton stacking, and moving cartons, cases, and boxes.



1 Week Availability

- ★ Folding Aluminum Bed
- ★ Roughtop Belt
- ★ Electrical Controls
- ★ Reversible

ADJUSTMENT CHART FOR 10' TO 21' LONG UNITS

SIZE TO ORDER	Angle of Incline	D = 7" Less Roller Carriage			SIZE TO ORDER	Angle of Incline	D = 18" With Roller Carriage			SIZE TO ORDER	Angle of Incline	D = 31" With Roller Carriage		
		"E"	"F"	"G"			"E"	"F"	"G"			"E"	"F"	"G"
		10'	11°	2'-5"			9'-10"	1'-8"	10'			3°	2'-0"	10'-0"
	25°	4'-6"	9'-1"	1'-2"		25°	5'-6"	9'-2"	1'-5"		25°	6'-6"	9'-1"	2'-0"
	30°	5'-3"	8'-9"	0'-11"		30°	6'-3"	8'-7"	1'-3"		27°	6'-11"	8'-11"	2'-0"
	43°	7'-0"	7'-6"	0'-1"		36°	7'-1"	8'-2"	1'-0"		-	-	-	-
11 1/2'	11°	2'-9"	11'-5"	3'-3"	11 1/2'	3°	2'-1"	11'-7"	3'-5"	11 1/2'	0°	2'-7"	11'-7"	3'-9"
	25°	5'-3"	10'-7"	2'-7"		25°	6'-3"	10'-7"	2'-10"		25°	7'-3"	10'-7"	3'-6"
	30°	6'-1"	10'-2"	2'-4"		30°	7'-1"	10'-2"	2'-8"		27°	7'-8"	10'-5"	3'-5"
	43°	8'-1"	8'-8"	1'-4"		36°	8'-1"	9'-6"	2'-4"		-	-	-	-
13'	11°	3'-0"	12'-11"	2'-10"	13'	3°	2'-2"	13'-0"	3'-0"	13'	0°	2'-7"	13'-1"	3'-3"
	25°	5'-10"	11'-11"	2'-5"		25°	6'-11"	12'-0"	2'-11"		25°	7'-11"	11'-11"	4'-0"
	30°	6'-10"	11'-5"	2'-3"		30°	7'-10"	11'-5"	2'-10"		27°	8'-4"	11'-9"	4'-0"
	43°	9'-2"	9'-9"	1'-8"		36°	9'-0"	10'-9"	2'-10"		-	-	-	-
15'	11°	3'-5"	14'-10"	4'-10"	15'	3°	2'-3"	15'-0"	5'-0"	15'	0°	2'-7"	15'-1"	5'-3"
	25°	6'-9"	13'-9"	4'-2"		25°	7'-9"	13'-9"	4'-8"		25°	8'-9"	13'-9"	5'-9"
	30°	7'-10"	13'-2"	3'-11"		30°	8'-10"	13'-2"	4'-7"		27°	9'-3"	13'-6"	5'-9"
	43°	10'-6"	11'-3"	3'-2"		36°	10'-2"	12'-4"	4'-5"		-	-	-	-
17'	10°	3'-6"	16'-10"	5'-9"	17'	3°	2'-5"	17'-0"	6'-0"	17'	0°	2'-7"	17'-1"	6'-3"
	25°	7'-6"	15'-6"	5'-3"		25°	8'-7"	15'-6"	5'-11"		25°	9'-7"	15'-6"	7'-5"
	30°	8'-10"	14'-10"	5'-1"		30°	9'-10"	14'-10"	5'-10"		-	-	-	-
	38°	10'-9"	13'-7"	4'-9"		36°	11'-3"	13'-11"	5'-8"		-	-	-	-
19'	10°	3'-9"	18'-10"	7'-9"	19'	3°	2'-6"	19'-0"	8'-0"	19'	0°	2'-7"	19'-1"	8'-3"
	25°	8'-5"	17'-3"	7'-1"		25°	9'-5"	17'-4"	7'-9"		23°	9'-11"	17'-7"	9'-0"
	30°	9'-10"	16'-7"	6'-10"		30°	10'-10"	16'-7"	7'-8"		-	-	-	-
	38°	12'-0"	15'-2"	6'-3"		-	-	-	-		-	-	-	-
21'	8°	3'-6"	20'-11"	9'-0"	21'	2°	2'-3"	21'-0"	9'-3"	21'	0°	2'-7"	21'-1"	9'-6"
	25°	9'-3"	19'-1"	8'-4"		25°	10'-3"	19'-2"	9'-2"		23°	10'-8"	19'-5"	10'-7"
	30°	10'-9"	18'-4"	8'-1"		30°	11'-10"	18'-3"	9'-1"		-	-	-	-
	37°	12'-11"	17'-0"	7'-10"		-	-	-	-		-	-	-	-

SIZE TO ORDER	Motor H.P.	Overall Length "A"	"B"	"C"	Weights (Lbs.)
10'	1/2	10'-1"	5'-0 1/2"	5'-0 1/2"	175
11-1/2'	1/2	11'-7"	6'-6 1/2"	5'-0 1/2"	190
13'	1/2	13'-1"	6'-6 1/2"	6'-6 1/2"	205
15'	1/2	15'-1"	8'-6 1/2"	6'-6 1/2"	225
17'	1/2	17'-1"	8'-6 1/2"	8'-6 1/2"	245
19'	3/4	19'-1"	10'-6 1/2"	8'-6 1/2"	270
21'	3/4	21'-1"	10'-6 1/2"	10'-6 1/2"	285

All weights in catalog are conveyor weights only. Accessories, crating, etc., are not included.

P O R T A B L E S

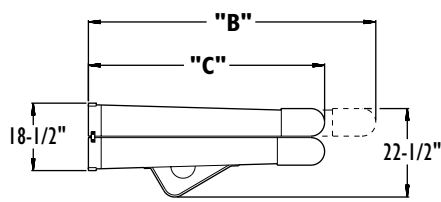
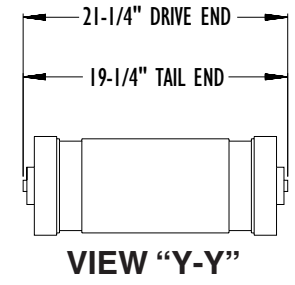
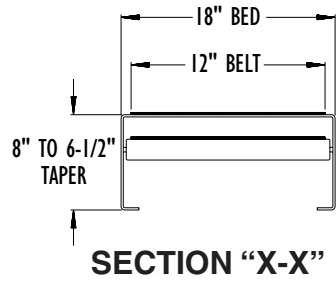
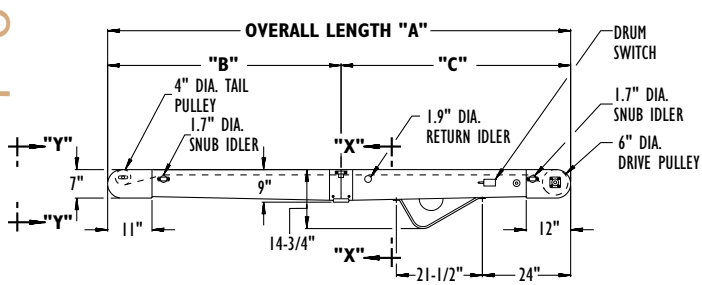

FOLDED MODEL "R"

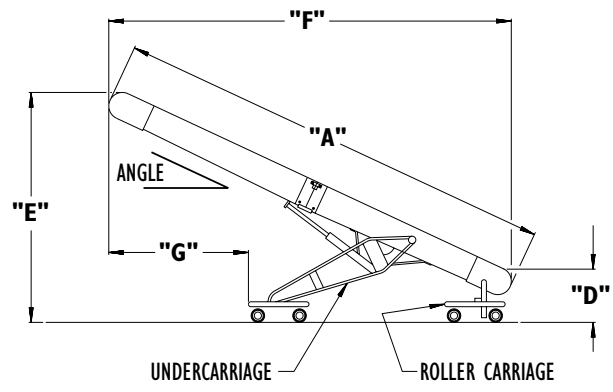

Standard Specifications

BELT—12 in. wide Black Trackmate 447 Roughtop with PVC cover. Clipper unibar lacing.

BED—18 in. wide x .080 aluminum, 6061-T6 heat treated, reinforced.

DRIVE PULLEY—6 in. dia. with 3/4 in. dia. shaft. Machine crowned and fully lagged.

TAIL PULLEY—4 in. dia. with 1 in. dia. shaft at bearings, machine crowned.

SNUB IDLER—Adjustable 1.7 in. dia. pre-lubricated ball bearings.

RETURN IDLER—Adjustable 1.9 in. dia. pre-lubricated ball bearings.

TAKE-UP—Take-ups provided at tail pulley. Provides 4 in. of belt take-up.

BEARINGS—Sealed, pre-lubricated ball bearings on drive and tail pulleys.

SPEED REDUCTION—4-step jackshaft V-belt and No. 40 roller chain.

MOTOR—For HP see chart, 115/230V—1 Ph. 60 Hz. totally enclosed and wired for 115 volt.

ELECTRICAL CONTROLS—Reversing drum switch with power cord and plug mounted on side shown on drawing. Specify if other side desired.

BELT SPEED—Constant 65 FPM.

CAPACITY—300 lbs. total distributed load, 150 lbs. unit load at 65 FPM.



GRAVITY CONVEYOR BRACKET



ROLLER CARRIAGE AND UNDERCARRIAGE



LOWER POWERED FEEDER

Optional Equipment

CLEATED BELT—Two 1-1/2 in. dia. x 1 in. high hardwood cleats, fastened to belt by 5/16 in. elevator bolts spaced every 60 in. Requires gear reducer drive and spooled idlers.

BELT SPEED—Other constant and variable speeds. Requires gear reducer drive. **NOTE: Capacity affected with speed change.**

RUBBER WHEELS—Two 6 in. dia. x 2 in. wide with 5/8 in. dia. shaft.

STAND WITH RUBBER WHEELS—6 in. dia. x 2 in. wide wheels (with locks) mounted on adjustable tubular stand, 17 in. to 36 in. top of belt.

UNDERCARRIAGE—25 in. wide tubular steel frame with hydraulic adjustment mounted on support with 4 in. dia. steel swivel casters. See drawing and adjustment chart.

ROLLER CARRIAGE—25 in. wide tubular steel support with 4 in. dia. steel swivel casters. See drawing and adjustment chart.

FLOOR SUPPORTS—Adjustable steel channel with knee braces. RSR type.

GRAVITY CONVEYOR BRACKET—1/2 in. dia. rod for connecting wheel or roller conveyor.

LOWER GRAVITY FEEDER—2 ft. long x 18 in. wide (1-1/2SW-18-36) includes adjustable tubular support and gravity conveyor bracket.

UPPER GRAVITY FEEDER—2 ft. long x 18 in. wide (3SW-18-18) includes adjustable tubular support and gravity conveyor bracket.

LOWER POWERED FEEDER—Chain type driven from drive pulley. 2 ft. long belt feeder section includes adjustable tubular support and gravity conveyor bracket.

GUARD RAILS—Channel type, adjustable vertically and horizontally.

STAIRWAY WALL BRACKETS—Hinged brackets bolt to bed section and wall. Adjustable leg to rest on floor or step. Hook to hold conveyor close to wall when not in use.

TROUGHING ATTACHMENT—Flat steel supports under belt form trough for handling loose material. Hopper available. Not foldable with troughing attachment.

STAINLESS STEEL BED COVER—18 ga. stainless steel skin (for ice house application).

SELF-CLEANING DRIVE & TAIL PULLEYS—Crowned and ribbed to prevent clogging under belt.

GEAR REDUCER DRIVE—Sealed worm gear speed reducer driven by motor with V-belt. Drive is bolted to bottom of bed. (Standard motor support and guard not available.) Affects mounting of other options. Consult factory.

REMOTE SWITCH CONTROL—Rod running length of conveyor to operate reverse drum switch from both ends. Switch regularly furnished on side shown on drawing. Specify if required on other side.

MOTORS—Other characteristics. 3/4HP maximum.