

Model **TH** Trash Belt Conveyor

SLIDER BED



- ★ 7 Belt Widths
- ★ Center Drive
- ★ Adjustable MS-Type Floor Supports Available
- ★ Integral Side Guards
- ★ Underside Bed Cover Full Length

Designed to handle empty cardboard boxes and paper trash.

SIZE TO ORDER Overall Length "A"	Bed Length "L"	Belt Width	11 1/2"	17 1/2"	23 1/2"	29 1/2"	35 1/2"	41 1/2"	47 1/2"
		Between Rail Width	13"	19"	25"	31"	37"	43"	49"
		Overall Frame Width	16"	22"	28"	34"	40"	46"	52"
12'	10'	<b>WEIGHTS (Lbs.)</b>	732	867	1002	1137	1272	1408	1542
22'	20'		974	1152	1330	1508	1686	1865	2042
32'	30'		1216	1437	1658	1879	2100	2322	2542
42'	40'		1458	1722	1986	2250	2514	2779	3042
52'	50'		1700	2007	2314	2621	2928	3236	3542
62'	60'		1942	2292	2642	2992	3342	3693	4042
72'	70'		2184	2577	2970	3363	3756	4150	4542
82'	80'		2426	2862	3298	3734	4170	4607	5042
92'	90'		2668	3147	3626	4105	4584	5064	5542
102'	100'		2910	3432	3954	4476	4998	5521	6042
112'	110'		3152	3717	4282	4847	5412	5978	6542
122'	120'		3394	4002	4610	5218	5826	6435	7042
132'	130'		3636	4287	4938	5589	6240	6892	7542
142'	140'		3878	4572	5266	5960	6654	7349	8042
152'	150'	4120	4857	5594	6331	7068	7806	8542	

**ADD TO ABOVE WEIGHTS FOR THE FOLLOWING ACCESSORIES:**

• Underside take-up (manual) standard 76' - 150'	146	183	220	257	294	331	368
• Underside take-up (pneumatic) standard over 151'	214	261	308	355	402	449	496
• Noseover with 2 pulley hitch	138	172	206	240	274	308	342
• Other guard rails - pair - 6" high x 10' lg.	32	32	32	32	32	32	32
• Per 10' Int. section with support & belt	242	285	328	371	414	457	500

Above weights include 6" high guards, MS-6 supports, and 8" center drive. Accessories, crating, etc., are not included.

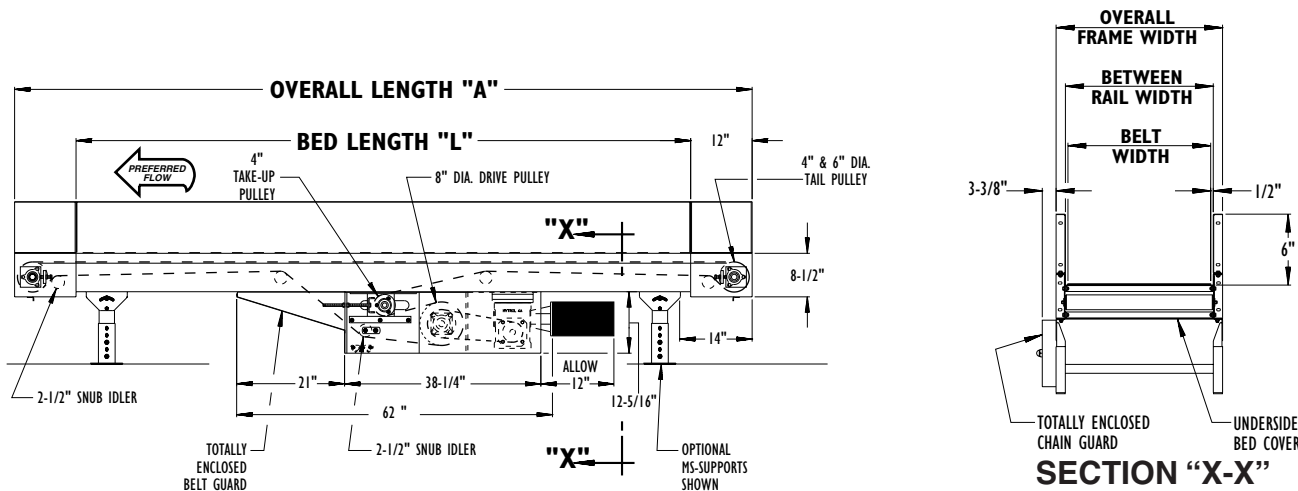

# Standard Specifications

**BELT**—Horizontal units: Ultimate 140 BOS—Nitrile, impregnated belt with one side brushed.

**BED**—14 ga. formed steel slider bed bolted between two 7-1/2 in. deep x 12 ga. formed steel side channels with 6 in. high guards. Standard 5, 6, 7, 8, 9, and 10 ft. long sections.

**CENTER DRIVE**—Minimum elevation—18-1/4 in. Can be placed on any section of conveyor length. **Minimum OAL without modification** 12 ft. 0 in. Chain guard located on left hand side.

**DRIVE PULLEY**—8 in. dia. with 1-3/16 in. dia. shaft at bearings, machine crowned and fully lagged.

**TAIL PULLEY**—4 in. dia. with 1 in. dia. shaft at bearings, machine crowned 13 in., 19 in., and 25 in. BR up to 150 ft. long. 6 in. dia. with 1-3/16 in. dia. shaft at bearings, machine crowned all other applications.

**SNUB IDLER**—Adjustable 2-1/8 in. dia. with HD pre-lubricated ball bearings.

**RETURN IDLER**—Adjustable 1.9 in. dia. pre-lubricated bearings.

**BEARINGS**—Sealed, pre-lubricated, self-aligning, cast-iron ball bearings on drive and tail pulleys.

**SPEED REDUCTION**—Sealed worm gear C-Face speed reducer. No. 50, 60 or 80 roller chain to drive pulley depending on speed and length.

**MOTOR**—3/4 HP—230/460V—3 Ph.—60 Hz. Totally Enclosed C-Face.

**BELT SPEED**—Constant 65 FPM.

**CAPACITY**—Maximum load per linear foot of conveyor 10 lbs.

**DUST PANS**—Solid 16 ga. underside dust covers held in place by 1/4 turn screws for easy removal.

**MANUAL UNDERSIDE TAKE-UP**—Provides 16 in. of belt take-up up to 150 ft..

**PNEUMATIC UNDERSIDE TAKE-UP**—Provides 60 in. of belt take-up for conveyors over 151 ft.

**FLOOR SUPPORTS**—Now supplied as optional equipment.

HP	OVERALL FRAME WIDTH TO	TOTAL LOAD LBS. OVERALL LENGTH			
		50'	75'	100'	150'
3/4	28"	365	285	210	—
	40"	275	160	—	—
	52"	185	—	—	—
1	28"	550	470	395	240
	40"	460	345	230	—
	52"	370	215	—	—
1 1/2	28"	905	840	760	610
	40"	825	710	595	365
	52"	735	585	430	125
2	28"	1275	1200	1125	970
	40"	1190	1075	960	730
	52"	1100	945	795	490

HP	OVERALL FRAME WIDTH TO	8 FEET LIFT				12 FEET LIFT			
		OVERALL LENGTH				OVERALL LENGTH			
		50'	75'	100'	150'	50'	75'	100'	150'
3/4	28"	250	210	160	—	210	190	150	—
	40"	180	100	—	—	150	—	—	—
	52"	110	—	—	—	—	—	—	—
1	28"	380	350	310	190	330	320	290	180
	40"	310	250	170	—	270	230	150	—
	52"	240	140	—	—	210	130	—	—
1 1/2	28"	640	640	620	520	560	590	570	490
	40"	570	540	470	300	500	490	440	280
	52"	500	430	330	—	440	390	300	—
2	28"	900	930	920	840	790	850	850	790
	40"	830	820	780	620	730	750	720	590
	52"	760	720	630	400	670	650	580	380

## Optional Equipment

**FLOOR SUPPORTS**—MS Type floor supports are available with a wide range of adjustment. Specify top of belt or roller elevation. One support required at every bed joint and ends of conveyor. Holes in feet for lagging to floor. Knee braces recommended above MS-6 support.

**BELT**—Inclined units: Black Trackmate 447 Roughtop with PVC cover.

**BELT SPEED**—Others constant or variable.

**END DRIVE**—8 in. end drive mounted on end of unit. 15-11/16 in. min. elevation.

**O-RING DRIVE CHAIN**—With sealed in lubricant (Recommended for applications that do not permit regular lubrication).

**NOSEOVER**—(10°, 12-1/2°, 15°) Fixed single nose for transition of product from incline to horizontal.

**TWO-PULLEY HITCH**—For transition of product from horizontal to incline (10°, 12-1/2°, 15°).

**POLY-TIER SUPPORTS**—36 in. to 120 in. support heights in 6 in. increments. Knee braces supplied.

**CEILING HANGERS**—5/8 in. dia. x 8 ft. long unplated rods fully threaded. Other lengths and galvanized rods available.

**MOTORS**—Energy efficient, single phase, other characteristics. 2 HP maximum.

**ELECTRICAL CONTROLS**—One direction manual start switch, non-reversing starters, push button stations. AC variable frequency drive.

**SIDE GUARDS**—Available 12 in. to 24 in. high vertical. Flared guards available on 6 in. and 12 in. high only.

