

Magnetic Conveyor Worksheet

Customer _____ Contact _____
 _____ Phone # _____
 _____ Date ____ / ____ / ____ P.O. # _____
 Quote # _____ Job # _____
 Delivery _____ Salesperson _____

Style:

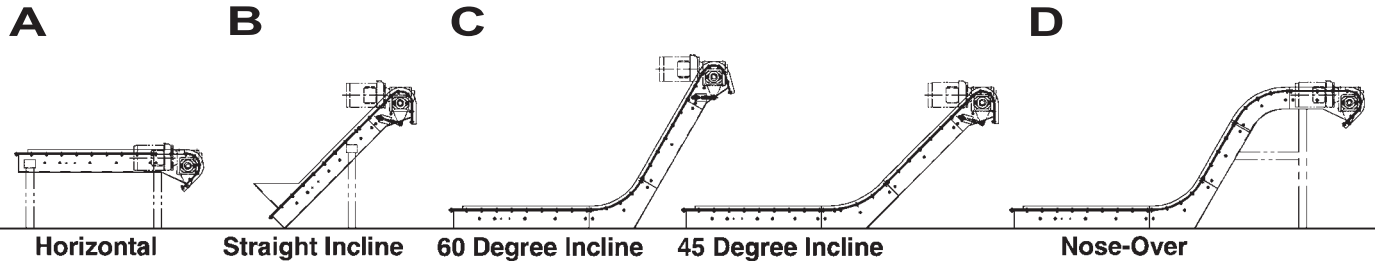

OVERALL DIMENSIONS

Infeed Height: _____
 Discharge Height: _____
 Lower Horizontal Length: _____
 Inclined Angle: _____
 Incline Length: _____
 Upper Horizontal Length: _____

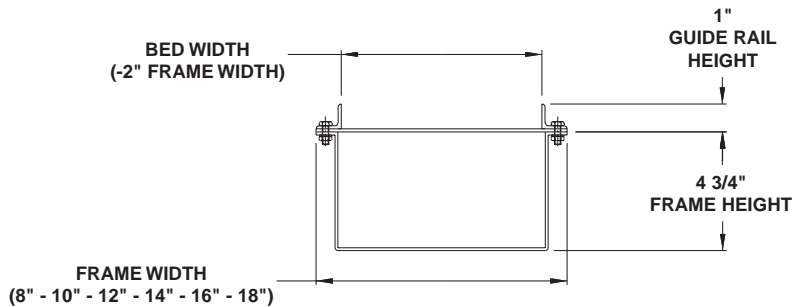

VITAL DATA:

- Production Rate: _____ lb./hr.
- Product to be Conveyed: _____
- Shape and Size of Material:
 _____ x _____ x _____ (L x W x Thk.) - MAX.
 _____ x _____ x _____ (L x W x Thk.) - MIN.
- Dampness of Material: WET or DRY
- Temperature of Material: _____ Degrees Max.
- How Will Product Be Fed to Conveyor: _____
- Motor Voltage: _____ Hp _____ Volts - 3 Ph. - 1 Ph.
- Does Frame Need to be Liquid-Tight: YES or NO
- Will Conveyor Be Submerged (How Deep): _____
- Will Conveyor Require a Receiving Hopper: YES or NO
- Will Material Need Demagnetizing: YES or NO
- Drive Location
 (Looking from tail-end) RIGHT HAND or LEFT HAND
- Coolant Present: YES or NO
- Drainage System Required: YES or NO
- Pit Dimensions (L x W x H): _____ x _____ x _____
- Product Free Fall: _____ Ft. _____ Inches
- Will Product Impact Conveyor Bed: YES or NO
- FPM _____

ADDITIONAL OPTIONS:

- | | | | |
|---|---|--|--|
| <input type="checkbox"/> Supports | <input type="checkbox"/> Lifting Lugs | <input type="checkbox"/> Heavy-Duty Rare-Earth Magnets | Electrical Controls Required: |
| <input type="checkbox"/> Special Paint | <input type="checkbox"/> Hopper | <input type="checkbox"/> Single Phase Motor | <input type="checkbox"/> Start/Stop |
| <input type="checkbox"/> Casters | <input type="checkbox"/> Demagnetizer | <input type="checkbox"/> Rigidized Bed | <input type="checkbox"/> AC Controller |
| <input type="checkbox"/> Torque Limiter | <input type="checkbox"/> High Temp. Chain Guides
(Includes Oil-filled Frame) | | <input type="checkbox"/> E-Stop |
| | | | <input type="checkbox"/> DC Controller |
| | | | <input type="checkbox"/> None |

