

4.0 in. Pitch Hinged Steel Belting

4.0 IN. PITCH HINGED STEEL BELTING

Pans: Plain
Pimpled
Pimpled/Perforated

Side Wings: MIG Welded to Apron Pans

Belt Widths: Available from 6 in. to 48 in. wide in 6 in. increments

Construction: Pin and Cotter

Options: 2-1/2 in. high cleats on centers divisible by 4 in.
Impact Pads
Heat Bars
Special Cleats
Welded Loops

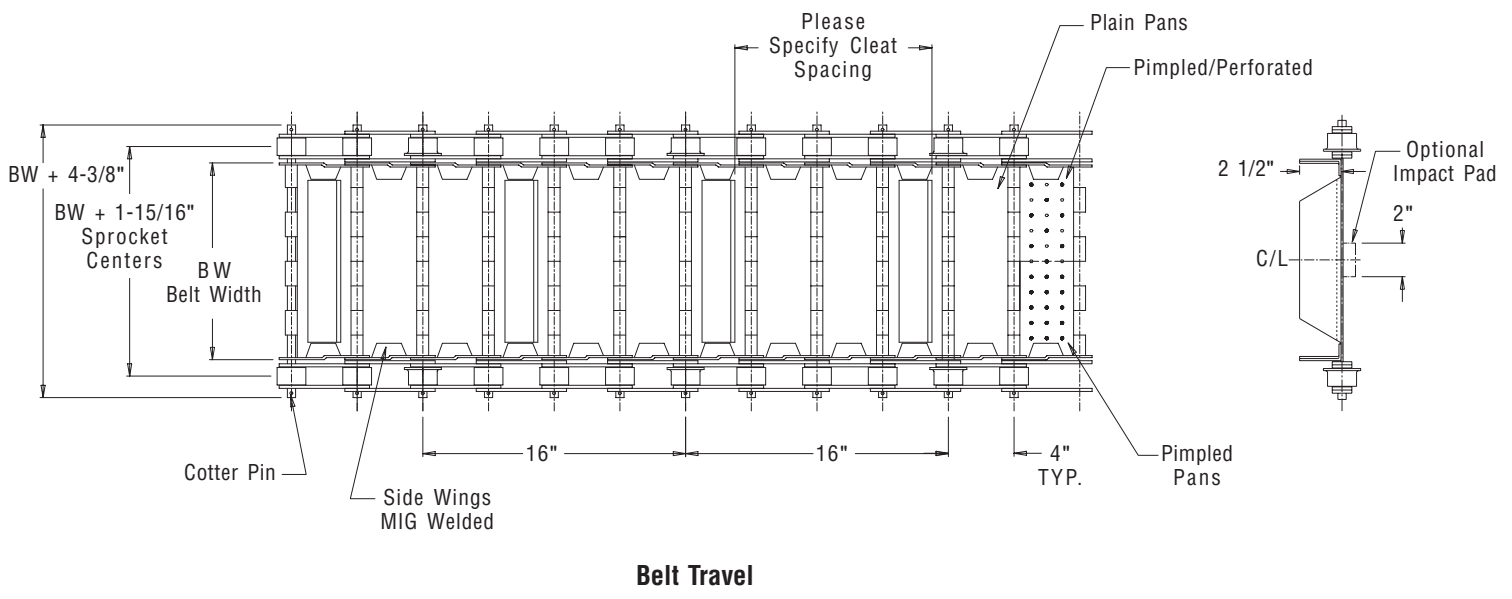
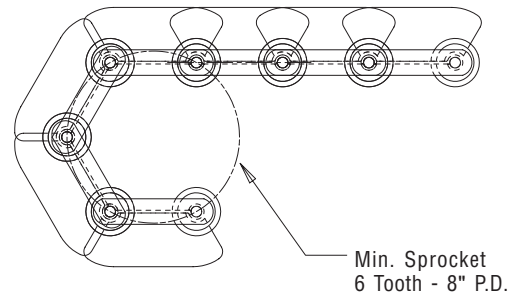

OTHER PRODUCTS AVAILABLE:

- ◆ Chip Conveyors
- ◆ 4", 6", 9" Pitch Hinged Belt Conveyors
- ◆ Slider Bed Conveyors
- ◆ Boxwall Conveyors
- ◆ Parts Conveyors
- ◆ Container Dumpers
- ◆ 2-1/2" Pitch Steel Belting

To Order:

Model Number - 4P - 12 - A
 4" Pitch Belt
 Belt Width
 Pan Type
 "A" = Plain
 "B" = Pimpled
 "C" = Pimpled/Perforated

**Call a Sales Representative
for more information!**

Why Use Endura-Veyor Belting?

ADVANTAGES IN DESIGN

Axles:

Manufactured from high quality stress proof cold rolled steel. Ends milled with flats to interlock in outside side bars.

Rollers:

Made from medium carbon steel and heat-treated for greater wear resistance. Flange rollers every other roller block to guide belt on track.

Roller Bushings:

Roller bushings are made from tubing, not rolled. By using tubing, the bushing maintains more roundness, which creates a more even wear surface. Bushings are heat treated for increased wear resistance. (Some belt manufacturers do not even use bushings.)

Welded Side Wings:

Welding the side wings to the pans keeps material from dropping through gaps between the wings and the pans. This feature reduces the amount of material allowed to migrate to the chain and tracks, which causes increased wear.

Side Bars:

Constructing the chain with inside and outside side bars results in the load being carried by the chain as opposed to applying pressure to the thru axles and pan loops, which occurs when side bars are eliminated. Greater belt pull capacity is achieved with the use of side bars. "D" style outside bars keep the milled end axles from wear caused by the "scrubbing" action that occurs when the chain goes through curves and around sprockets. This feature eliminates that area as a wear point.

DO ALL THESE THINGS MATTER?

Approximately 1/3 to 1/2 of the cost of a hinged steel belt conveyor is the cost of the belt. By using higher quality belting, you can expect increased belt life. Increased belt life saves you money and down time. Consider these things when buying your next belt:

- How often do I want to replace this belt?
- What is my actual cost when I compare cost to belt life?
- What is the cost of labor to replace the belt?
- What is the cost in lost production from down time?

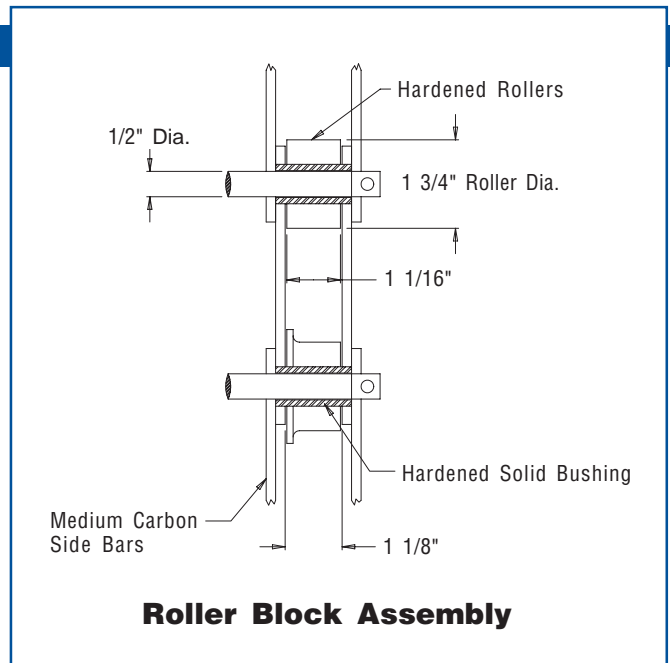

Ordering Information

4P - 24 - D - 36

4 Pitch Belt | 24" Belt Width | D | 36 Cleat Spacing | Pimpled/Perforated Pans



P.O. Box 205 • Alpena, MI 49707 • fax (989) 358-7065 • voice (800) 356-1593

Visit us on the world wide web: www.endura-veyor.com