



Saf-T-Stor® Gas Cylinder Storage Cabinet
Saf-T-10
Assembly Instructions

Providing Reliable Engineered Solutions

TABLE OF CONTENTS:

- PAGE 1 | COVER, TOOLS REQ'D
- PAGE 2 | HARDWARE PROVIDED & PARTS LIST
- PAGE 3 | ASSEMBLY INSTRUCTIONS
- PAGE 4 | ASSEMBLY INSTRUCTIONS (CONTINUED)

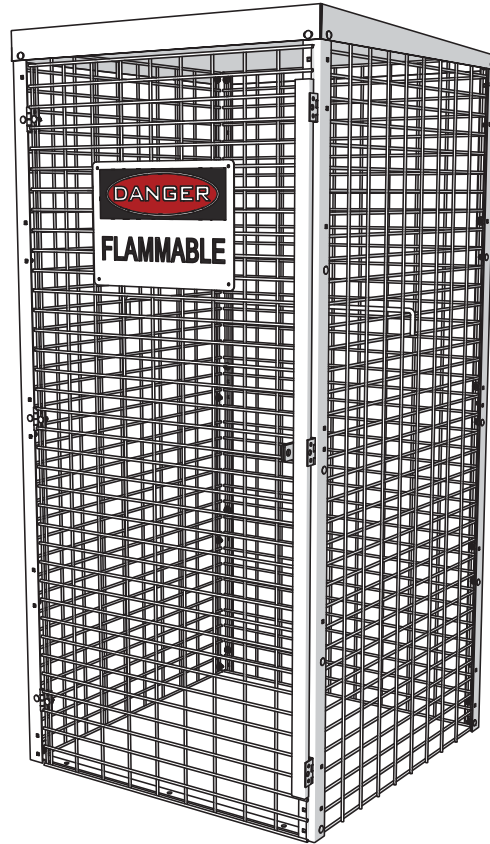

TOOLS REQUIRED:

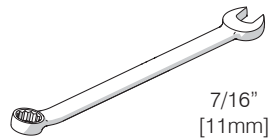
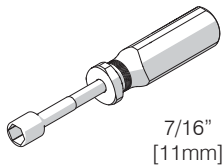

OPEN END WRENCH

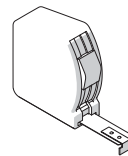

MEASURING TAPE

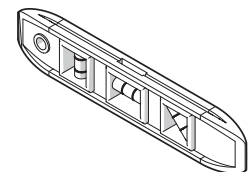

LEVEL

HARDWARE PROVIDED:

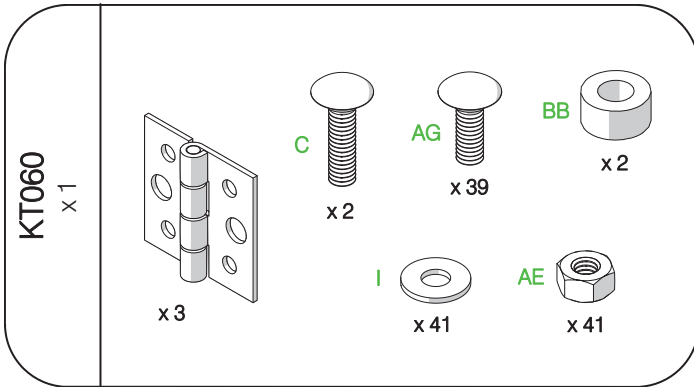

HARDWARE LIST:

- (C) 1/4"-20 x 1" SQUARE NECK CARRIAGE BOLT
- (I) 1/4" FLAT WASHER
- (AE) 1/4"-20 HEX NUT
- (AG) 1/4"-20 x 3/4" SQUARE NECK CARRIAGE BOLT
- (BB) 1/4" LENGTH PLASTIC SPACER

PARTS LIST:

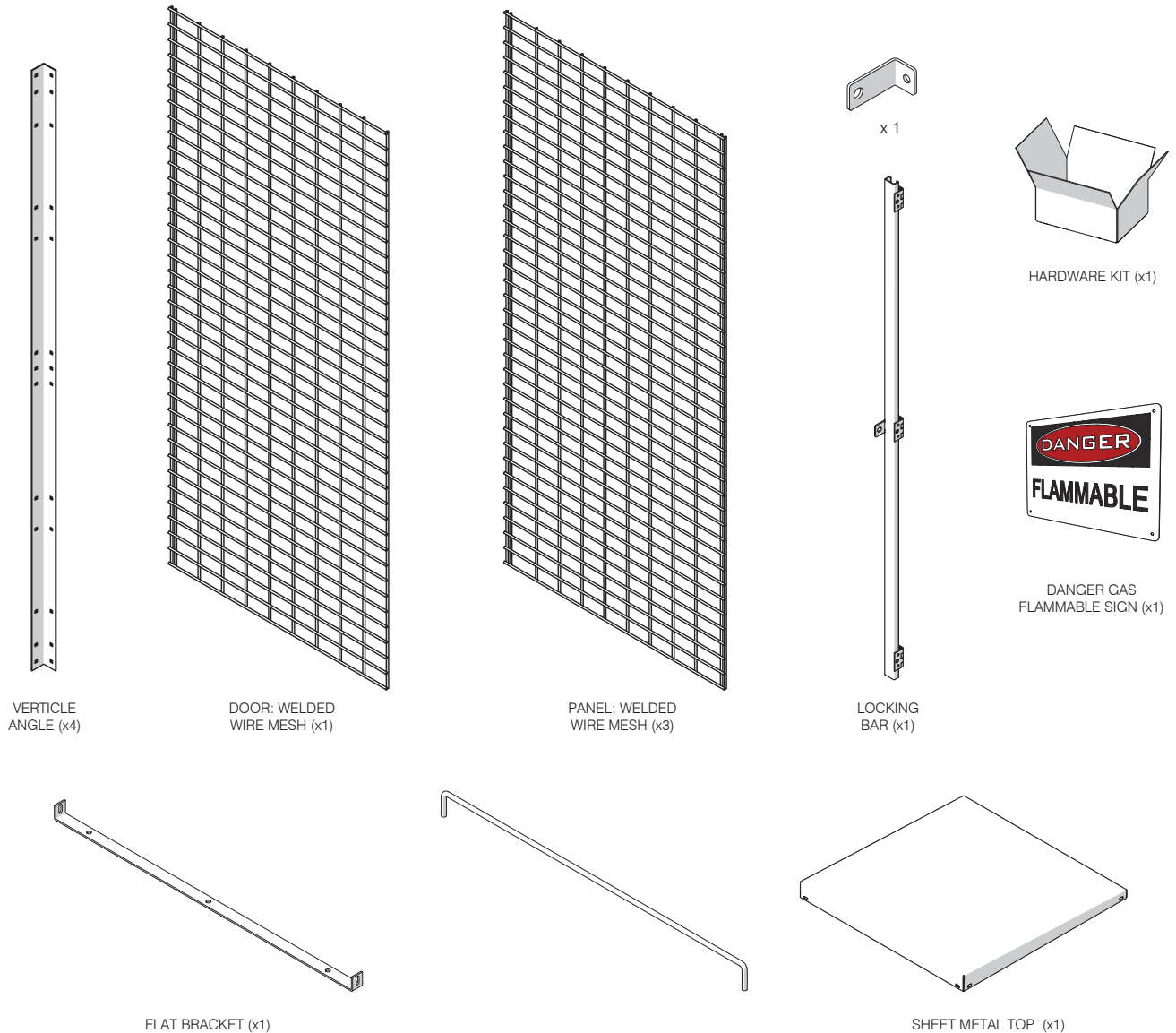

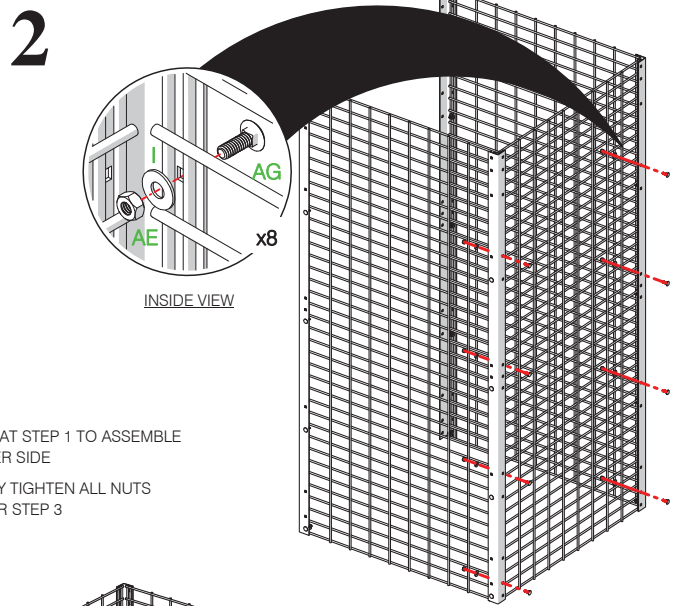
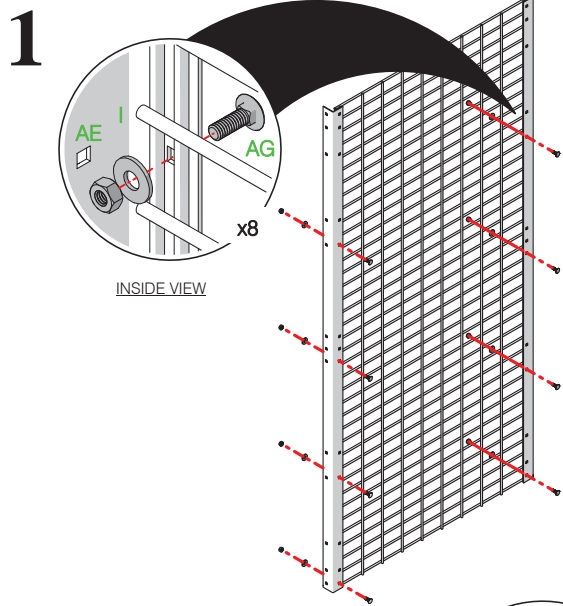

- NOTE:**
- REPEAT STEP 1 TO ASSEMBLE OTHER SIDE
 - FULLY TIGHTEN ALL NUTS AFTER STEP 3

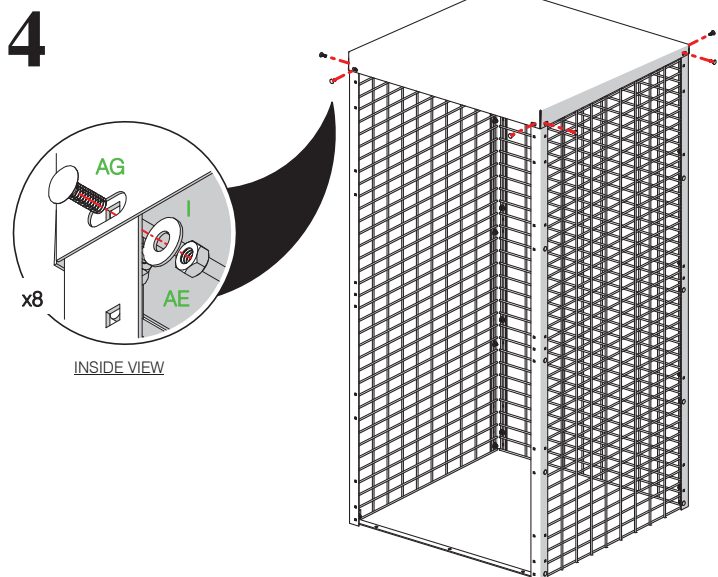
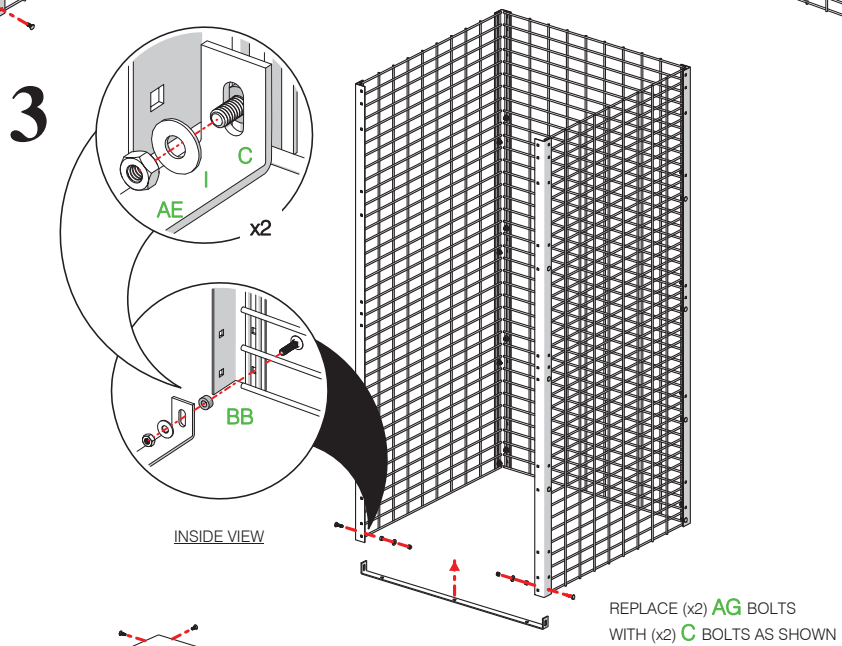

5

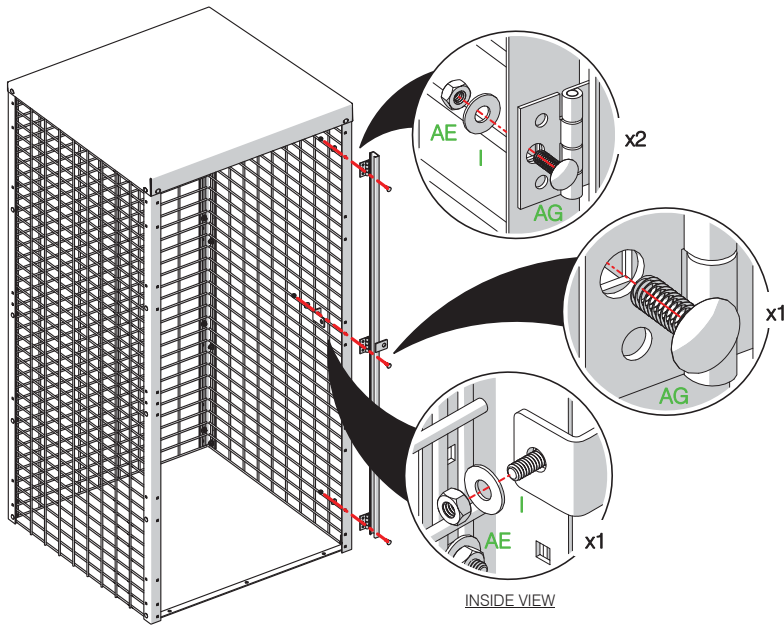

6

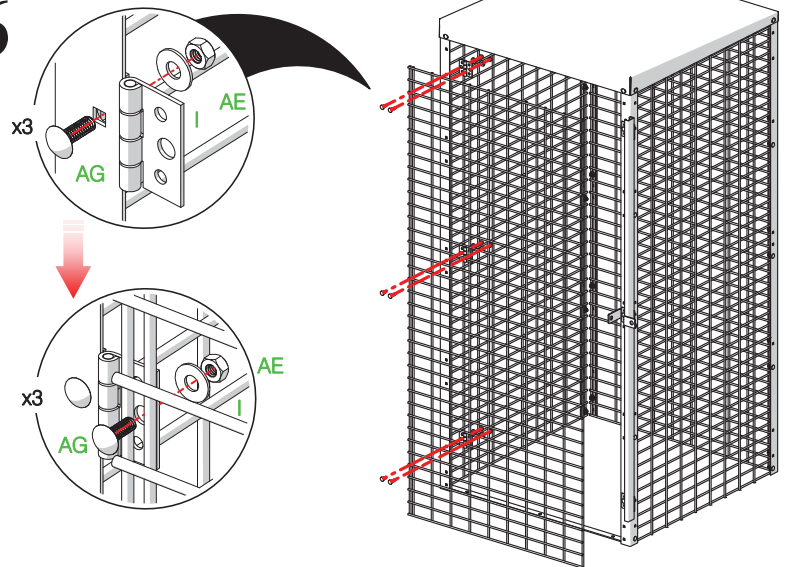

7

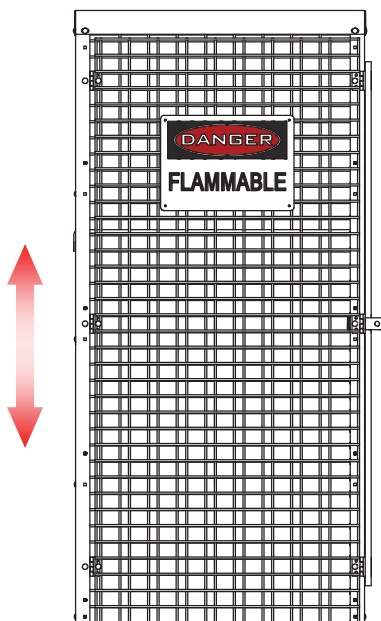

NOTE:

- CHECK DOOR ALIGNMENT, ADJUST DOOR HEIGHT ACCORDINGLY.
- ZIP TIE DANGER SIGN TO LOCKER DOOR