



**TOLL FREE: (800) 622-2214**  
**PHONE (312) 829-3500**  
**FAX: (312) 829-3278**

**2101 S. CARPENTER**  
**CHICAGO, IL. 60606**

# ***LPR SYSTEM<sup>®</sup>***

## ***INSTALLATION***

### ***INSTRUCTIONS***

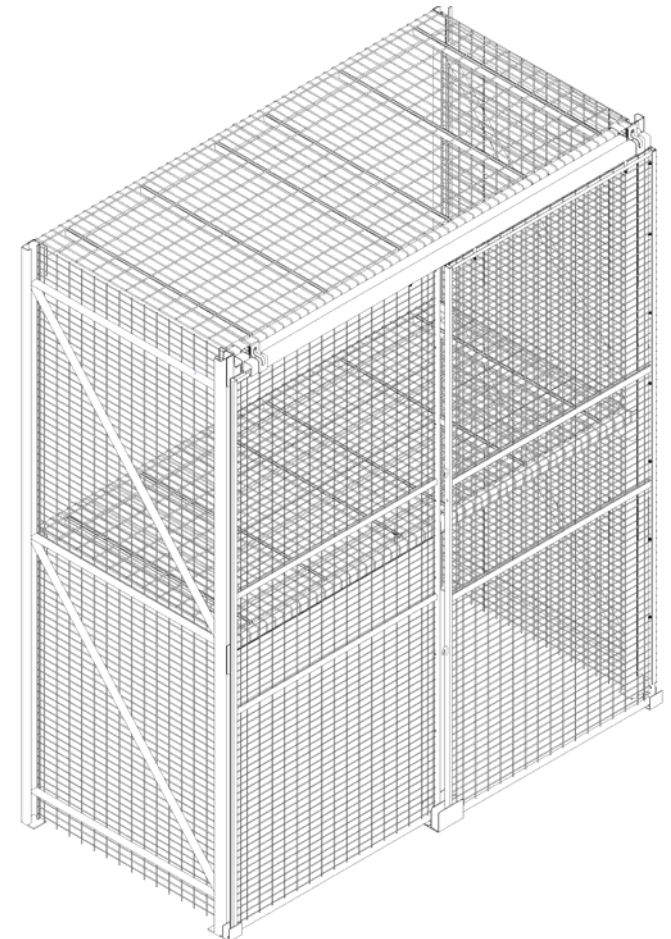

## ***GENERAL INFORMATION***

2101 S. Carpenter      Free: (800) 622-2214  
Chicago, IL. 60606      Phone(312) 829-3500  
Fax: (312) 829-3278

The following installation instructions should be used as a guide for installing Folding Guard LPR System. Good common sense and appropriate safety precautions must be used during installations. The product may be unstable during installation; accordingly - temporary bracing should be implemented until all hardware is tightened and the product is properly anchored to the floor. Permanent field bracing may be installed at installer's/owner's discretion. Install problems arising from job site conditions should be referred to a professional installer. Refer product assembly questions to Folding Guard.

### ***Self-Drilling Screw Installation Recommendations:***

When installing self-drilling screws use a standard variable speed screw gun equipped with an adjustable clutch or depth locating nose piece. Take care not to over tighten or strip, set the drill accordingly. **DO NOT USE IMPACT TYPE GUN WHEN INSTALLING SELF-DRILLING SCREWS.** Securely clamp component parts in place before attaching with self-drilling screws.

#### ***Tools Required:***

- 5/16 Socket Drill Bit Attachment
- 1/2 Masonry Bit
- 3/8 Masonry Bit
- 5/16 Wrench
- Hammer
- Electric Drill (Var. Speed)

#### ***Tools Recommended:***

- Ladder
- Carpenters Level
- Chalk Line
- Heavy Duty Wire cutters
- Floor Anchors (NOT SUPPLIED).  
Recommended 1/2"-20 X  
3 3/4" Anchor.

#### ***Tools Recommended:***

- Tape Measure
- Level
- A Helper

#### ***Prior to Installation:***

- Prior to beginning installation please make sure that you have all the parts required for the assembly
- Make sure that the installation area is clean of all obstructions.
- Read through all the instructions pertinent to your installation.

### ***Installer Tips:***

- Installation is best completed with the help of one to two people.
- Prior to beginning, please read through all instructions pertinent to your installation.
- Panels are to be installed horizontally between posts, parallel with the ground.
- Prior to beginning, if at all possible please lay out the parts where they are to be installed.
- Assembly hardware will be on the inside of most layouts
- Installer should cut off any bolts or hardware protruding into aisle ways or around door openings.

***GENERAL INFORMATION***

2101 S. Carpenter      Free: (800) 622-2214  
Chicago, IL. 60606      Phone(312) 829-3500  
Fax: (312) 829-3278

**Hardware:**

1/4"-20 X 1"  
Carriage Bolt (F1)

8X



1/4"-14 X 1" TEK Self  
Drilling Screw (F4)

30X



1/2"-13 X 3.75 Concrete  
Anchor (F7)

4X



1/4"-20 Hex Nut (F2)

2X

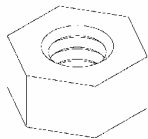

1/4"-20 X 1 3/4" Stop Bolt (F5)

2X



3/8"-16 X 3.75 Concrete  
Anchor (F8) (NOT  
SUPPLIED)

4X



1/4"-20 Hex W/  
Serrated Edge (F4)

8X



7/16"-14 X 3 3/4" Hex  
Head Bolt (F6)

2X

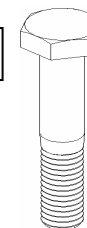

**GENERAL INFORMATION**

2101 S. Carpenter Chicago, IL. 60606  
 Free: (800) 622-2214  
 Phone: (312) 829-3500  
 Fax: (312) 829-3278

**Other Items included:**

Panel Clip (P1)

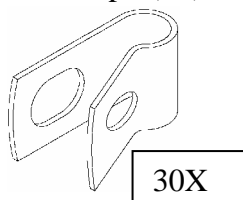

Wire Mesh Shelving (R1)

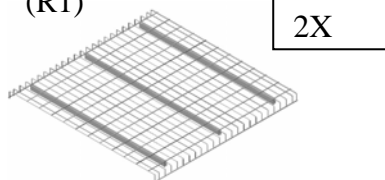

Trolley Assembly (T1)

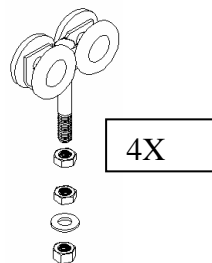

Side Guard (R2)

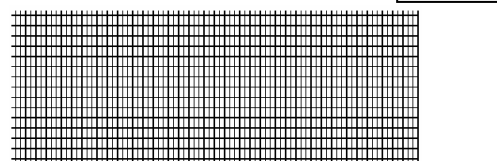

Security Strip (R3)

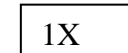

Slide Door Track (S1)

Door #1 (D1)

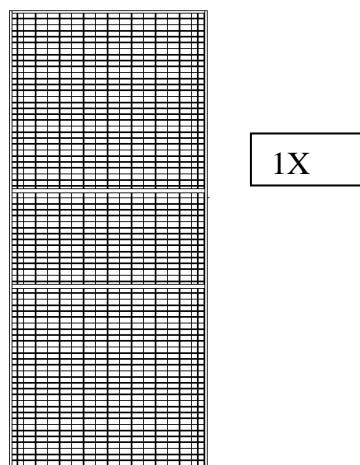

Door #2 (D2)

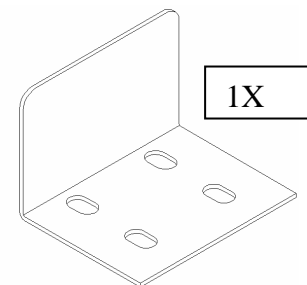
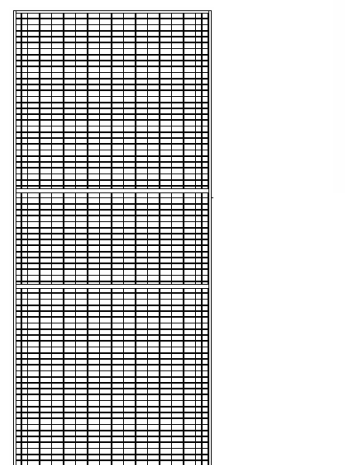

Middle Guide Bracket "A" (G2)

Slide Track Bracket (B1)

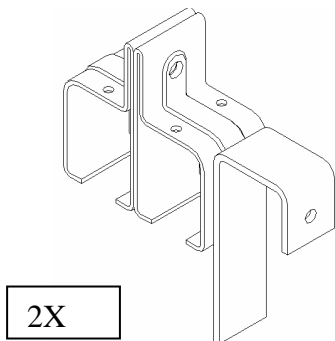

Side Bracket (G1)

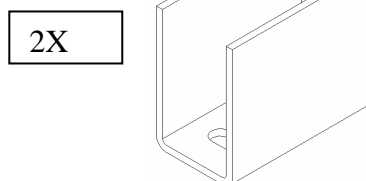

Middle Guide Bracket "B" (G3)

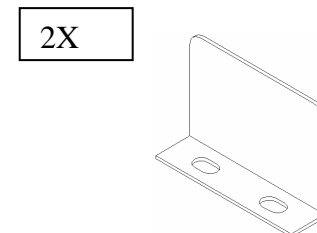

2101 S. Carpenter  
Chicago, IL. 60606

Free: (800) 622-2214  
Phone (312) 829-3500  
Fax: (312) 829-3278

## Step 1: Door Pre-Assembly

- Assemble Door #1 and Trolley Assembly. See Figure 1-1 for reference.
- Assemble Door #2 and Trolley Assembly. See Figure 1-1 for reference.
- Assemble Door #2 and End Capping Channel with the Wide end of the End Capping Channel facing towards the Pallet rack when door is going to be assembled. Secure with the Carriage bolts (F1), Nuts (F4) provided. See Figure 1-2 Provided.

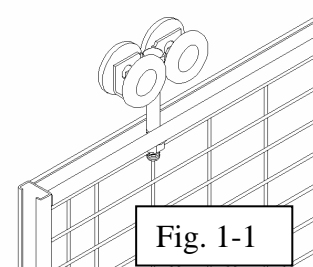

Fig. 1-1

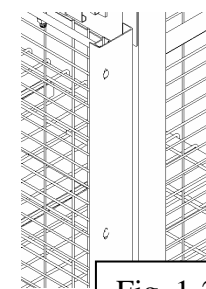

Fig. 1-2

## Step 2: Sliding Track Assembly

- Slide the Slide Track inside one of the openings in the Slide Bracket. See Figure 2-1 for reference.
  - DO NOT Tighten the Bolts in the Slide brackets at this moment.
- Insert the other Slide Track inside the other opening in the Slide Bracket. See Figure 2-1 for reference.
  - DO NOT Tighten the Bolts in the Slide brackets at this moment.
- Insert the second Slide Bracket over the already assembled Slide Track. See Figure 2-2 for reference.
  - DO NOT Tighten the Bolts in the Slide brackets at this moment.

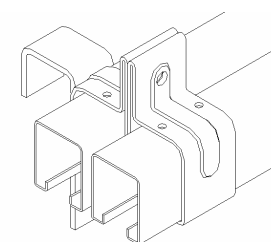

Fig. 2-1

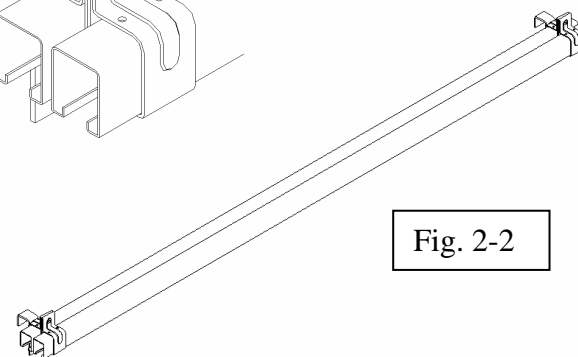

Fig. 2-2

## Step 3: Shelves Assembly.

- Place the Wire Mesh Shelving on top of the Horizontal existing brackets.

## Step 4: Slide Channel Installation.

- Prior to installation
- Install the Slide Track by “hooking” Slide Bracket “hook” over the existing top horizontal support.
  - To do this you will have to CUT OUT a section of wire that is located about 4-5 inches from the edge of the Wire Mesh Shelving.
  - Using the provided HEX HEAD BOLT (F6) tighten the clip to the existing beam.

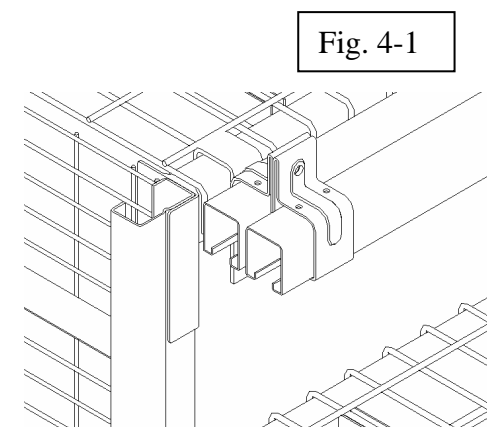

Fig. 4-1

2101 S. Carpenter  
Chicago, IL. 60606

Free: (800) 622-2214  
Phone (312) 829-3500  
Fax: (312) 829-3278

### Step 5 Installing Side Guards.

- Place the Side Guard on the inside of the Existing Pallet Rack.
- Insert a Panel Clip bracket (P1) around the wire and attach to the existing side cross bars. Refer to Figure (5-1) for reference. Repeat all the way down.

### Step 6: Installing Doors.

- Slide the Door #2 Trolleys in first and into the FRONT Slide Track (FRONT of the Track that is farthest away from the Existing Pallet Rack).
- Slide the Door #1 Trolleys in secondly and In the REAR Slide Track.
- Insert the provided Stop Bolt (F12) in the FRONT Slide Track on the Right Side of the Slide Track (Right is side to your Right if you are facing the Pallet Rack and secure with the provided Nut (F2).
- Insert the provided Stop Bolt (F5) in the REAR Slide Track on the Left Side of the Slide Track and secure with the provided Nut (F2).

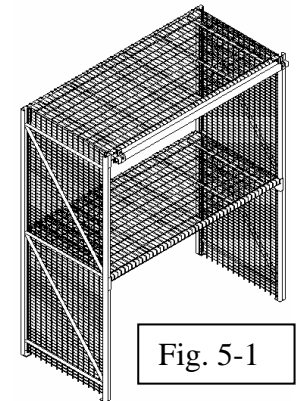

Fig. 5-1

### Step 7: Installing Middle Brackets.

- Locate the Center of the Pallet Rack Opening on the ground and Mark that Location.
- Using a level make the sure the FRONT door is perpendicular to the ground and draw a line along that point perpendicular to the previously drawn centerline of the opening. Place the “A” Middle Guide Bracket on in that location and center the front two holes centerline of the opening (FRONT of the “A” Middle Guide Bracket is flat front facing away from the Pallet Rack).
  - Drill Holes in the ground for the provided ½” Anchors.
    - You may use the Holes on the Middle Bracket As a Guide
    - Make sure to drill for all 4 (four) anchor locations.
- Install the Provided ½”X3¾” – 13” Anchors
- Place the two “B” Middle Guide Brackets on top of the “A” Middle Guide Bracket and the installed ½”X3¾” – 13” Anchors (F7) and secure them together to the floor.

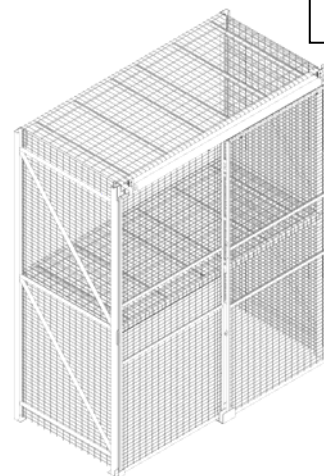

Fig. 7-1

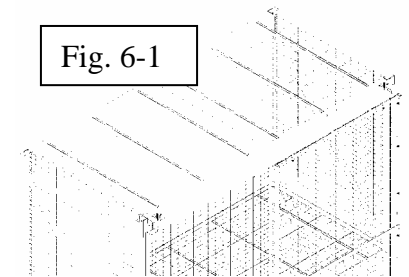

Fig. 6-1

Fig. 7-4

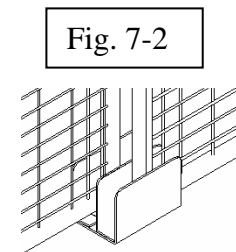

Fig. 7-2

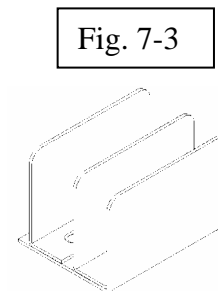

Fig. 7-3

2101 S. Carpenter      Free: (800) 622-2214  
Chicago, IL. 60606      Phone (312) 829-3500  
Fax: (312) 829-3278

**Step 8: Installing Side Brackets.**

- Place the Bracket (G1) for the BACK door approximately 1” from the base of the vertical post to the back end of the Side Bracket (G1).
- Line up the sides of the Side Bracket (G1) with the sides of the posts. Refer to Figure 8-1 for visual instructions
- Place the Bracket (G1) for the FRONT door approximately 2½” from the vertical post to the back one of the Side bracket (G1) (Please make sure it is set on the opposite side of the BACK door Side Bracket)
- Line up the sides of the Side Bracket with the sides of the post.
- Using the holes in the brackets (G1) as a guide drill an appropriate hole for a 3/8”X3¼” Anchor (F8).
- Install the Anchor (F8) and set the Side Bracket (G1) on top of it and secure it.

**Step 9: Securing the Assembly.**

- Adjust the End Capping Channel (R3) so that the gap between the Door and the Pallet Rack is minimal.
- Tighten the assembly.
- Make sure the doors slide freely in either direction and tighten the bolts in the Slide Track Bracket.

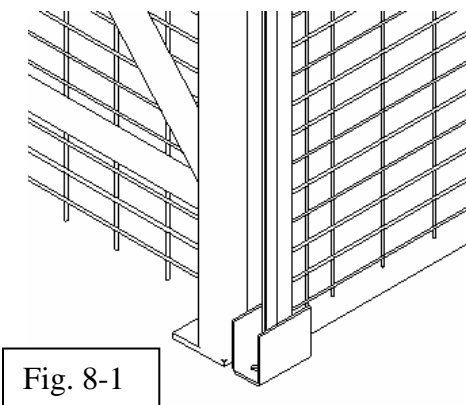

***THANK YOU FOR USING***



***LOSS PREVENTION<sup>®</sup> PRODUCTS***





**GENERAL INFORMATION**

2101 S. Carpenter Chicago, IL. 60606 Free: (800) 622-2214 Phone(312) 829-3500 Fax: (312) 829-3278

In our effort to provide you with a more comprehensive experience with Folding Guard© current and future products we like would like to hear from you. Please answer the following questions. Fax it to our Main Office at: (312) 829-3278, or fold along the dotted lines, tape shut and mail it to us. We look forward to hearing from you and will address your comments and suggestions in a timely manner.

Quote Number:

Installation Date:  /  /

How would you rate the quality of these instructions, please check all that apply:
 Confusing  Too much information  Not enough information
 Other: \_\_\_\_\_  Easy to Understand  More Visual Material  More Text Material

Were the instructions clear and concise, if no please write down what wasn't: \_\_\_\_\_

Did you run into any problems during the installation of the product, if yes please describe them: \_\_\_\_\_

Are you satisfied with our product? If not please let us know how we can improve it: \_\_\_\_\_

Comments: \_\_\_\_\_