

Assembly/Operating Instructions with Parts List



Bulletin No. 592
**MODEL
BL**
July 2007
(Supersedes June 1999)

RECOMMENDED SPARE PARTS LIST HIGHLIGHTED IN GRAY

En Español Pag. 4

MODEL "BL" — PORTABLE FOLDING "CLEATED" CONVEYOR

UNCRATING—Remove all crating and strapping. Some optional equipment such as floor locks and remote control parts may be fastened to inside of conveyor bed or frame. Check to see whether these parts or any loose, foreign pieces, which could have dropped into conveyor during shipment, are removed.

TO OPERATE—Unfold—place hinge levers horizontal and unfold conveyor bed to its full length. Check to see that joint at hinge is flush and even. Plug into electrical outlet making sure correct voltage and power is available.

MOTOR—The standard motor is 115/230 Volts—Single Phase. It will be wired for 115 volts unless otherwise specified. Avoid weak lighting circuits and long extension cords. Heavy power wiring will insure better motor performance and enable conveyor to carry the rated loads.

TO ELEVATE—To elevate conveyor bed to its desired height or incline, run motor so belt travels away from drive pulley and move lever on right side back. To lower, reverse belt travel and move same lever. **Caution:** *Do not raise or lower with load on conveyor belt.*

TO FOLD—Push hinge levers vertically. Lift top end of conveyor bed slightly when moving these offset levers. Fold top section back while holding belt to conveyor bed. This will keep belt from dragging on the floor when rolling folded conveyor for storage.

TO LUBRICATE—Grease fittings in drive pulley bearings at lower pivot on each side of drive pulley should be filled periodically depending on use. Tail pulley at top end has cast-iron non lube bearings. Oil the roller chain and return idlers periodically. Speed reducer is filled with SAE 90 (use lighter in freezing temperature) gear lubricant and sealed at the factory. If reducer runs too hot, check oil level. Reducer must be removed for refilling. Keep raising screw greased with SAE 90 gear lubricant.

DRIVE ROLLER CHAIN—Can be adjusted by loosening speed reducer bolts and moving reducer back with 3/8" take-up screw on base plate. Tighten speed reducer bolts before running. Remove a link out of chain if limit of adjustment is reached.

BELT TENSION—To insure maximum rated load capacity on conveyor belt, maintain enough tension so that drive pulley will not slip under belt when carrying full load. Screw take-ups on tail pulley will tighten belt. Because of climatic conditions or after lengthy service, it may be necessary to shorten belt. A short additional piece of belt (called a "Dutchman") is inserted and can be removed when the limit of screw take-up is reached. If more take-up is required, cut and reface conveyor belt to maintain proper belt tension.

TRACKING THE BELT—All conveyors are assembled and run at the factory, and the belt is tracked before shipment. In the event the belt does not track, follow these instructions: Be sure tail pulley (top end) is square with conveyor bed. For belt running in the forward (up) direction, if belt runs off the right, move snub idler on right side back (toward lower drive pulley). When belt is running off to the left move at opposite side. For belt running in reverse (down) direction, if belt runs off to the right, move right side of tail pulley (top end) out. When belt is running off to the left, move at opposite side.

Model "BL" Parts Drawing

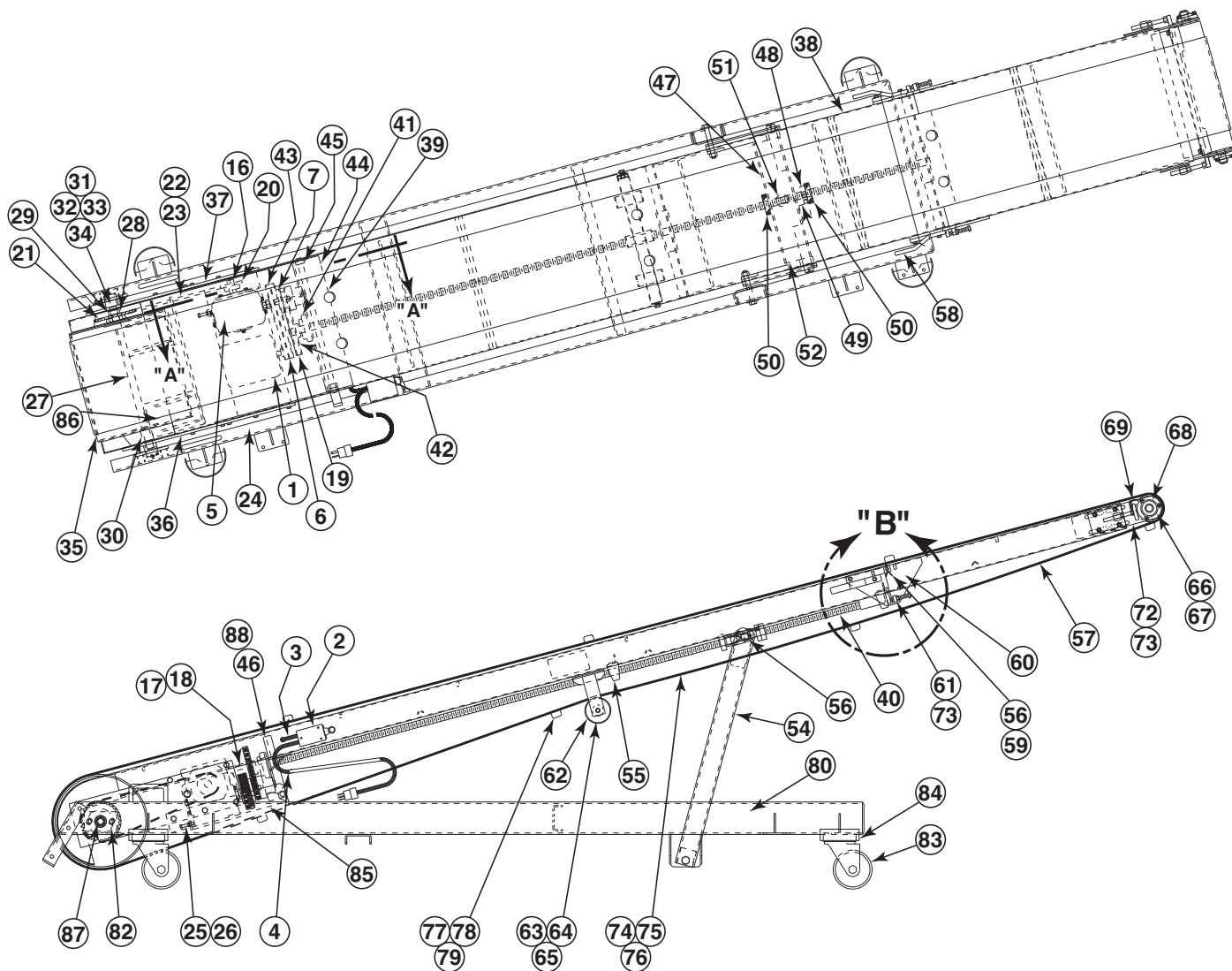
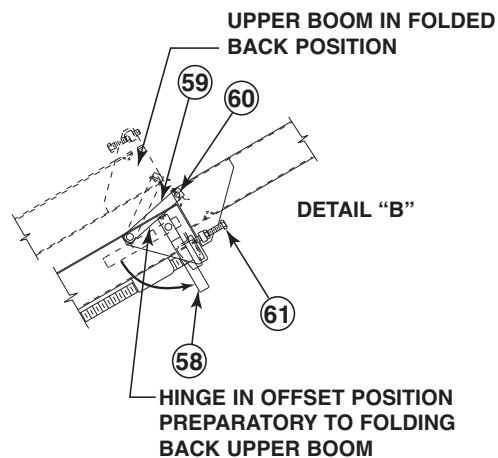
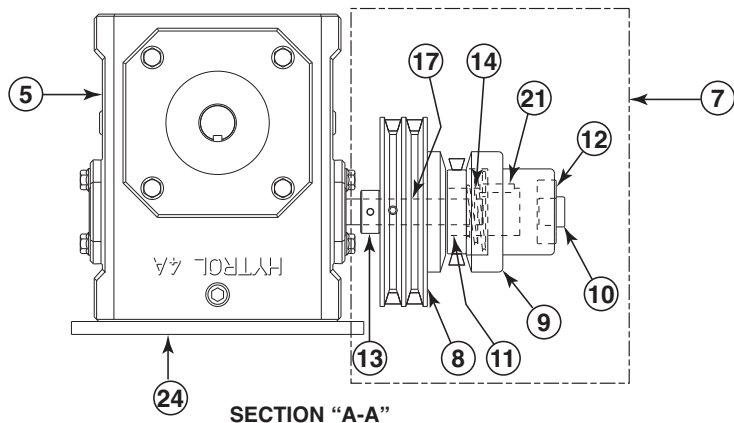

Model "BL" Parts List

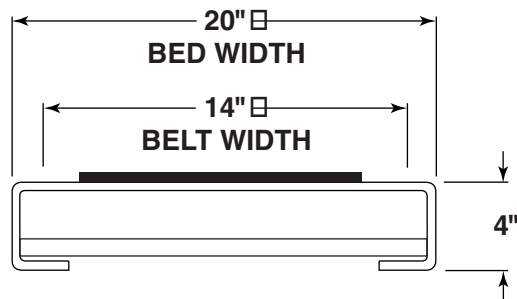

RECOMMENDED SPARE PARTS LIST HIGHLIGHTED IN GRAY

Ref. No.	Part No.	Description
1	—	Motor—Foot Mounted
—	030.4014	1 HP—115/230VAC—3 Ph.—60 Hz.—TEFC
2	032.103	Reversing Drum Switch—1 Ph.—NEMA 1
3	034.107	Power Cord—Motor to Switch (36 in. Long)
4	034.105	Power Cord with Wall Plug #034.201 (20 ft. Long)
5	R-00152-20R	4A Speed Reducer—RH—20:1 Ratio
6	021.101	Motor Sheave—2.25 in. Dia. x 5/8 in. Bore
7	B-06164	Clutch Complete
8	B-00112	Clutch Pulley—5.5 in. Dia x 3/4 in. Bore
9	B-00113	Sliding Sleeve
10	093.2011	Bearing Plug
11	011.101	Bearing—1 Row Radial, 2.44 in. O.D. x 1.38 in. I.D.
12	011.102	Bearing—1 Row Radial, 1.85 in. O.D. x .78 in. I.D.
13	098.182	Lock Collar—3/4 in. I.D. x 9/16 in. Long
14	093.103	Clutch Spring
15	090.202	Shaft Key—3/16 in. Sq. x 1 in. Long
16	090.203	Shaft Key—1/4 in. Sq. x 1 in. Long
17	B-14414	Clutch Guard Assembly
18	B-12633	Clutch Side Guard
19	066.105	V-Belt (4L270)
20	028.115	Sprocket—Reducer, 50B15 x 1 in. Bore
21	027.100	Sprocket—Drive Pulley, 50A30 x 1 in. Bore
22	029.101	#50 Riveted Roller Chain
23	029.201	Connector Link—#50 Roller Chain
24	B-01323-020	Motor Base Plate
25	040.307	Take-Up Bolt—3/8-16 x 2-1/4 in. Long
26	041.300	Hex Jam Nut—Heavy—3/8-16
27	B-00019	Drive Shaft Assembly
28	098.160	Sprocket Spacer—33/64 in. I.D. x 5/8 in. Long
29	098.155	Drive Shaft Spacer—1 in. I.D. x 11/16 in. Long
30	098.156	Drive Shaft Spacer—1 in. I.D. x 1-15/16 in. Long
31	012.101	Solid Rlr. Bearing w/Split Race—1" I.D. x 1-1/2" Lg.
32	B-00015	Bearing Retainer
33	093.107	Spring Cup—1-5/8 in. Dia.
34	092.103	Grease Fitting—1/8 in. PFT Straight Sp. Ext.
35	B-00415-020	14 in. Dia. Drive Pulley Assembly
36	B-00133	Drive Mount Plate—RH
37	B-00134	Drive Mount Plate—LH
38	B-01941-002	Lower Boom Assembly
39	B-00143	Stop Angle Assembly
40	B-00125	Power Lift Screw
41	010.2005	4-Bolt Flange Bearing—7/8 in. Bore
42	020.124	Sheave—7 in. O.D. x 3/4 in. Bore
43	066.109	V-Belt (4L310)
44	B-01014-020	Clutch Lever Rod

Ref. No.	Part No.	Description
45	098.182	Lock Collar—3/4 in. I.D. x 9/16 in. Long
46	B-00120	Short Clutch Handle Assembly
47	B-23646	Elevating Bar Beam Assembly
48	B-00645	Angle—Elevating Bar Beam
49	B-00282	Safety Stop
50	099.525	Safety Stop Felt
51	B-25024	Acme Nut—1 in.-1/8
52	B-00117	Cross Beam Roller
53	010.300	Pillow Block Bearing—3/4 in. Bore
54	B-00118	Elevating Bar Assembly
55	010.3011	Pillow Block Brg.—1" Bore
56	090.102	Cotter Pin—3/16 in. Dia. x 1-1/2 in. Long
57	—	Upper Boom Assembly
—	B-00090-068	68 in. Long (20 ft. Long Model)
—	B-00090-092	92 in. Long (22 ft. Long Model)
58	B-00270	Hinge Lever
59	B-00267	Hinge Rod
60	B-00078	Hinge Link
61	040.4061	Hex Head Bolt—1/2-13 x 3 in. Long
62	B-00631	Return Idler Bracket Assembly
63	B-00292	Spooled Idler Tube Assembly
64	B-01524	7/16 in. Hex Shaft
65	041.502	Hex Locknut—1/2-13
66	010.102	3-Bolt Flange Bearing—1 in. Bore
67	B-07987	Bearing Spacer
68	B-22221-020	4 in. Dia. Tail Pulley Assembly
69	B-09859-020	Nip Point Guard
70	B-19614-R	Take-Up Plate—RH
71	B-19614-L	Take-Up Plate—LH
72	040.407	Take-Up Bolt—1/2-13 x 4 in. Long
73	041.201	Hex Jam Nut—1/2-13
74	065.004	Belt, Black Trackmate 120 RT (14" Wide) (Spec. Lgth)
75	—	U3 Unibar Lacing (Specify Length)
76	—	#13 Lacing Pin (Specify Length)
77	099.105	Cleat—1-1/2 in. Dia. Wooden
78	042.4009	Elevating Bolt—5/16-18 x 1 in. Long
79	041.101	Hex Nut—5/16-18
80	B-00137	Base Assembly
81	B-01670	Support Angle Assembly
82	B-00284	Main Pivot Bracket
83	014.102	Caster, 6 in. Dia. Semi—Steel Swivel
84	B-00519	Corner Guard
85	B-21145	Take-Up Cam
86	B-01286	Nip Point Guard
87	049.3053	External Retaining Ring
88	099.1026	Handle Grip
89	B-19619	Attachment Plate Assembly

Instrucciones de Ensamblaje/Operación y la Lista de Partes

MODELO BL

PARTES DE REPUESTO RECOMENDADAS SE RESALTAN EN GRIS

MODELO “BL” Transportador Plegable con Retenedores

DESEMBALAJE—Remueva todo el empaque y amarres. Algún equipo opcional como seguros de piso o partes de control remoto pueden estar asegurados dentro de la cama del transportador o en sus alrededores. Revise si hay material o piezas ajenas que se hayan caído dentro del transportador durante el envío.

PARA OPERAR—Despliegue - ponga las bisagras a nivel horizontal y desdoble la cama del transportador a su tamaño completo. Revise si el enlace y la bisagra esta parejo y al mismo nivel. Conectelo en el enchufe eléctrico asegurándose de que el correcto voltaje esta disponible.

MOTOR—El motor estándar es 115/230 volts en una fase singular. Será cableado con 115 volts al menos de que se especifique lo contrario. Evite circuitos de alumbrado débil y extensiones largas. Cables de poder pesado asegurarán un mejor funcionamiento del motor y hacen posible que el transportador lleve la carga considerada.

PARA ELEVAR—Para elevar la cama del transportador a su altura deseada o inclinación, ponga el motor en marcha y que la banda viaje aleándose del a banda motriz y mueva la palanca del lado derecho hacia atrás. Para bajar, ponga en reversa la banda y mueva la misma palanca. **Precaución:**
No levante o baje la banda del transportador con carga.

PARA PLEGAR—Empuje verticalmente las palancas de las bisagras. Levante el extremo superior de la cama del transportador levemente cuando desalinee estas palancas. Pliegue la sección de superior hacia atrás mientras detiene la banda a la cama del transportador. Esto evitará que la banda se arrastrarse por el suelo cuando se lleve el transportador doblado a guardarse.

PARA LUBRICARSE—El accesorio de engrasado que se encuentra en el pivote inferior, a cada lado de la polea motriz, debe ser llenado periodicamente dependiendo su uso. La polea de retorno en el extremo superior tiene rodamientos de acero sellados y prelubricados. Aceite periodicamente la cadena de rodillo y los rodillos de retorno. El reductor de velocidad es llenado con lubricante SAE-90 (use uno mas ligero si está en temperaturas congelantes) y sellado en la fabrica. Sí el reductor se calienta demasiado, revise el nivel del aceite. El reductor debe ser removido para ser rellenado. Mantenga engrasado en tornillo alizador con el lubricante SAE-90.

CADENA MOTRIZ—Puede ser ajustada aflojando los tornillos del reductor de velocidad y moviendo el reductor hacia atras con 3/8 pulgadas de los tornillos tensores en la placa base. Apriete los tornillos del reductor antes de poner en marcha. Remueva un pedazo de cadena si el ajuste llega a su límite.

TENSION DE LA BANDA—Para asegurar el máximo de carga considerada en la banda del transportador, mantenga suficiente tensión para que la polea motriz no se resbale bajo la banda cuando se use la carga completa. Los tornillos tensores en la polea de retorno, apretarán la banda. Por condiciones climáticas o despues de un largo servicio, deberá reducirse la banda del transportador. Una pieza pequeña adicional de banda (llamado “Dutchman”) es insertado y puede ser removido cuando el límite de los tornillos tensores es alcanzado. Sí más tensión es necesaria, corte y re-enlace la banda del transportador para obtener la tensión correcta.

ALINEACION DE LA BANDA—Todos los transportadores son ensamblados y probados en la fábrica y la banda está alineada antes del envío. En caso de que la banda no esté alineada, haga lo siguiente: Asegúrese de que la polea de retorno (extremo superior) esta cuadrada con la cama del transportador. Cuando la banda corra en dirección delantera (hacia arriba), y si esta corre hacia la derecha, mueva el lado derecho del rodillo de alineación hacia atras (hacia la polea motriz inferior). Cuando la banda corra hacia la izquierda muévelo del lado opuesto. Cuando la banda se usa en sentido contrario (hacia abajo), y si esta corre hacia la derecha, mueva el lado derecho de la polea de retorno (extremo superior) hacia afuera. Cuando la banda corra hacia la izquierda muévelo del lado opuesto.