

190-E24EZ

24 VDC Live Roller Conveyor (Zero Pressure Accumulating Type)

The model 190-E24EZ Accumulating Conveyor uses a series of 24 VDC motors to drive the tread rollers, eliminating the need for drive belts, chains, or line shafts.

Quiet operation, zero pressure accumulation, and ease of maintenance and installation are just some of the advantages.

- EZLogic® Accumulation System
- All-Electric Operation
- Adjustable MS-Type Floor Supports Available



Conveyor shown with optional floor supports and optional EZLogic® cover.



U.S. Patent Numbers
5,862,907 • 7,243,781 • 7,591,366
Other Patents Pending.

Section Length	Between Rail Width	9"	11"	13"	15"	17"	19"	21"	23"	25"	27"	31"	33"	37"	39"
	Overall Frame Width	12"	14"	16"	18"	20"	22"	24"	26"	28"	30"	34"	36"	40"	42"
10'-0"	Weights (lbs.)	320	335	350	365	375	390	405	415	430	445	470	485	510	525
Per Foot	Weights (lbs.)	20	21	23	24	26	27	28	30	31	32	35	36	39	41

Note: Bed Sections available in the following multiples:
18" Zones-3; 4'-6", 6', 7'-6", 9'
24" Zones-2; 4, 6, 8' & 10'
30" Zones-2 1/2; 5, 7 1/2' & 10'
36" Zones-3; 6, 9'

HOW IT WORKS

The conveyor is divided into accumulation zones. Each zone is powered by a 24VDC Motor. The motor may be turned off to cause product in that zone to stop. Hytrol's EZLogic™ Zone Controllers sense product presence and control the accumulation and release of product from the zones.

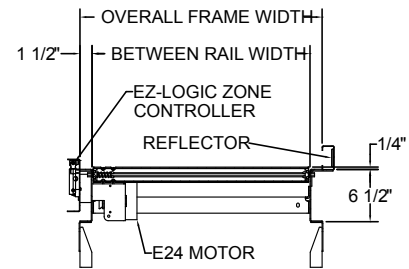
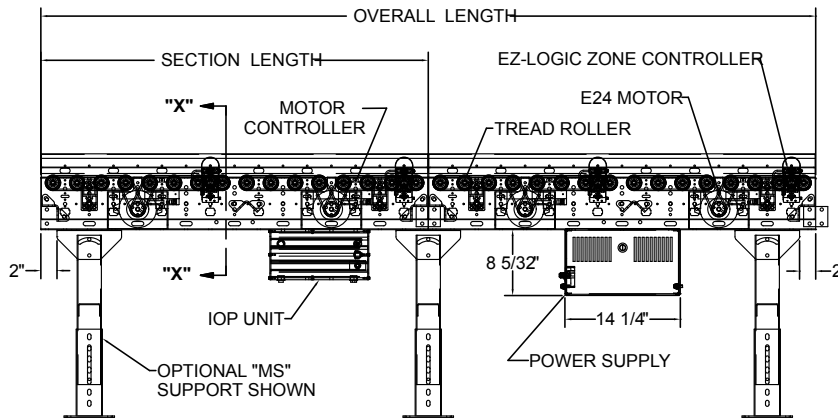

SECTION "X"- "X"

190-E24EZC

Powered Roller Curve Conveyor (Zero Pressure Accumulating Type)

- EZLogic Accumulation System
- All-Electric Operation
- Adjustable MS-Type Floor Supports Available



U.S. Patent Numbers
5,862,907 • 7,243,781 • 7,591,366
Other Patents Pending.

Between Rail Width	Overall Frame Width	"R"	Number of Rollers	90° & 60° WEIGHTS (Lbs.)	45° & 30° WEIGHTS (Lbs.)
15"	18"	32 1/2"	20	220	121
17"	20"			240	132
19"	22"			260	143
21"	24"			280	154
23"	26"			300	165
25"	28"			310	171
27"	30"			325	178
31"	34"	48"	30	495	274
33"	36"			520	286
37"	40"			565	311
39"	42"			590	325

All weights in catalog are conveyor weights only. Accessories, crating, etc., are not included.

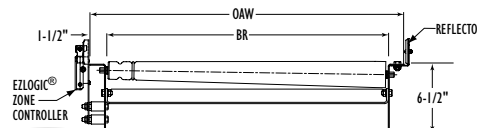
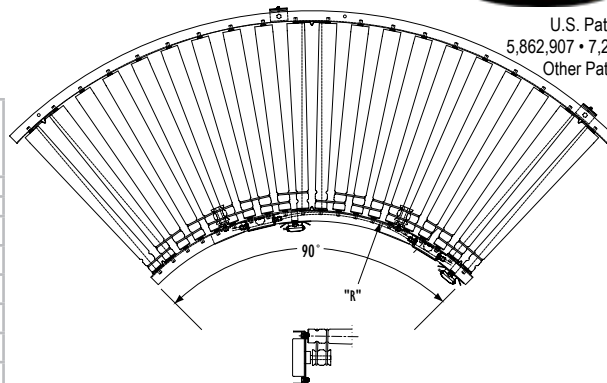

• STANDARD SPECIFICATIONS

BED (E24EZ)—Roller bed with 1.9 in. dia. roller x 16 ga. galvanized tube bearings spaced every 3 in. Mounted in 6 ½ in x 12 ga. powder painted formed steel channel frame bolted together with splice plates.

BED (E24EZC)—Roller bed with 2 ½ in. dia tapered to 1 13/16 in. dia. x 16 ga. galvanized. Mounted in 6 ½ x 12 ga. powder painted formed steel channel frame.

MOTOR—24 VDC motor. One in each zone of conveyor mounted on inside of BR on straight section only

SLAVE O-RINGS—3/8 in. dia. polyurethane o-rings slave-drive zone tread rollers from motor.

ACCUMULATION ZONES—18 in., 24 in., 30 in., and 36 in. zones available.

EZLogic[®] ZONE CONTROLLER—Located in each zone. (Retro-reflective). NEMA 1, 2, IP 62. UL Approved.

MOTOR CONTROLLER—Controls and protects motor. One located in each zone.

POWER SUPPLY (FOR MOTORS)—40 amp DC power supply, 28 volt fixed output. Maximum of 40 zones per power supply. 120 vac, 24 amp input. Mounted near center of conveyor.

IOP—Provides 27VDC, 100 watt power for EZLogic[®] accumulation system - contains slots for 4 input/output boards. Operates up to 50 zones with maximum of 25 on either side of IOP. Requires 120VAC or 230VAC single phase input.

CONVEYING SPEED—35-125 FPM, set on Motor Controller.

CAPACITY—Maximum load 37 lbs. per foot, 75 lbs. per zone.

FLOOR SUPPORTS—Now supplied as optional equipment.

EZLOGIC[®] ACCUMULATION SYSTEM

Hytrol's EZLogic[®], or "Electronic Zero-pressure Logic" Accumulation System, combines the sensing accuracy of photo-electronics with discrete electronic logic control without the use of a PLC or pneumatic logic components. The EZLogic[®] Accumulation System provides many features including:

Zero-Pressure Accumulation of Product

Zone Stop function is built in. Any zone may be transformed into a workstation by connecting a dry contact switching device to the auxiliary port of the EZLogic[®] Zone Controller. This feature is always used at the discharge end of the conveyor line, and may be used at any other location where a zone stop is required.

Selectable Modes of Operation

Singulation Mode – Product separates while traveling down the conveyor and when it is released from the conveyor - creating a zone-length gap between products.

Enhanced Slug Mode w/ Jam Protection – Product does not separate when traveling down the conveyor or when it is released from the conveyor. This allows higher product throughput at any given conveyor speed. Product will not separate on the conveyor even when accumulation has been activated at the discharge end.

Cascaded Slug Release – Rather than releasing all zones simultaneously, this function introduces a momentary delay in the release of each zone, from discharge upstream.

Dynamic Zone Allocation – Automatically adjusts the conveyor's zone length to accommodate the length of the product being conveyed. Improves conveyor efficiency and system flexibility.

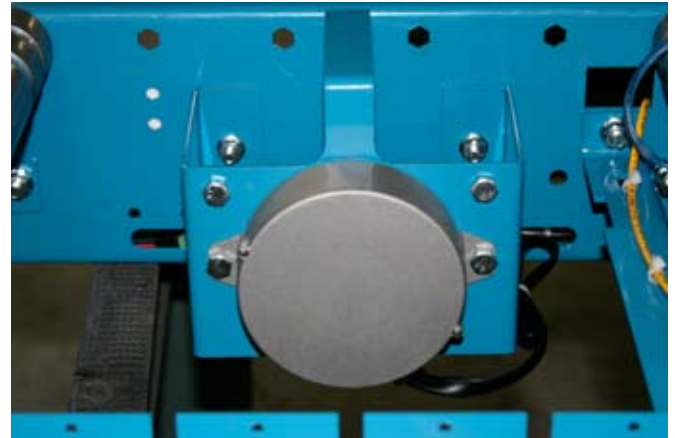

Conveyor shown in standard Hytrol Blue.



• OPTIONAL EQUIPMENT

FLOOR SUPPORTS—MS Type floor supports are available with a wide range of adjustment. Specify top of belt or roller elevation. One support required at every bed joint and ends of conveyor. Holes in feet for lagging to floor. Knee braces recommended above MS-6 support.

POWER SUPPLY (FOR MOTORS)—20 amp power supply available. 20 zones maximum. 120 volt @ 12 amps.

POWER SUPPLY (FOR MOTORS) 460 volt, 3 phase – 20 and 40 amp available.

Motors mounted on outside of channel.

POLY-TIER SUPPORTS—36 in. to 120 in. support heights in 6 in. increments. Knee braces required.

CEILING HANGERS—½ in. dia. x 8 ft. long unplated steel rods fully threaded. Other lengths and galvanized rods available.

HIGH-SPEED DRIVE SPOOL—Provides a speed range of 50-200 FPM.

EZLogic[®] – See EZLogic[®] Components Page.