

Chapter 3 Assembling the Storage Ladder

This chapter provides step-by-step instructions for assembling and attaching the Safety Ladder to the Storage Wall.



General Information

The Lista Safety Ladder provides for easy and secure access to all drawers, shelves, and roll-out trays in the upper sections of the Storage Wall. When not in use, the ladder folds flat against the Storage Wall to keep the aisle clear. When the Safety Ladder is in its folded position, it requires 12 ½" (320mm) of aisle space. The open position requires a minimum of 35 ½" (903mm) of aisle space but more space should be allowed for pedestrian traffic.

The Safety Ladder can be swiveled left or right to access any part of the Storage Wall. Ball-bearing rollers at the top, and guide rollers at the bottom allow the ladder to be manually moved along the entire length of the Storage Wall.

Important

If your Storage Wall includes both a Safety Ladder *and* Sliding Doors, you will need to attach the Extension to the T-Mast. Refer to "Attaching the Extension to the Safety Ladder" on page 3-6 for instructions.

Installing the Tracks and T-Mast

The following table provides step-by-step instructions for installing the Upper and Bottom Tracks and T-Mast to the Storage Wall.

Installing the Upper Track		
Step	Action	(Refer to Figure Chapter 3 -1)
1	Using a 5/16" Hex Head bolt and nut, install the angle bracket on top of the Storage Wall in the slot provided in the Vertical Side Frames.	
2	Place all Upper Track sections (approximately 9' long (2740mm)) on top of the Storage Wall against the Angle Brackets. Loosely secure the track to the Angle Brackets using 5/16 x 1/4" Hex Head bolts. <i>Do not fully tighten the Upper Track section at this time.</i>	
3	Insert a bumper into one end of the Upper Track to prevent the T-Mast from rolling out.	
4	Place the T-Mast so that the grooved rollers glide over the rail on the Upper Track. (The T-Mast hangs on the Upper Track) Release the Hand Brake by pushing the handle down so that the ball-bearing rollers on the top run smoothly. Insert the remaining bumper onto the other end of the Upper Track.	
5	Roll the T-Mast along the entire length of the Upper Track section to make sure it rolls freely. Adjust the Upper Track if necessary, then tighten all 5/16" Hex Head bolts on top.	
Installing the Bottom Tracks		
Step	Action	(Refer to Figure Chapter 3 -2 and Figure Chapter 3 -3)
1	Hold the Bottom Track against the Vertical Side Frames on the Storage Wall. Mark the location of the holes to be drilled in each Bottom Track and Vertical Side Frame. <i>Note: Make sure that the hole location is in the center of the Vertical Side Frame, as shown.</i>	
2	Drill 3/8" holes into the track <i>and</i> Vertical Side Frames.	
3	Attach the Bottom Tracks to the Vertical Side Frames using 5/16" Hex Head bolts and nuts. Hand-tighten. If the Bottom Track is to be joined, cut the track so that the end is in the center of the Vertical Side Frame. Mark and drill two 3/8" holes (one for each end of the adjoining tracks) and loosely secure with 5/16" Hex Head bolts and nuts.	
4	Make sure that the entire length of the Bottom Track is level. If necessary, use metal shims to adjust the level.	
5	Once the Bottom Track is level, securely tighten all M8 Hex Head bolts and nuts so that the bottom glides of the T-Mast are firmly in place.	
Installing the Safety Hooks		
Step	Action	(Refer to Figure Chapter 3 -1)
1	Install the Safety Hooks on the upper left and right ends of the T-Mast so that the hook is <i>behind</i> the Upper Track.	
2	Release the Hand Brake by pushing the brake handle <i>down</i> . Test the mobility of the T-Mast to ensure that it rolls freely and evenly across the entire length of the Storage Wall. Inspect and adjust the Bottom Track if necessary.	
3	Make sure all Hex Head bolts and nuts are securely tightened to prevent misalignment.	

Figure Chapter 3 -1 Upper Track Components

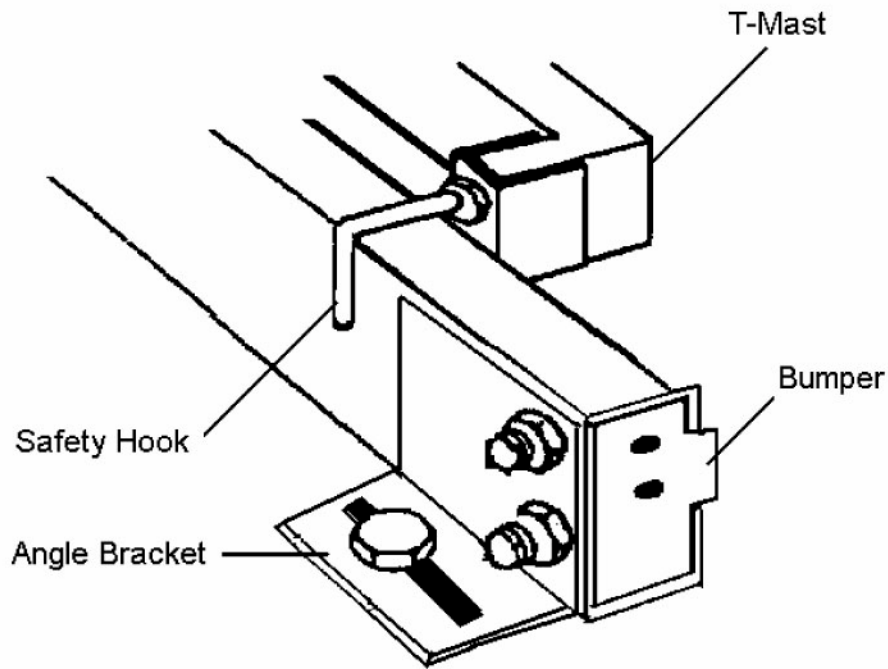

Figure Chapter 3 -2 Bottom Track

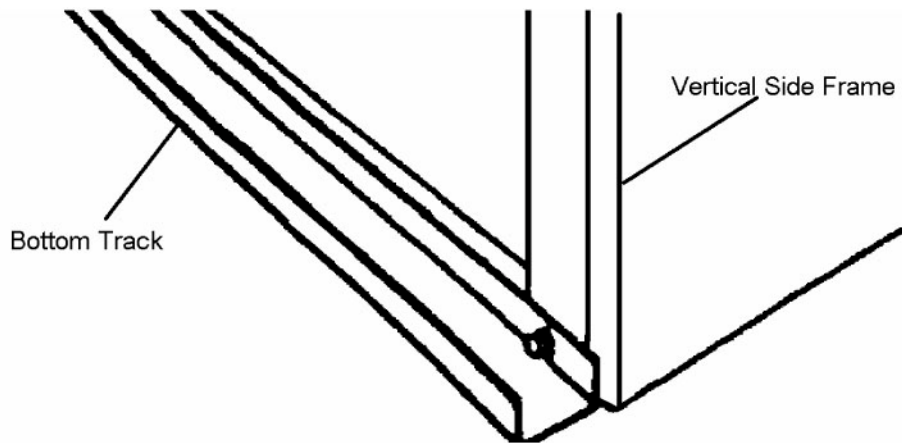
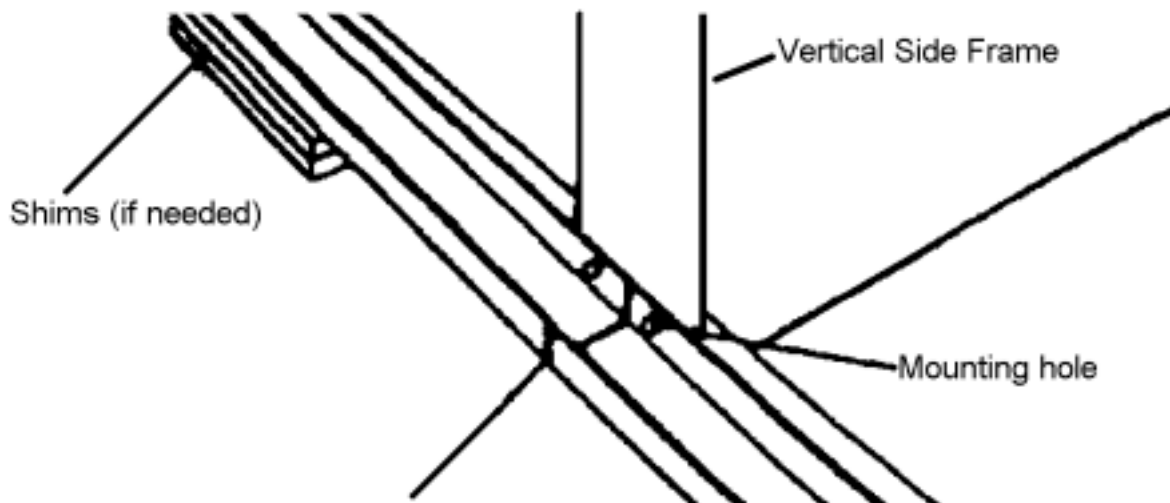

Figure Chapter 3 -3 Bottom Track Joint



Attaching the Folding Steps to the T-Mast

Lista completely assembles the Folding Steps at the factory. It is important to keep all the strapping material in place as it is received to ease handling during installation.

Attaching the Folding Steps to the T-Mast	
Step	Action (Refer to Figure Chapter 3 -4 and Figure Chapter 3 -5)
1	Using a 19mm Socket wrench, remove the two bolts from the Swivel Supports on the front of the T-Mast. Remove the Plated Shaft.
2	Insert the Plated Shaft into the Swivel Cylinder (attached to the Folding Steps). Slide the Ladder (with the Plated Shaft in place) in between the Swivel Supports on the T-Mast.
3	Insert the top and bottom 19mm Hex Head bolts through the Swivel Supports and into the Plated Shaft. Tighten securely using a 19mm Socket wrench.
Attaching the Handle	
Step	Action
1	Insert the spring-loaded Brake Handle above the Swivel Support using M8 x 10 Hex Head bolts. Tightly secure using a 13mm Socket wrench.
2	Mount the Swivel-Control Handle using the roll-pin and C-clip retainer.
Note: The Handle locks the Safety Ladder in place. Push the Handle down to change positions.	
3	With the Safety Ladder in the locked position (steps folded), cut the strapping material.
4	With the brake engaged, push the Safety Ladder to the left and right. The ladder should not move. Push the Brake Handle down and ensure that the lower and upper brakes release.

Operating the Safety Ladder

The following table describes how to open and close your Safety Ladder.

If you want to:	Then do this:
Open the Steps (in either direction)	Pull the black knob down to release the locking mechanism, then push the bottom step down.
Close the Steps	Pull the black knob down and push the bottom step with your foot.
Position the Ladder Left or Right	Push the Swivel Control Handle down and swing the ladder.
Move the Ladder along the Storage Wall	Push the Brake Handle down and move the ladder to the desired location, release the Brake Handle. Lista recommends that you get off of the ladder before attempting to move it to a new position.

Figure Chapter 3 -4 T-Mast Swivel Support

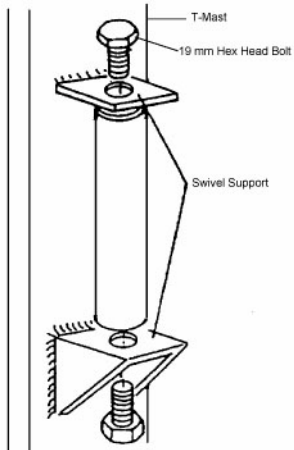
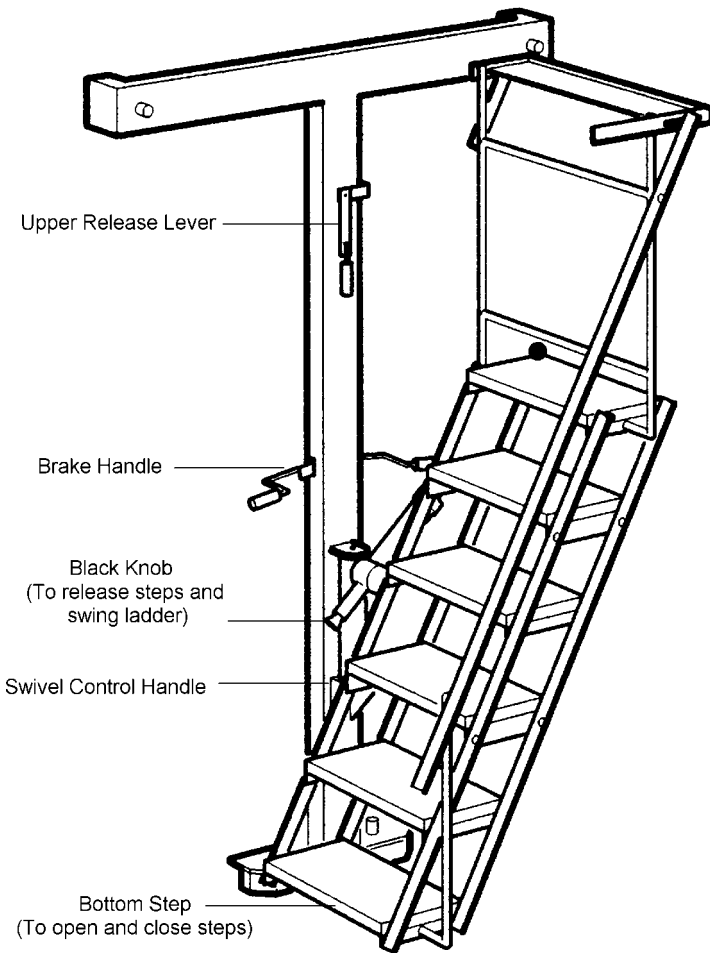

Figure Chapter 3 -5 Safety Ladder Components



Attaching the Extension to the Safety Ladder

If your Storage Wall includes both a safety ladder *and* sliding doors, you will need to attach the extension to the ladder's T-mast to provide enough room to access the sliding doors. Perform the following steps to attach the extension to each side of the T-Mast.

Step	Action	Refer to Figure Chapter 3 -6
1	Transfer the grooved wheels ⑤ from the original ladder on to the Extension ② as shown, making sure you assemble all of the hardware in the same sequence as you disassembled from the original ladder.	
2	Transfer the security hook ⑨ from the original ladder onto the Extension ②	
3	Attach the Extension sub-assembly to the T-Mast as follows: <ul style="list-style-type: none"> • Slide the Sleeve (#10) over the shaft inside the Extension tube and fasten with a washer (#11), Security Washer ⑥, and M10x25 Hex Head bolt ⑦. • Insert the M10x15 Hex Head bolt (#13), security washer ⑥, and washer (#12) into the second hole inside the Extension tube. 	
4	Remove the brake pad from the original ladder (#16) and attach it to the Brake Extension (#15). Attach the original brake pad to the Brake Extension using M5x16 Socket Cap screws (#14).	
5	Snap the Extension covers ③ onto the bottom of both Extensions ②.	
6	Slide the Ladder (wheels) onto the Ladder Tracks from either side.	
<i>Note: If necessary, adjust the brake pad so that the ladder flows easily along the track.</i>		
7	Adjust the safety hook ⑨ and secure with an M10 Hex nut ⑧ from behind the T-Mast.	
8	Attach the End Stops to the upper and lower tracks.	

Maintaining the Safety Ladder

Perform the following steps periodically to maintain the Safety Ladder:

- Make sure that both the Upper and Bottom Tracks are clean. There should be no dirt, rags, metal fillings, parts, or other debris in the track.
- Lubricate the Ladder Control Piston Handle shaft with a common lubricant to ensure free movement.
- Check the Upper and Lower T-Mast brakes and replace the brake pads if worn. Contact Lista (1-800-722-3020) to order new brake pads.
- Check all bolts and nuts (including the Bumpers and Safety Hooks) to make sure they are tight.
- Clean the T-Mast and steps with a common cleaner.

Figure Chapter 3 -6 Safety Ladder Extension Assembly

