

Assembly and Use Instructions for: FlexWorks Accessories System FlexWorks FloorStand

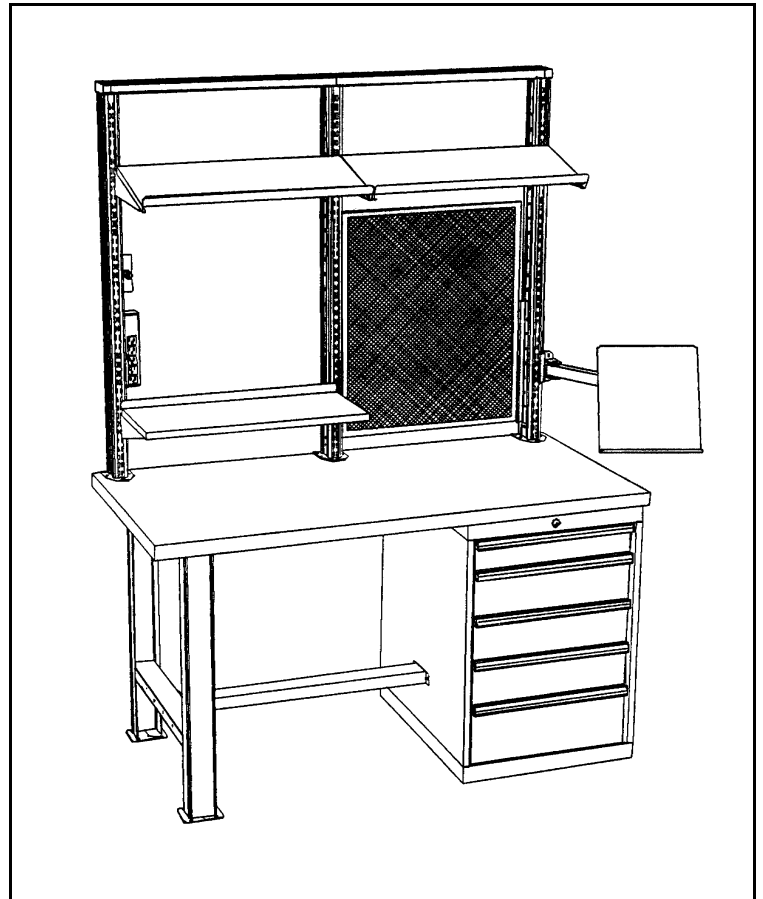
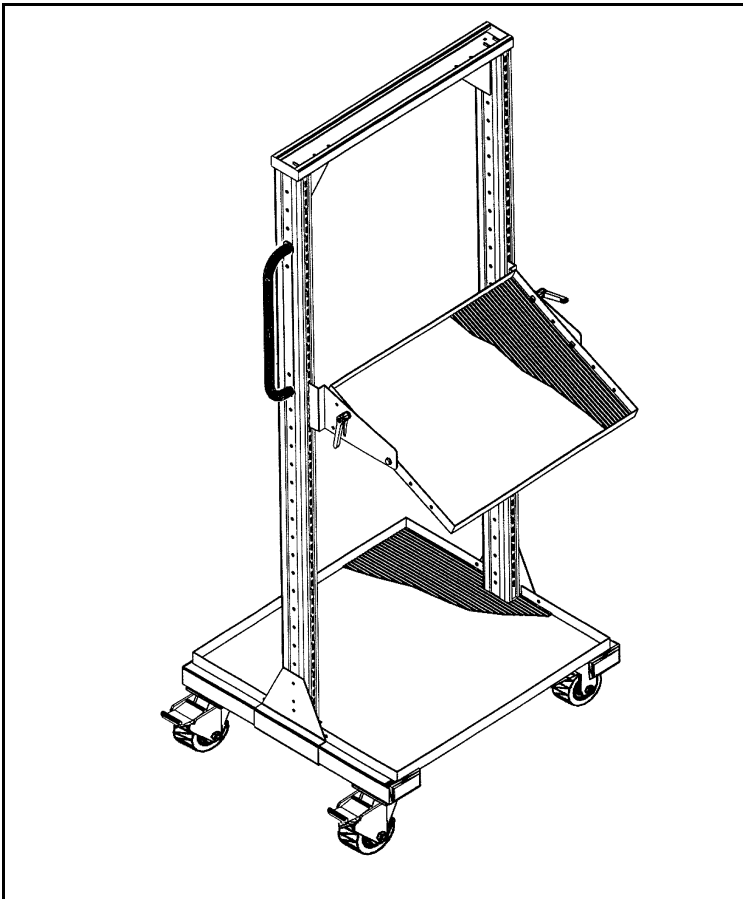

Table of Contents

Chapter 1	
Installing Starters/Adders	1_1 – 1_5
Chapter 2	
Assembling FlexWorks FloorStand	2_1 – 2_4
Chapter 3	
Installing FlexWorks Accessories	3_1 – 3_13

Chapter 1 - Installing FlexWorks Starters/Adders to Workbenches

SAFETY PRECAUTIONS

READ THESE ASSEMBLY AND USE INSTRUCTIONS PRIOR TO ASSEMBLING ANY FLEXWORKS PRODUCTS

WORK SURFACE MUST HAVE A WOOD CORE THAT IS 1.25" THICK TO SAFELY ATTACH FLEXWORKS UPRIGHTS

WORKBENCH SHOULD BE LEVEL SIDE TO SIDE AND FRONT TO BACK

UPRIGHTS MUST BE MOUNTED AT LEAST 1" FROM EDGE OF WORKBENCH

MAXIMUM LOAD CAPACITY OF ANY FLEXWORKS SHELF OR SWING ARM ACCESSORY IS 50 LBS.

REQUIRED TOOLS

Sockets or Open End Wrenches

3/8" drive with 3" to 6" extension

1/2" Socket or open end wrench

7/16" Socket or open end wrench

9/16" Socket or open end wrench (for assembling and attaching optional accessories)

Allen Wrench Set

Screwdrivers

#2 Phillips Head Screwdriver

Flat Head Screwdriver

Drill Bits #7 (.200" or 5.1mm) Drill Bit

General Tools

Center Punch

Electric Hand Drill

Rubber Mallet

Measuring Tape

Attaching Starters and/or Adders to WorkBench

This chapter provides step-by-step instructions for attaching a FlexWorks® Starter and/or Adders to your workbench. A Starter consists of two Uprights and a Cross Member and can stand by itself on top of the workbench. The Adder is a unit consisting of one Upright and one Cross Member that can be attached to the Starter and to itself an infinite number of times. Instructions for mounting rear-mount FlexWorks are also included. You must have a Lista workbench designed to use rear-mount FlexWorks.

Mounting the Starter and/or Adders

Lista provides templates to ensure an exact measurement for mounting the Cross Member and Uprights. Refer to Table 1 - 2 to determine the mounting dimensions for your work surface. Figure 1 -2 shows an illustration of the templates.

Using the Templates to Mark Hole Patterns for Drilling (See Figure 1-2)

- 1 Clip the Templates to the Cross Member to locate the position of each Upright on your work surface. 2 With the Templates and Cross Member located in the proper installation position, mark hole patterns of each Template with a pencil. Repeat for each Starter and/or Adder section. Make sure the locations are correct before actually drilling the holes.
- 3 Use a #7 (.200" or 5.1mm) Drill Bit to drill mounting holes for maple, plastic or Lista tops.



CAUTION

THESE INSTRUCTIONS APPLY TO MOUNTING THE FLEXWORKS ACCESSORY SYSTEM TO A LISTA PROVIDED WORKSURFACE. USERS SHOULD BE SURE THAT WORKSURFACES FROM OTHER VENDORS MEET THE MINIMUM SCREW-HOLDING FORCE AS SPECIFIED PER AMERICAN NATIONAL STANDARD FOR INDUSTRIAL PARTICLEBOARD GRADE M2.

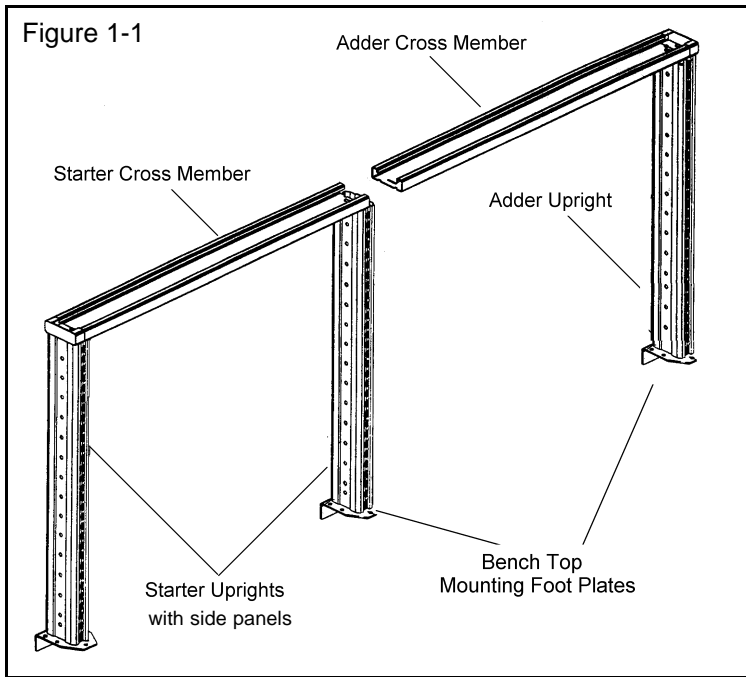

Table 1-1 FlexWorks Frame Components List

Starter Set		
<u>Description</u>	<u>Quantity</u>	<u>Part Number</u>
Uprights (with factory installed side panels)	2	Varies/height
Cross Member	1	
Phillips Head Round Screws ¼ - 20 x ½ "	12	100318
Hex Head Flange Screws 5/16 x 1¼"	12	112049
Splicer for Cross Member	2	108159
Socket Head Cap Screws ¼ - 20 x ¾"	4	108172
Adder Set		
<u>Description</u>	<u>Quantity</u>	<u>Part Number</u>
Uprights w/ covers	1	Varies/length
Splicer for Cross Member	1	108159
Hex Head Flange Screws 5/16 x 1¼"	6	112049
Socket Head Cap Screws ¼ - 20 x ¾"	2	108172

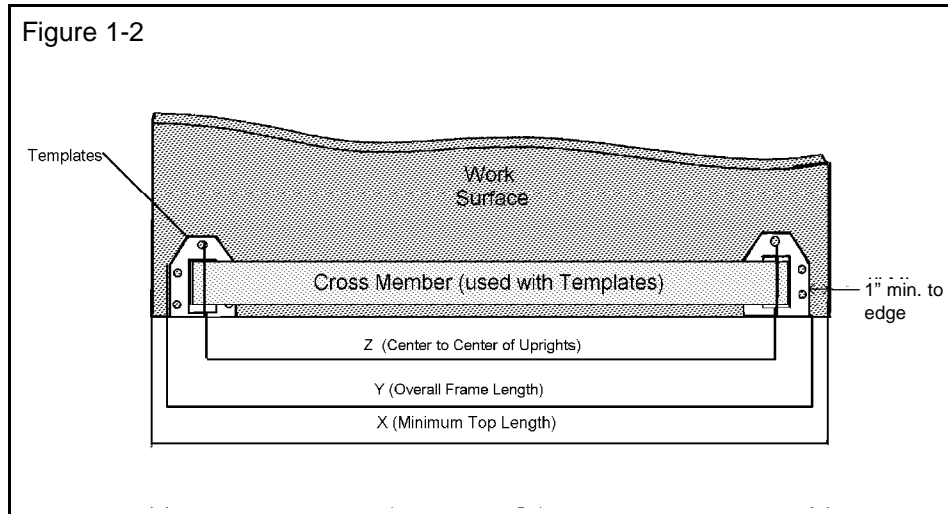

Table 1-2 Determining Starter/Adder Placement

Starter/Adder Types	Minimum Top Length "X"	Overall Frame Length "Y"	Center to Center of Uprights "Z"
21	26.75" (679.45mm)	24.75" (628.65mm)	21.25" (539.75mm)
27	32.75" (831.85mm)	30.75" (781.05mm)	27.25" (692.15mm)
33	38.75" (984.25mm)	36.75" (933.45mm)	33.25" (844.55mm)
39	44.75" (1136.65mm)	42.75" (1085.85mm)	39.25" (996.95mm)
45	40.75" (1289.05mm)	48.75" (111238.25mm)	45.25" (1149.35mm)

Attaching the Uprights to your Work Surface (See Figure 1-3)

- 1 Attach the Upright ① to the work surface by inserting 5/16 x 1¼" Hex Flange Screws ③ down through the Foot Plates ② and into the predrilled holes in the workbench top.

Attaching the Cross-Member to the Uprights (See Figure 1-4)

- 1 Align the hole patterns of the Cross Member ① with the hole patterns on the top of each Upright.
- 2 Insert the End Cap ④ onto the end of the Cross Member ①.
- 3 Place the Splicers ② over the hole patterns.
- 4 Insert two ¼ - 20 x ¾" Socket Head screws ③ down through the Splicers ② and into the hole patterns of the Cross Member ① and Uprights.
- 3 Tightly secure the ¼ - 20 x ¾" Socket Head screws ③.

Assembling Rearmount FlexWorks for Height-Right® Workbenches

Attaching the Uprights (See Figure 1–5)

- 1 Align the Mounting Bracket ① with the four holes at bottom of Upright ②. Repeat for each Upright and Mounting Bracket.

Note: Mounting Bracket lances must face down, toward the bottom of the upright.

- 2 Insert four 5/16 x 3½" Socket Cap Screws ③ through the back of the Upright and into the Mounting Bracket ①. Tightly secure with four Square nuts ④. Repeat for each Upright.
- 3 Loosely secure two Anchor Plates ⑤ to the Mounting Bracket ① with four 5/16" Hex Head bolts ⑥. Repeat for each Mounting Bracket and Upright assembly.
- 4 Remove the End Caps ⑦ from the FlexWorks Support Panel ⑧.
- 5 Slide each Upright assembly into the FlexWorks Support Panel ⑧. Position each Upright assembly into its approximate location on the workbench.
- 6 Attach cross members as described in paragraph above.

Note: Uprights must be parallel to each other for FlexWorks accessories to properly fit. Measure the inside distance between the uprights at the top of each upright. Then measure the bottom to verify that the distances are equal.

- 7 Tightly secure each upright bracket before installing FlexWorks accessories. (See Chapter 3)

Figure 1-3

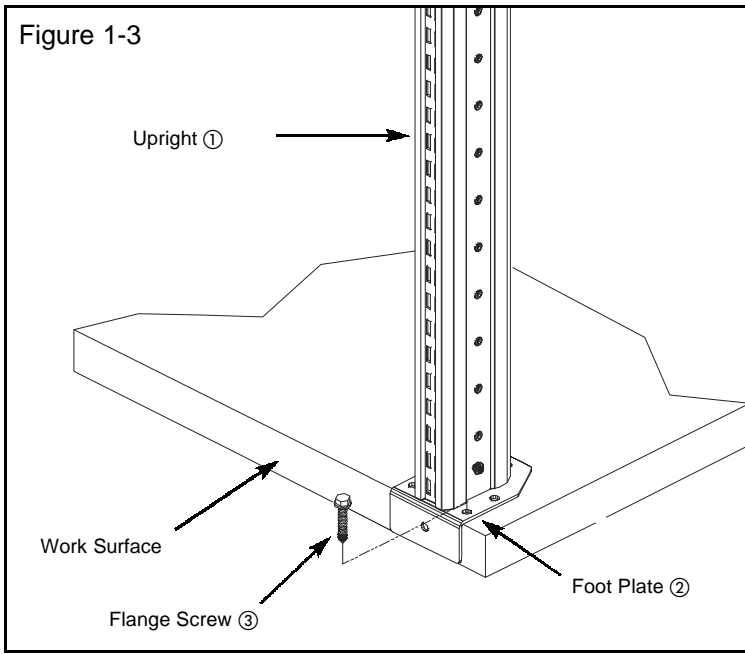

Figure 1-4

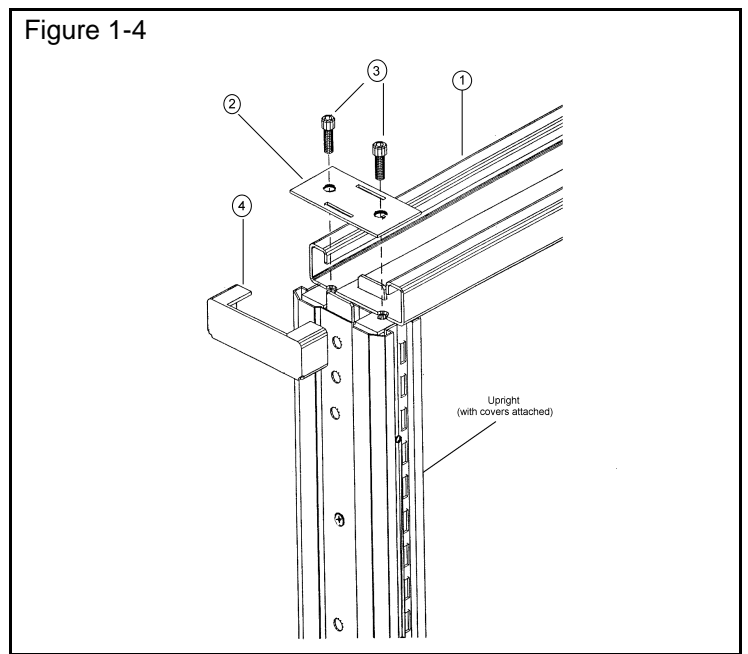

Figure 1-5

