



Align™ Hand Crank Base Adjustable Height Workbench

Instructions for Assembly

formerly Ergomation EDG workbench

Center Justified

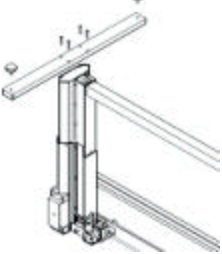
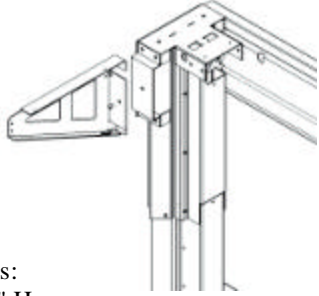
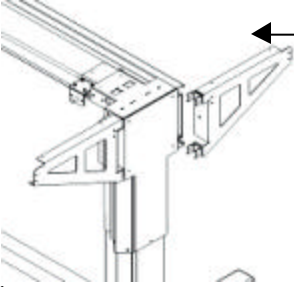
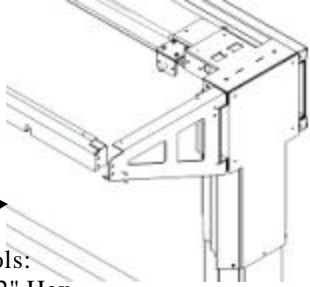
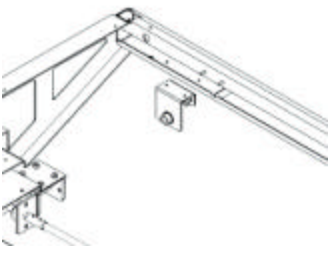
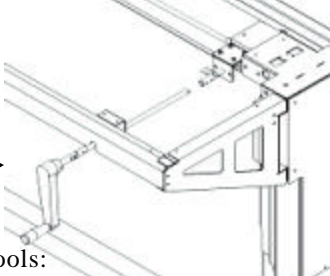
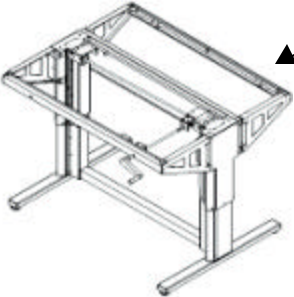
 <p>Tools: 3/16" Hex</p>	<p>STEP 1</p> <ol style="list-style-type: none"> Attach foot to leg using (4) 5/16"-18 x 2" screws. Thread levelers into foot. Repeat to other leg. <p>STEP 2</p> <ol style="list-style-type: none"> Attach side bracket using (3) 5/16"-18 x 5/8" screws. Repeat to other side. 	 <p>Tools: 3/16" Hex</p>
 <p>Tools: 3/16" Hex</p>	<p>STEP 3</p> <ol style="list-style-type: none"> Attach BRKT2001 to side bracket using (2) 5/16"-18 x 5/8" screws. Slide BRKT2001 into chase of fixing frame and tighten. <p>STEP 4</p> <ol style="list-style-type: none"> Attach front deck tube to side bracket using (2) 1/4"-20 x 5/8" and (2) 1/4"-20 kep nuts. Repeat to back side. 	 <p>Tools: 5/32" Hex 7/16" Wrench</p>
 <p>Tools: (2) 7/16" Wrenches</p>	<p>STEP 5</p> <ol style="list-style-type: none"> Attach crank bracket to front deck tube using (2) 1/4"-20 x 1/2" screws and (2) 1/4"-20 kep nuts. <p>STEP 6</p> <ol style="list-style-type: none"> Attach coupling to crank gear box using a 5/32" roll pin. Slide crankshaft with handle through the bracket in step 5. Attach crankshaft to coupling with 5/32" roll pin. 	 <p>Tools: Hammer Needle Nose Pliers</p>
	<p>Completed View</p>	

Tools Required

- 3/16" Hex
- 5/32" Hex
- (2) 7/16" Wrenches
- Hammer
- Needle Nose Pliers

Rear Justified

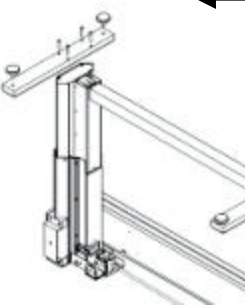
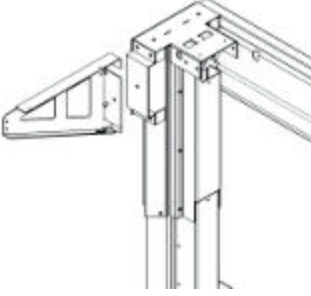
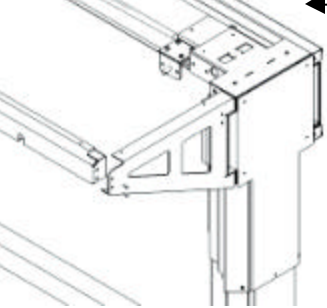
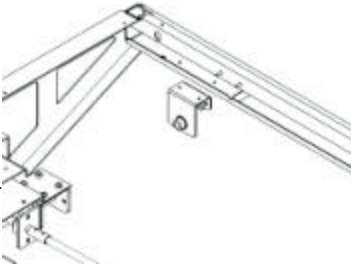
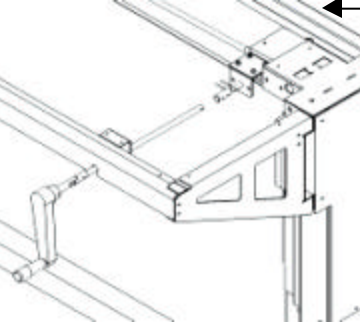
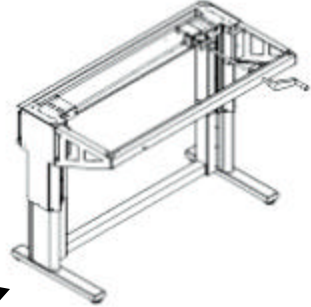
 <p>Tools: 3/16" Hex</p>	<p>STEP 1</p> <ol style="list-style-type: none"> Attach foot to leg using (4) 5/16"-18 x 2" screws. Thread levelers into foot. Repeat to other leg. <p>STEP 2</p> <ol style="list-style-type: none"> Attach side bracket using (3) 5/16"-18 x 5/8" screws. Repeat to other side. 	 <p>Tools: 3/16" Hex</p>
 <p>Tools: 5/32" Hex 7/16" Wrench</p>	<p>STEP 3</p> <ol style="list-style-type: none"> Attach front deck tube to side bracket using (2) 1/4"-20 x 5/8" and (2) 1/4"-20 kep nuts. Repeat to other side. <p>STEP 4</p> <ol style="list-style-type: none"> Attach crank bracket to front deck tube using (2) 1/4"-20 x 1/2" screws and (2) 1/4"-20 kep nuts. 	 <p>Tools: (2) 7/16" Wrenches</p>
 <p>Tools: Hammer Needle Nose Pliers</p>	<p>STEP 5</p> <ol style="list-style-type: none"> Attach coupling to crank gear box using a 5/32" roll pin. Slide crankshaft with handle through the bracket in step 4. Attach crankshaft to coupling with 5/32" roll pin. <p>Completed View</p>	

Tools Required

- 3/16" Hex
- (2) 7/16" Wrenches
- Hammer
- Needle Nose Pliers
- 5/32" Hex
- 7/16" Wrench



Align™ is a trademark of Lista International Corporation.
Making Workspace Work® is a trademark of Lista International Corporation.

Print Date: June 2004

This manual is proprietary information of Lista International Corporation. Unauthorized reproduction of any portion of this manual is prohibited without the written consent of Lista International Corporation. The material in this manual is for informational purposes only. It is subject to change without notice. Lista International Corporation assumes no responsibility for any typographical errors contained in this manual.

© 2004 by Lista International Corporation, all rights reserved
106 Lowland Street
Holliston, MA 01746-2094
E-mail: sales@listaintl.com

All rights reserved.

For questions or technical support, call **1-800-722-3020**

ISO 9001 Certified