

COMPLETE TOW HITCH KIT ASSEMBLY

PARTS LIST FOR 35020, 35021 AND 35022 FULL INSTALLATION KITS

Item	Description	Qty for 36" Long Dolly	Qty for 42" Long Dolly	Qty for 48" Long Dolly	Part No.
A	Hitch bracket with pin	1	1	1	35018
B	Center support brace:				
	For 36" long dollies	1	-	-	35005
	For 42" long dollies	-	1	-	35006
	For 48" long dollies	-	-	1	35007
C	Tow arm assembly	1	1	1	35019
D	Hex head cap screw - 3/8"-16 x 1-1/4" long	4	4	4	80026
E	Hex lock nut - 3/8"-16	4	4	4	80603

TOOLS REQUIRED

- (1) PENCIL, MARKER OR TRANSFER PUNCHES
- (1) HAMMER
- (1) PISTOL DRILL
- (1) .406Ø DRILL BIT
- (2) 9/16" SOCKETS AND/OR WRENCHES

Use this bracket as a template for drilling holes into the frame. Below is the correct bracket orientation (U-notches face up).

Center the bracket vertically and horizontally and mark hole placement. Drill holes; repeat on other end.

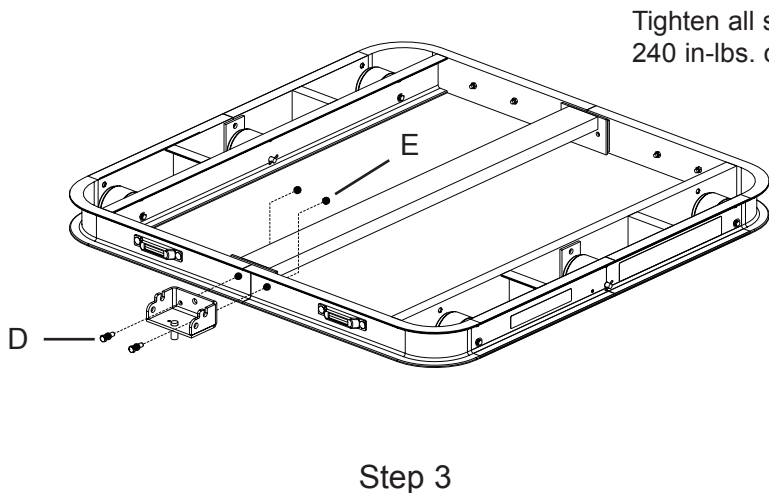
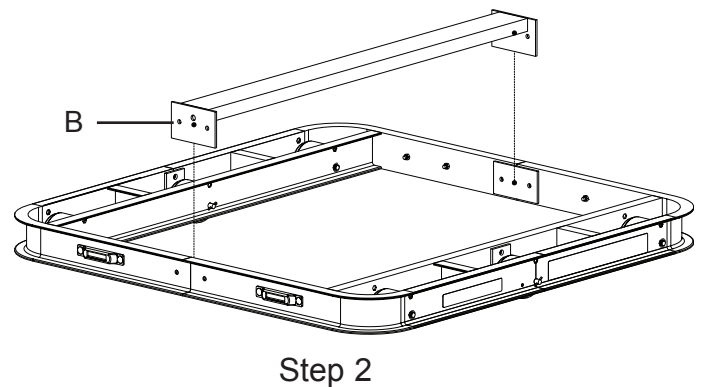
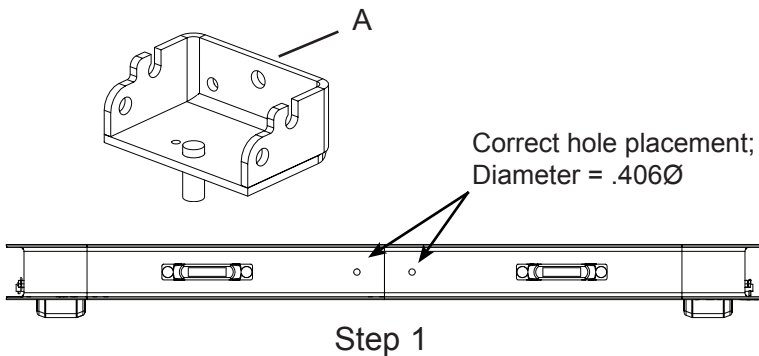

Tighten all screws to 240 in-lbs. of torque.

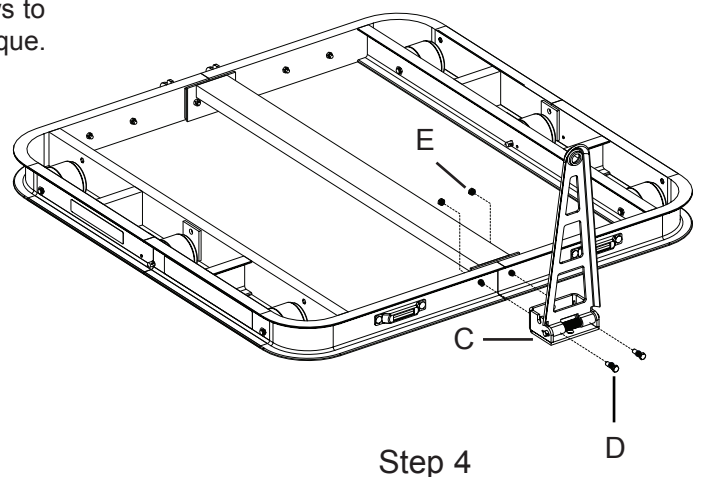

MANUAL HANDLE KIT ASSEMBLY

PARTS LIST FOR 35023 MANUAL HANDLE ONLY KIT

Item	Description	Qty	Part No.
A	Hitch bracket	1	35015
B	Hex head cap screw - 3/8"-16 x 1-1/4" long	2	80026
C	Hex lock nut - 3/8"-16	2	80603
D	Handle with grips	1	35014

TOOLS REQUIRED

- (1) PENCIL, MARKER OR TRANSFER PUNCHES
- (1) HAMMER
- (1) PISTOL DRILL
- (1) .406Ø DRILL BIT
- (2) 9/16" SOCKETS AND/OR WRENCHES

The handle can be used on pallet dollies that already have the tow hitch installed and the handle can be ordered individually. Use these instructions if you are retrofitting a pallet dolly without the tow hitch option.

Use the bracket as a template for drilling holes into the frame. This is the correct bracket orientation (U-notches face up).

Center the bracket vertically and horizontally and mark hole placement. Drill holes. Tighten screws to 240 in-lbs. of torque.

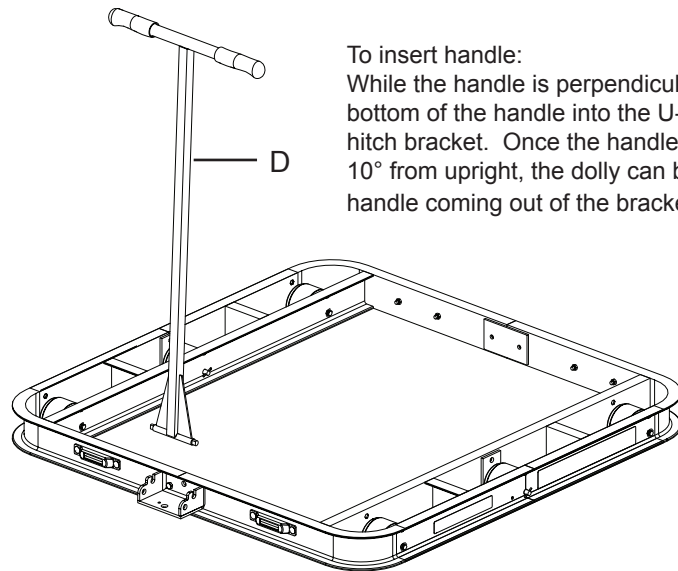
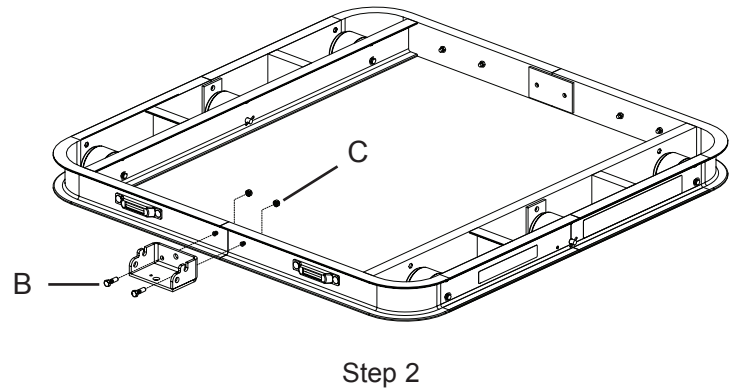
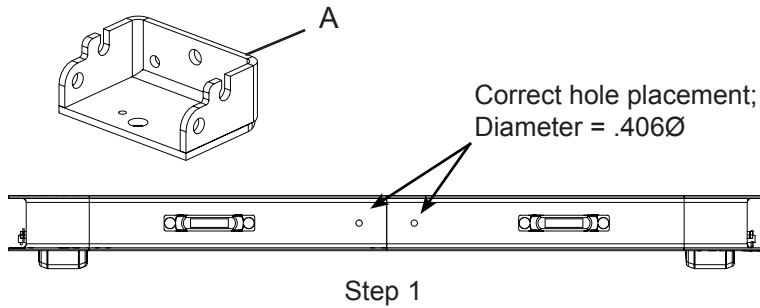

To insert handle:

While the handle is perpendicular to the ground, insert the bottom of the handle into the U-shaped notches located in the hitch bracket. Once the handle is moved forward or backward 10° from upright, the dolly can be maneuvered without the handle coming out of the bracket.

To remove handle:

Move the handle so that it is completely upright and perpendicular to the ground; lift straight up to remove from bracket.

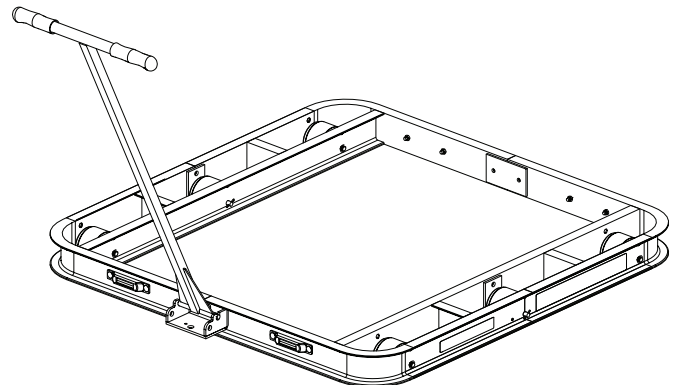

Handle/bracket interlock

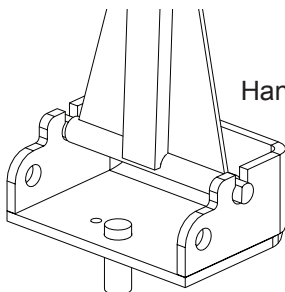

MAGLINE, INC.

1205 W. Cedar Street • Standish, MI 48658 USA
 1-800-MAGLINE (624-5463) • (989) 512-1000 (outside U.S. & Canada)
www.magliner.com