

Raise, Transport, Rotate and Drain Drum

- Use as a drum truck, drain stand, dolly or pump cart
- Self Supporting once loaded - There is no weight in the operator's hands
- When unlocked, tilt your drum to any angle or turn 360° to agitate
- Lock your drum at horizontal to drain
- Lock your drum upright to prevent spills
- Leverage for up to an 800 Lb. (363 kg) drum
- Rolls and steers easily
- Variable lift heights



Model 80A shown

Mobile-Karrier is More than a Drum Truck

It is a drum handler with many features that make it more versatile and convenient!

It supports the full weight of your drum and transports it upright to avoid spills. Automatic handle-locks are designed to prevent unintentional lowering of the drum. Tilt-locks on each side may be used to keep the drum upright or horizontal. Unlocked, the drum may be turned end-over-end to agitate contents, or may be tipped at an angle for draining. Locked at horizontal, the drum can remain ready for dispensing.

Morse Mobile-Karriers are extremely easy to maneuver on 8" (20.3 cm) hard, "MORTUF" polyolefin roller bearing wheels and 4" (10.2 cm) ball-bearing swivel caster. The frame is welded structural steel for long service. You can be assured that Morse quality is built-in when you see the Morse name cut into the solid steel drum holder.

Made at our factory in East Syracuse, New York U.S.A. and shipped partly assembled in a durable carton to save you freight costs.



High Strength Lifting Components

Mobile-Karriers use high strength lifting components.

The solid steel band around the drum has the Morse name boldly cut through it, permanently identifying it as a genuine quality Morse product.

Morse models 80A, 80AM and 80APS have high strength, wear resistant cinch chain to secure the drum. The chain tightening ratchet and spring loaded pawl assembly has been designed with oversize, specially contoured teeth and redundant safety features for reliability and ease of use.



Model	Description	Handle Types of Drums	Domestic	
			Ship Weight	Ship Dimensions
80A	Mobile-Karrier with cinch chain drum holder	Steel 55-gallon drum 22.5" diameter between ribs	95 Lb. (43 kg)	41" x 36" x 9" (104 x 91 x 23 cm)
80AM	Mobile-Karrier with cinch chain drum holder and spark resistant parts	Steel 55-gallon drum 22.5" diameter between ribs	97 Lb. (44 kg)	41" x 36" x 9" (104 x 91 x 23 cm)
80APS	Mobile-Karrier with cinch chain drum holder for 55-gallon plastic or steel drum	55-gallon plastic drum 22.5" to 24" (57 to 61 cm) diameter, 34" to 36" (86-92 cm) tall. Also standard steel 55-gallon drum.	97 Lb. (44 kg)	41" x 36" x 9" (104 x 91 x 23 cm)



morsedrum.com



service@morsedrum.com



(315) 437-8475



727 West Manlius St.
East Syracuse, NY, 13057 USA

One Person Can Handle a Heavy Drum

- **Advanced design with improved safety features.**
- **Simple to lift, move, tilt, agitate and drain heavy drum!**

Adjustable Leverage

You adjust the Morse Mobile-Karrier to do your job with minimum effort. Adjust to accommodate drum weights up to 800 Lb. (363 kg) and floor clearances of 5-1/8" to 11" (13 to 27.9 cm). Tipping capacities vary with type and amount of load carried.

Morse Drum Holders for Various Drums Sizes

Saddle type A fits a standard 55-gallon (210 liter) steel drum, and is included in the Morse model 80A and 80AM Mobile-Karriers.

Model with Spark Resistant Parts

Morse drum handlers normally have steel structure, but spark resistant models are made with Monel drum band. The letter "M" in model 80AM designates the unit is made with spark resistant parts. Stainless steel cinch chain replaces the standard steel chain.



1.
**Model 80A
shown**

1. IT'S SIMPLE TO SECURE THE DRUM

Roll the Mobile-karrier forward and push the drum holder into the center of the drum. The extra strength cinch chain is easily secured across the front of the drum with the ratchet tightener. No tools are necessary.

2. JUST PULL DOWN THE HANDLE TO RAISE DRUM

The drum is then raised by squeezing the two handle release rods and pulling the handle down. Automatic locks engage to hold drum up as handle is lowered. Tilt locks hold drum upright.



2.



3.

3. EASY TO MOVE WITHOUT SPILLING CONTENTS

With the Mobile-Karrier supporting the load, the operator can quickly and easily move it to dispensing area. Drum should always be transported in vertical position to avoid spilling.

4. YOU CAN DISPENSE FROM ANY POSITION

Tilt locks can be reset to automatically secure the tilted drum at horizontal for dispensing, or allow it to be turned as far as desired. Mobile-Karrier may be left holding drum for subsequent dispensing, or the drum may be easily returned to storage, freeing the Mobile-Karrier for handling other drums.

Model 80A, 80AM and 80APS have tilt locks for upright and horizontal positions only.



4.

MADE
IN
USA

DIMENSIONS

FOR DRUM WITH 22-1/2" (57.2 cm) DIAMETER, 36" (91.4 cm) TALL

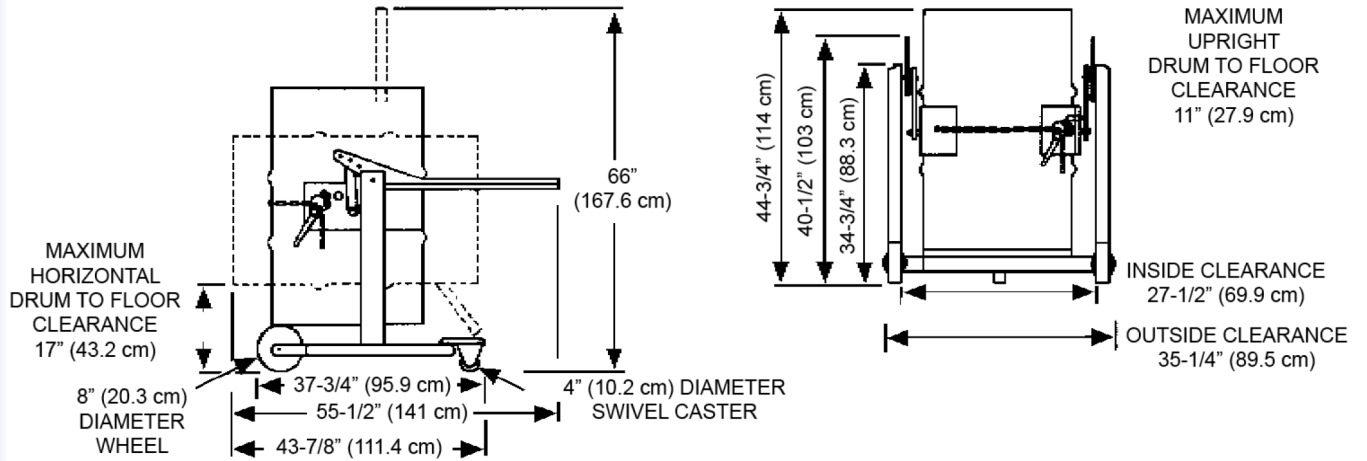

MADE
 IN
 USA