

Operator's Manual for Morse Stainless Steel Rim Clamp Assembly Kit

Part # 4560SS-P

Serial Number 0711 to ____ (MMYY)

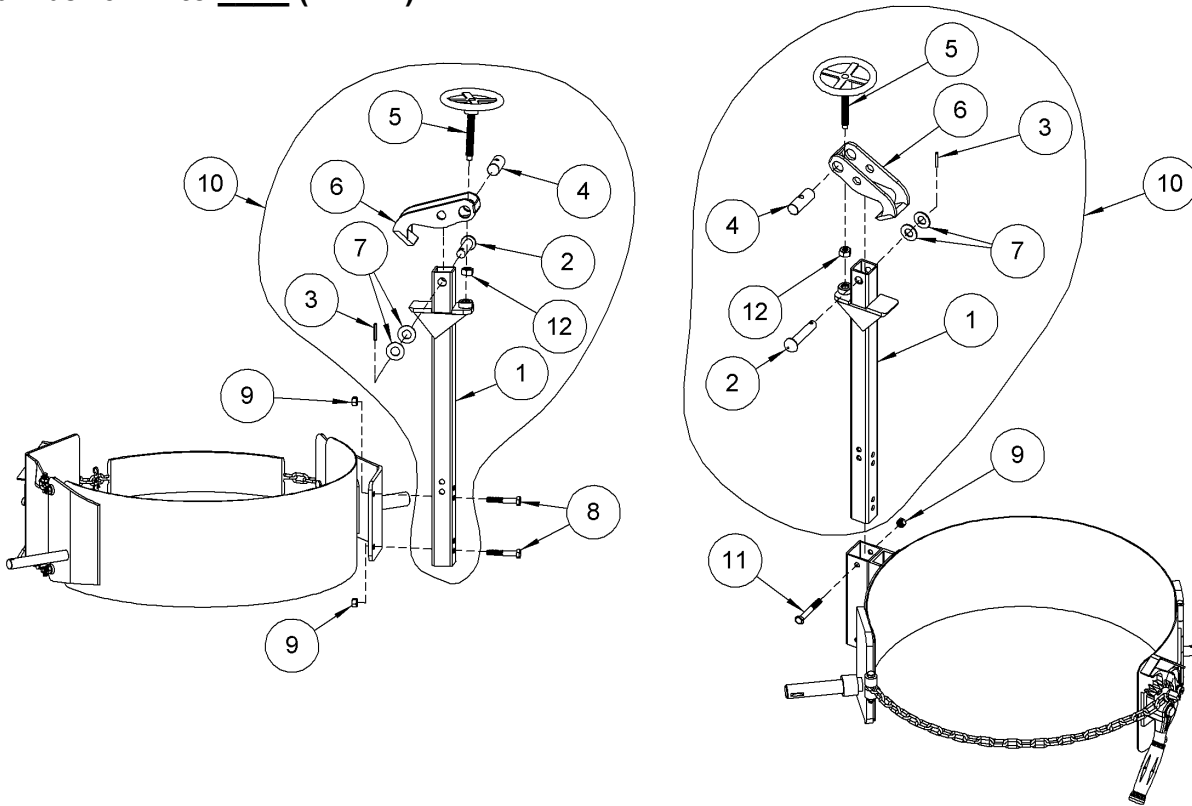

INSTALLATION INSTRUCTIONS
for MORcinch Drum Holder

1. Attach Rim Clamp Assembly (item 10) to drum holder bracket.
2. Line up rim clamp with holes of drum holder bracket.
3. Bolt in place using 2 bolts (item 8) and 2 nuts (item 9).

INSTALLATION INSTRUCTIONS
for Drum Holder with Socket Tube

1. Slide Rim Clamp Assembly (item 10) down through socket tube, and line up top holes in Rim Clamp Assembly with top holes of socket tube.
2. Use bolt (item 11) and nut (item 9) to bolt in place through the top holes of the socket tube and the Rim Clamp Assembly.

ITEM	QTY	PART #	DESCRIPTION
1	1	4558SS-P	WELD, RIM CLAMP, SR
2	1	138SS-P	CLEVIS PI, 400 SS
3	1	64SS-P	ROLL PIN, 3/16 X 1-1/4, SS
4	1	3510SS-P	THREADED BARREL, RIM CLAMP, SS
5	1	3616-P	HANDWHEEL ASM, 4", 185R
6	1	3239SS-P	TOP JAW, RIM CLAMP, WELD, SS
7	2	17SS-P	WASHER, 5/8 SAE 1-5/16 OD, SS
8	2	82SS-P	HHCS, 3/8-16 X 2-1/4, SS
9	2	3981SS-P	NUT, 3/8-16 NYLON LOCK, SS
10	1	4557SS-P	ASM, RIM CLAMP, SCREW, SS
11	1	1315SS-P	HHCS, 3/8-16 X 2-3/4 GR2 SS
12	1	810SS-P	NUT, 1/2-13 NYLON LOCK, SS

Operator's Manual for Morse Stainless Steel Rim Clamp Assembly Kit

Part # 4560SS-P

Serial Number 0711 to ____ (MMYY)

OPERATING INSTRUCTIONS

TO SECURE DRUM:

1. Turn hand wheel (item 5) counter clockwise to open top jaw (item 6).
2. Position drum holder assembly with bottom jaw of rim clamp directly under top rim of drum.
3. Turn hand wheel clockwise until top jaw is pressing tightly against top of drum (see Figure 1).
4. Secure drum with chain and ratchet mechanism. Drum is now ready to be lifted and tilted.

TO RELEASE DRUM:

1. Lower drum to floor in an upright position.
2. Release chain from ratchet mechanism by applying pressure to ratchet handle in a clockwise direction with one hand and opening pawl to free ratchet with other hand. Remove chain link from ratchet.
3. Open rim clamp by turning hand wheel counter clockwise.

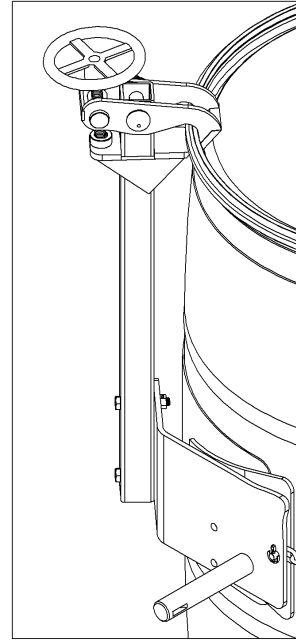

Figure 1

Plastic drum being lifted with part number 4560SS-P Rim Clamp Assembly Kit installed.