

# Inventory Cart Assembly Instructions Part No. 8767

## PARTS LIST

### Used on All Cart Sizes

#### Casters Parts

- 2 Swivel Wheel Casters with Locking Lever
- 2 Fixed Wheel Casters

- 16 Machine Bolts 5/16"-18 x 5/8"
- 16 Hex Nut 5/16"-18

- 16 Flat Washers

#### Carriage and Beam Parts

- 2 Carriages
- 2 Rivet-less Beams 36", 48" or 60" depending on width ordered (two bolt holes on each end)

- 16 Machine Bolt 1/4"-20 x 5/8"
- 16 Hex Nut 1/4"-20

- 16 Lock Washers, 1/4" External Tooth

#### Push / Pull Handle

- 1 Single Rivet Beam 24" wide

#### Upright Post

- 4 Angle Posts (48" or 60" high)
- 4 Plastic Post Caps

### 48" High Inventory Cart

#### Shelf Supports

##### Supports for Intermediate Shelf

- 2 Single Rivet Beams 24" width
- 2 Single Rivet Beams 36" or 48" depending on width ordered (60" wide carts get Double Rivet Beams instead of Single Rivet Beams)

#### Deck Material

- 3 Sheets Deck Material

##### Supports for Top Shelf

- 2 Double Rivet Beams 24"
- 2 Double Rivet Beams 36" or 48" depending on width ordered.

### 60" High Inventory Cart

#### Shelf Supports

##### Supports for 2 Intermediate Shelves

- 4 Single Rivet Beams 24" width
- 4 Single Rivet Beams 36" or 48" depending on width ordered (60" wide carts get Double Rivet Beams instead of Single Rivet Beams)

#### Deck Material

- 4 Sheets Deck Material

##### Supports for Top Shelf

- 2 Double Rivet Beams 24"
- 2 Double Rivet Beams 36", 48" or 60" depending on width ordered.

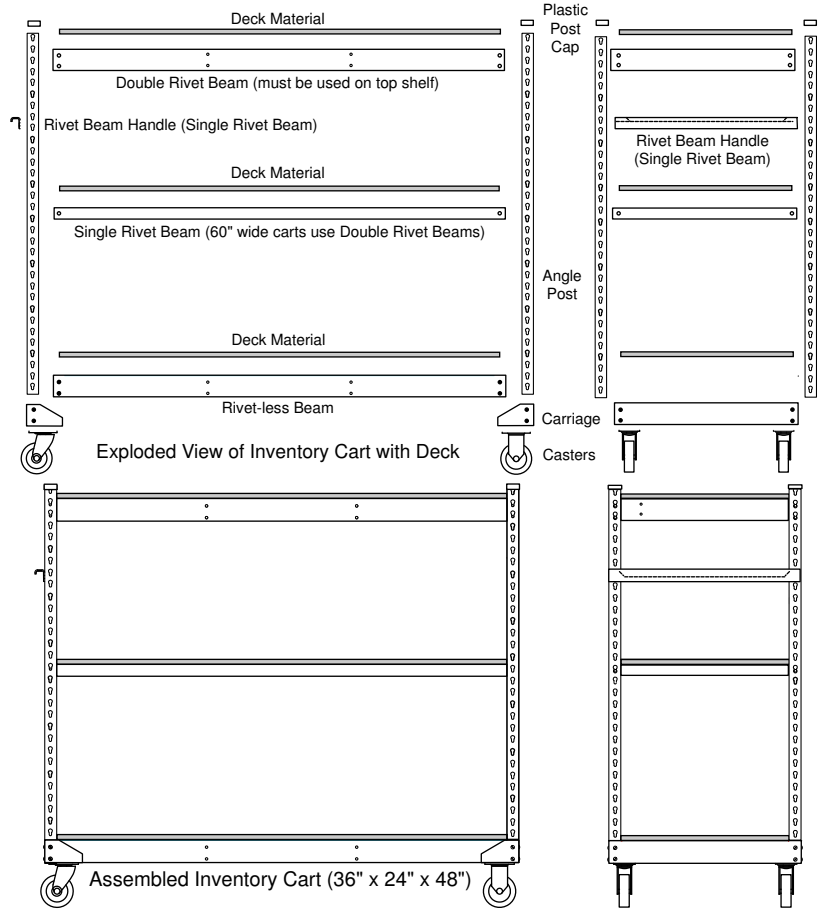

## TOOLS NEEDED

Flat Head Screwdriver (large)



7/16" Open Faced Wrench



Rubber Mallet



## STEP 1

Align Caster Plate with holes in Carriage and drop bolts (5/16"-18 x 5/8") through four holes on Carriage base and then through Caster Plate. Place 5/16" flat washer over bolt ends and then thread and tighten nuts (each Carriage gets two sets of wheels, one Carriage gets two swiveled wheels, the other Carriage gets two fixed wheels).

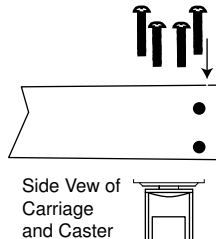
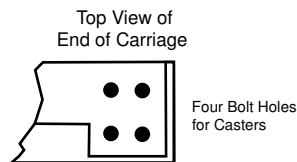
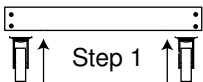

## STEP 2

Insert each Rivet Angle Post into the inside corners of each Carriage so bottom of Rivet Angle Post rests on carriage. Insert two bolts (1/4"-20 x 5/8") through two holes in the 24" long side of each Carriage corner and then the Angle Post. Slide External Tooth Lock Washer over each bolt then thread and tighten nuts.

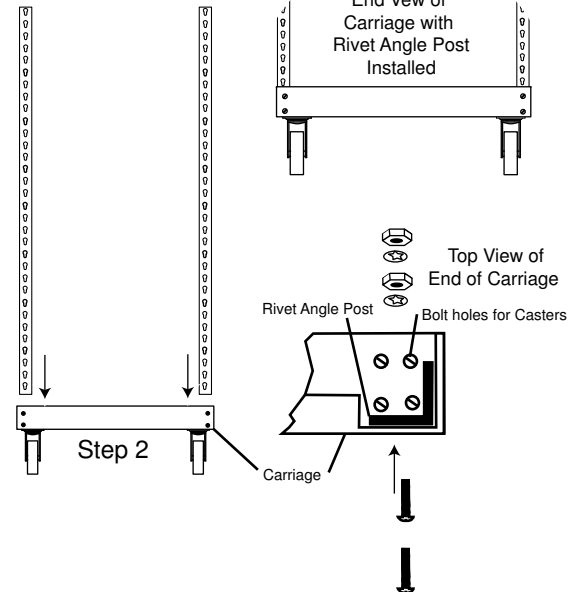

# Inventory Cart Assembly Instructions Part No. 8767

### STEP 3

Insert two bolts (1/4"-20 x 5/8") through the two holes on each 5" long side of the Carriages and then through the Rivet Angle Post. Insert the two bolts on the Rivet-less Beam onto the two holes on the 5" side of the each carriage. Slide External Tooth Lock Washers over bolts and then thread and tighten nuts. Bolt other end of Rivet-less Beam to remaining carriage. Lay deck material on top of Rivet-less Beam and carriage assembly to complete the bottom shelf.

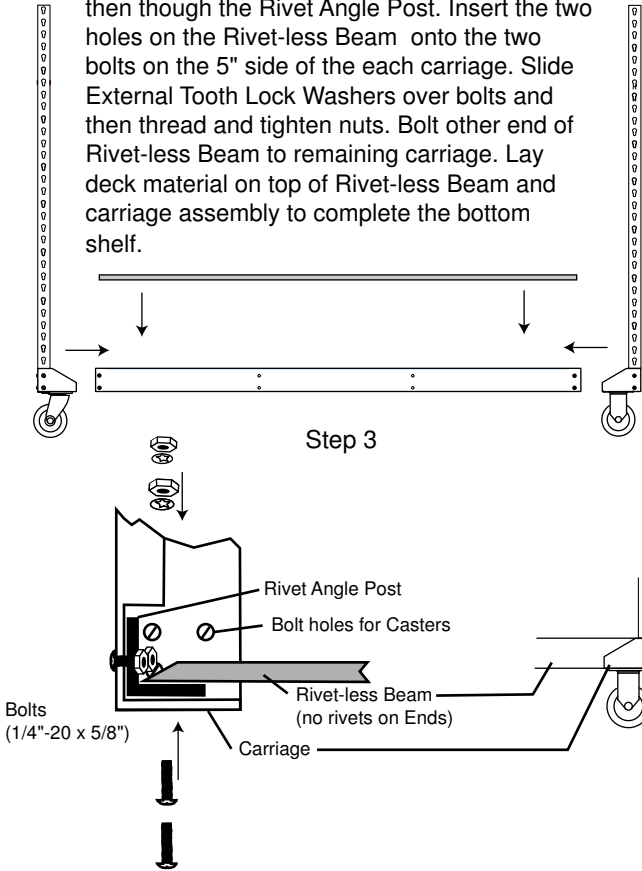

### STEP 4

Choose the location of the next shelf and insert the rivet(s) on each end of Rivet Beam in the appropriate hole on Rivet Angle Posts. Tap end of Rivet Beam with rubber mallet so the rivet is fully seated in bottom of the hole. Each shelf level uses four Single Rivet Beams (60" wide Carts use Double Rivet Beams). Place deck material on Rivet Beam. Repeat Step 4 for each shelf level (if supplied) except for the top shelf.

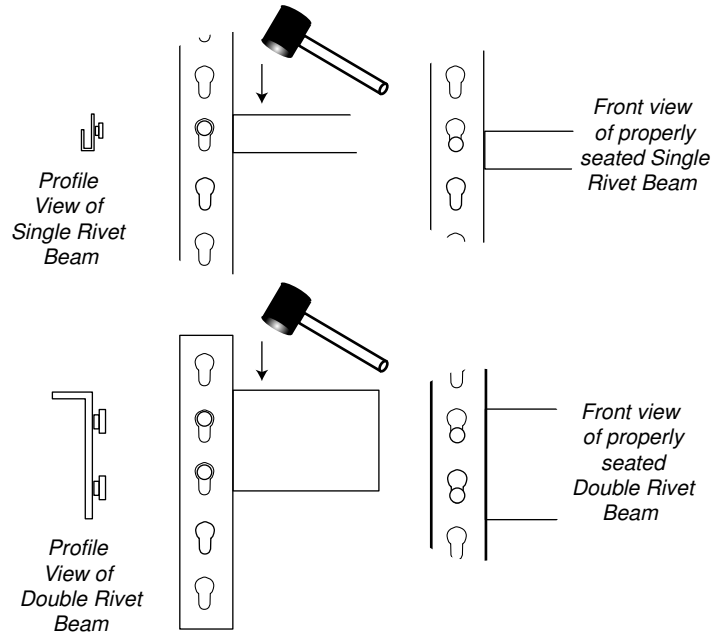

### STEP 5

The top shelf level requires four Double Rivet Beams. Insert the two rivets on the Double Rivet Beam ends one hole down from the top hole of the Rivet Angle Post. Tap ends of Double Rivet Beam so rivets are fully seated at bottom of the hole. Repeat step for each Double Rivet Beam. Place deck material on Double Rivet Beam, then place Plastic Post Caps on top of Rivet Angle Posts. Choose height of Push / Pull Handle (remaining 24" Single Rivet Beam), tap ends of Single Rivet Beam into Rivet Angle Post holes on the side with swivel wheels.

