

Pflow Series D Hydraulic Vertical Lift DIMENSIONS & DATA

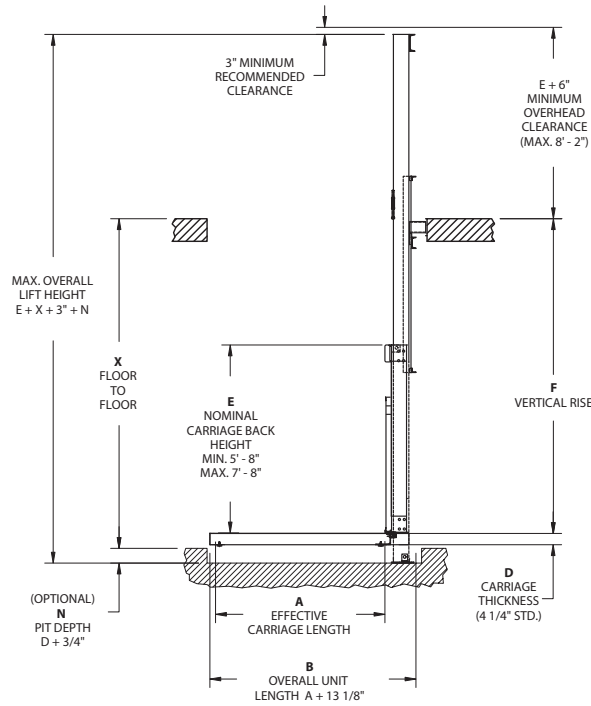
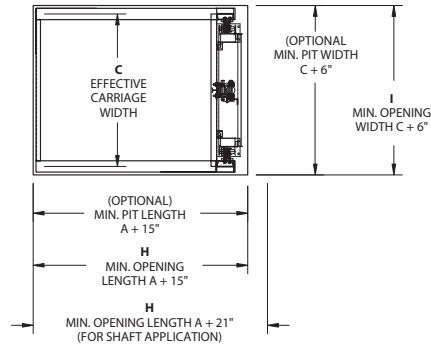

- | | |
|--|---|
| A Effective Carriage Length: | Load Size: W L H |
| B Overall Unit Length: | Load Weight: |
| C Effective Carriage Width: | Loads Per Hour: |
| D Carriage Thickness: | Location: <input type="checkbox"/> Interior |
| E Load Height: | <input type="checkbox"/> Exterior |
| F Vertical Rise: | |
| H Upper Level Opening (Length): | |
| I Upper Level Opening (Width): | |

Note: The dimensions shown are illustrative. Request a job-specific drawing before making any building modifications.

Series D Hydraulic Lift Loading/Unloading Patterns:

- C-Pattern
- Z-Pattern
- 90°-Pattern

Note: All Patterns Are Reversible.

