



VersaKing System Instructions

Porta-King Job No. : 1234 _____

Job Name : _____

Ship to Location : _____

Distributor : _____

VERSA KING SYSTEM

SYSTEM SIZE: 3"	SHIP DATE: 10-08-04	JOB# : 1234
HGT.: 96"	EXTRUSION COLOR: Aluminum	
DISTR: INT. COLOR:Hardboard-Beige		
JOB NAME: EXT. COLOR:Hardboard-Beige		
LOCATION: GLAZING:3/16" Clear Temp		
PROC. BY: CMP DATE: 09-21-04	2nd CK: CMP	FINAL CK: JA DATE: 09-22-04

Panel Layout Drawing

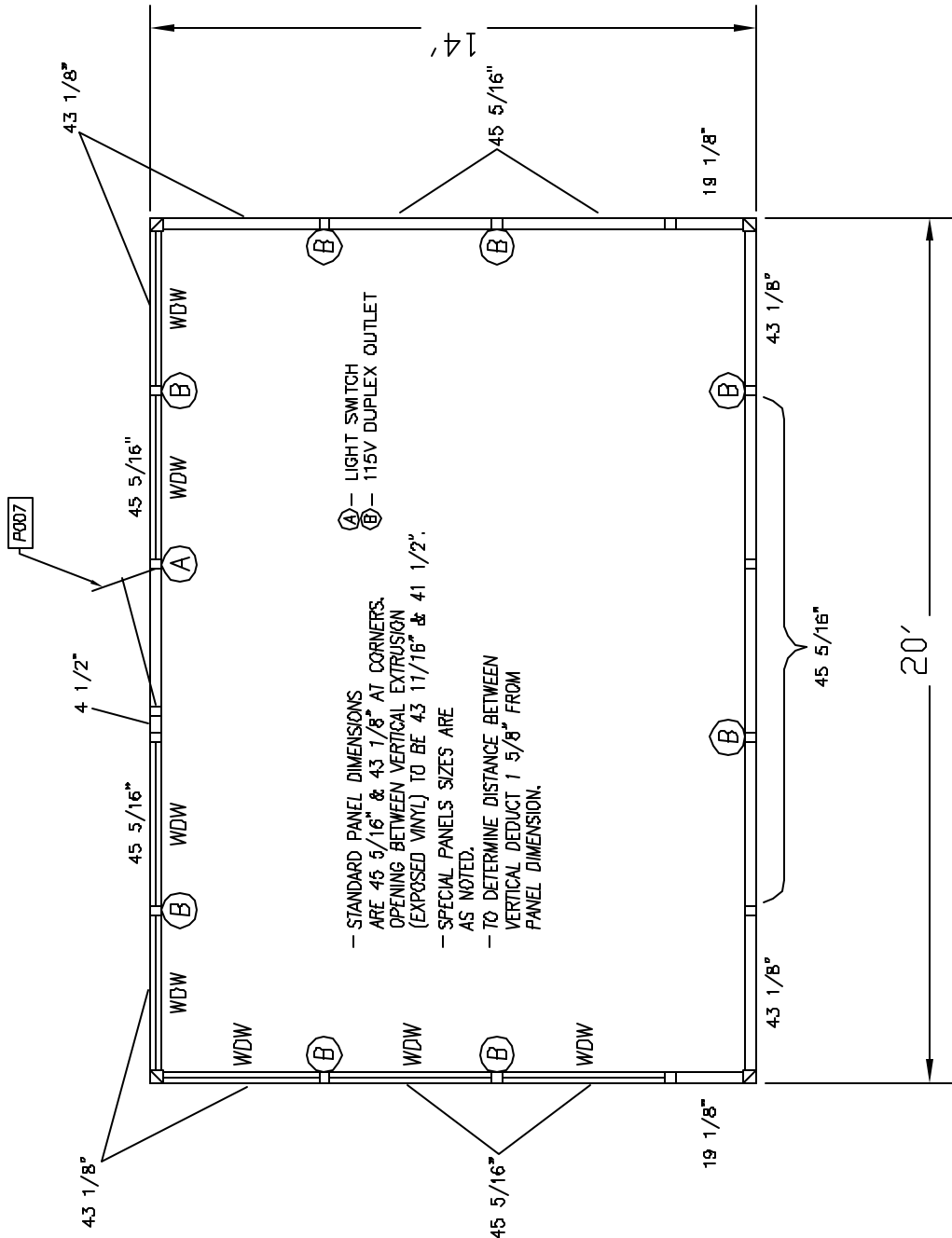

VERSA KING SYSTEM	SYSTEM SIZE: 3"	SHIP DATE: 10-08-04	JOB# : 1234
	HGT.: 96"		EXTRUSION COLOR: Aluminum
DISTR:	INT. COLOR: Hardboard-Beige		
JOB NAME:	EXT. COLOR: Hardboard-Beige		
LOCATION:	GLAZING: 3/16" Clear Temp		
Roof & Ceiling Drawing			

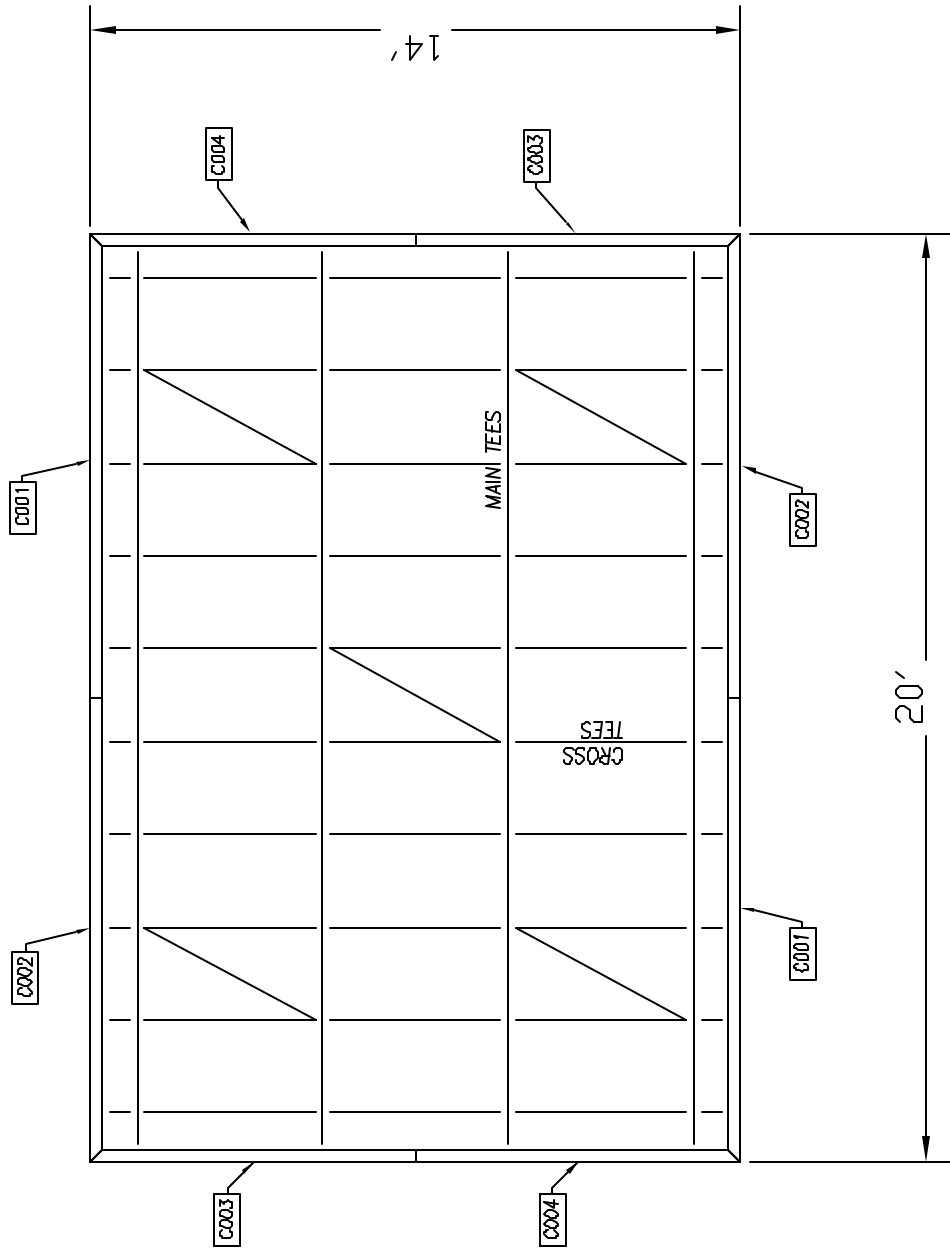

Deck
Dir. ↗

Roof Deck Table		
MARK	QTY	ROOF DECK PART NUMBER
R001	7	RD02-3600-168-00

VERSA KING SYSTEM

SYSTEM SIZE: 3"

SHIP DATE: 10-08-04

JOB# : 1234

HGT.: 96"

EXTRUSION COLOR: Aluminum

DISTR:

INT. COLOR: Hardboard-Beige

JOB NAME:

EXT. COLOR: Hardboard-Beige

LOCATION:



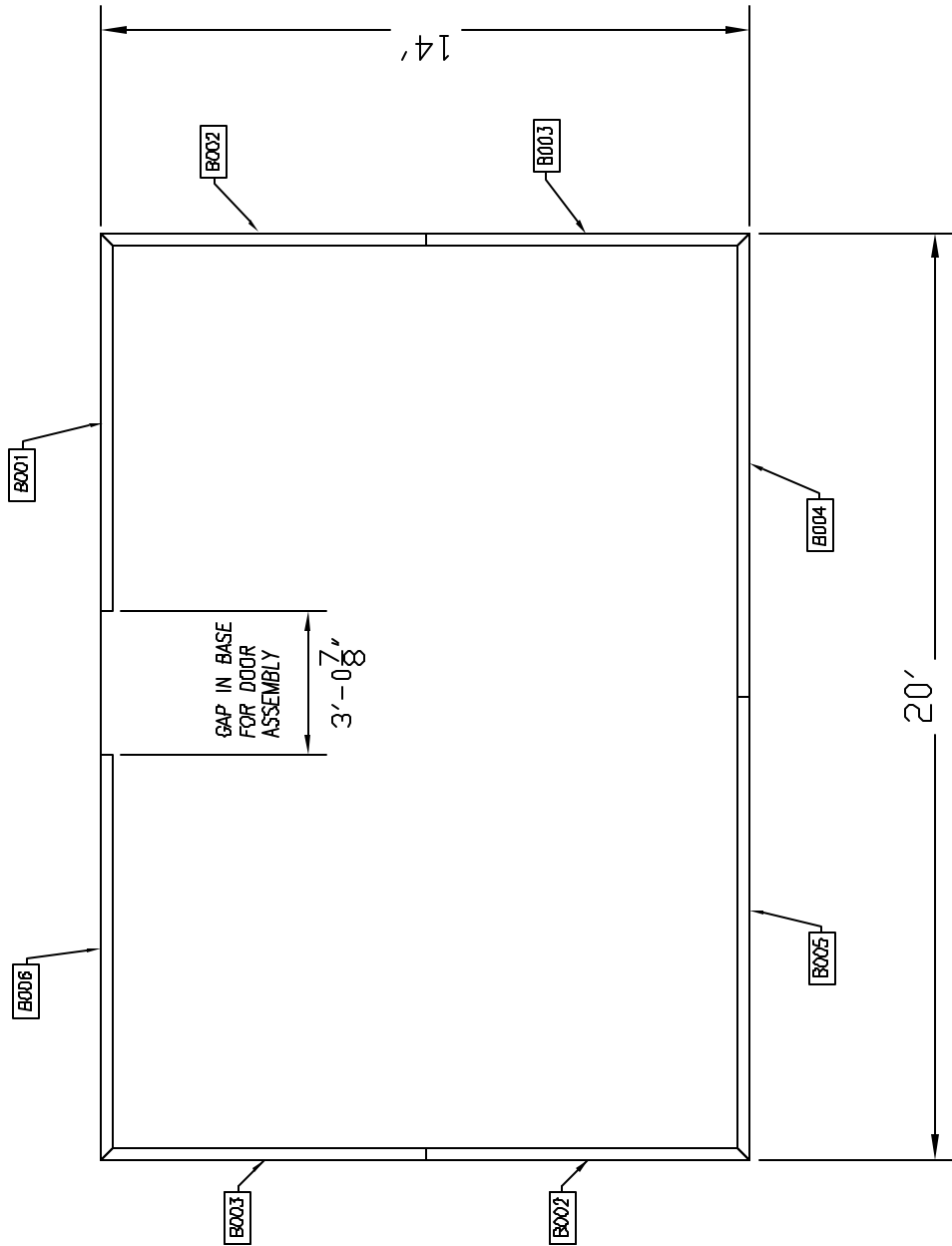

GLAZING: 3/16" Clear Temp









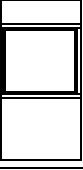
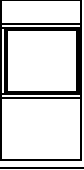
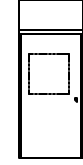

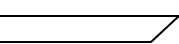
Base Plate Drawing

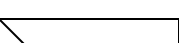

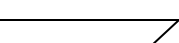
Porta-King Packing List

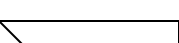

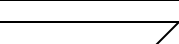

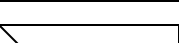
Job No. 1234
Customer
Distributor

Item No.	Qty.		3" VK Solid Pnl	Item No.	Qty.		3" VK Solid Pnl
P001	1		Panel Width : 4 1/2"	P002	2		Panel Width : 19 1/8"
			Panel Height : 95 7/8"				Panel Height : 95 7/8"
Item No.	Qty.		3" VK Solid Pnl	Item No.	Qty.		3" VK Solid Pnl
P003	3		Panel Width : 43 1/8"	P004	5		Panel Width : 45 5/16"
			Panel Height : 95 7/8"				Panel Height : 95 7/8"
Item No.	Qty.		3" VK Fxd Glass Pnl	Item No.	Qty.		3" VK Fxd Glass Pnl
P005	4		Panel Width : 45 5/16"	P006	3		Panel Width : 43 1/8"
			Panel Height : 95 7/8"				Panel Height : 95 7/8"
Item No.	Qty.		3" VK Door Pnl				
P007	1		Panel Width : 38 1/8"				
			Panel Height : 95 7/8"				
			SCD w/VL				

Item No.	Qty.		Cut Style	Part Number	Part Length	Angle Cut	Description
B001	1			RI12246-45-098-01	98 1/16"	45	3" Base PLate
B002	2			LI12246-45-084-01	84 1/16"	45	3" Base PLate
B003	2			RI12246-45-084-01	84 1/16"	45	3" Base PLate
B004	1			LI12246-45-120-01	120 1/16"	45	3" Base PLate
B005	1			RI12246-45-120-01	120 1/16"	45	3" Base PLate
B006	1			LI12246-45-105-04	105 1/4"	45	3" Base PLate

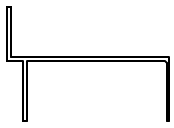
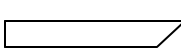
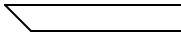
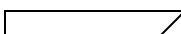
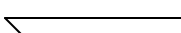
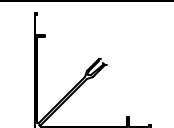
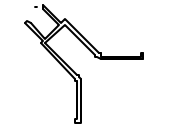
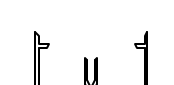

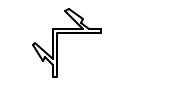
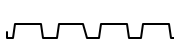

Porta-King Packing List

Job No. 1234
Customer
Distributor

Item No.	Qty.		Cut Style	Part Number	Part Length	Angle Cut	Description
C001	2			RI12214-45-120-08	120 1/2"	45	3" Roof Cap
C002	2			LI12214-45-120-08	120 1/2"	45	3" Roof Cap
C003	2			RI12214-45-084-08	84 1/2"	45	3" Roof Cap
C004	2			LI12214-45-084-08	84 1/2"	45	3" Roof Cap
V001	4			Part Number SC12234-096-00	Part Length 96"		Description 3" PK-VK Corner
V002	4			Part Number SC12235-096-00	Part Length 96"		Description 3" PK-VK Corner Cover
V003	15			Part Number SC12706-096-00	Part Length 96"		Description 3" Versa King Ext Connector
V004	15			Part Number SC10981-096-00	Part Length 96"		Description 3" Versa Connector Cover
V005	15			Part Number SC12705-096-00	Part Length 96"		Description 3" Versa King Int Connector
V006	4			Part Number SCPVC90-096-00	Part Length 96"		Description PVC 90 Cover
RD01	7			Part Number RD02	Part Length 168"		Description Roof Deck 1 1/2" x 18 Ga. x 36" x 168"
GO01	6			Part Number WALLMAN144	Part Length N/A		Description Wall Moulding Angle 1" x 1" x 12"

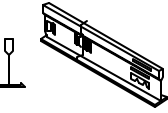

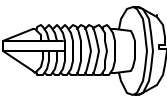

Porta-King Packing List

Job No. 1234
Customer
Distributor

Item No.	Qty.		Part Number	Part Length	Description
G002	20		HT	N/A	SCREW-ON TYPE HANGER TAB w/24" TIE WIRE
G003	8		MNRNR144	N/A	Main Runner 1 1/2" x 12'
G004	40		CROSST48	N/A	Cross T x 48" Long
G005	32		ACT2X4	N/A	Acoustical Tile Board 2' x 4'
H001	125		TEKSM12-12	N/A	#12x 3/4" Slotted Hex Head Screw
H002	300		TEKSM58-8	N/A	SM Screw 5/8" #8
H003	1		NUTSETTER	N/A	5/16" NUT SETTER
E001	8		EC115VD20	N/A	115V Duplex Outlet-IVORY
E002	8		ECDPCVR	N/A	Duplex Cover Plate-IVORY
E003	9		EC15BX	N/A	2"x4"x 1 7/8"d J-Box
E004	1		ECSW15	N/A	Light Switch-IVORY
E005	1		ECSWCVR	N/A	Switch Cover PLate-IVORY

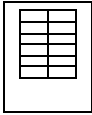
Porta-King Packing List

Job No. 1234
Customer
Distributor

Item No.	Qty.		Part Number	Part Length	Description
E006	5		LT160WTROFF	N/A	160WATT RECESSED TROFFER LIGHT
E007	1		LC-Q06/12	N/A	LOAD CENTER-Q0-6/12 WITH GROUND BAR KIT
E008	3		115V-15T	N/A	115V-15A TANDEM BREAKER
M001	1		STD-LOCK	N/A	STD CYLINDRICAL LOCKSET
M002	12		DKBRACE	N/A	14" DECK BRACE

BEFORE BEGINNING INSTALLATION, PLEASE READ THROUGH ALL INSTRUCTIONS.

Uncrate shipment and check against packing list to insure all materials are included before beginning installation. If any discrepancies are noted, please notify the factory immediately at (800) 456-5464.

Note: All building dimensions are outside (O.D.), unless shown or noted otherwise on drawing.

RECOMMENDED TOOLS FOR INSTALLATION:

- | | | |
|--------------------|--------------------------------|-------------------|
| Tape measure | Chalk line | Carpenter's level |
| Hammer | Hacksaw | Broom |
| Combination square | Pliers | Utility knife |
| Rubber mallet | Screwdriver | Extension cord |
| Circular saw | Drill bits (metal and masonry) | Power drill |
| Step ladder | | |

Fasteners and supplies are required for tying into existing floor and walls.

Note: Porta-King will supply one nutrunner attachment for installation of #12-3/4" slotted hex head screw.

1. CONSTRUCTING A CHALK LINE LAYOUT:

Strike a chalk line (#1) on the floor to establish location of the first wall. This line will represent the outside edge of the base plate. Using the 3,4,5 triangle method, construct the first corner of your building. Measure 4' from point A on line #1, and mark this point B. Strike a 5' arc from point B and a 3' arc from point A, the intersection of the two arcs is point C. Strike chalk line #2 through point A and C to form a 90 degree corner. Continue with this procedure to establish the remaining chalk lines. Once layout is complete, take diagonal measurements from corner to corner. Diagonal measurement should be within 1/8" of each other to ensure the building is in square.

DETAIL INSTRUCTION No. 1

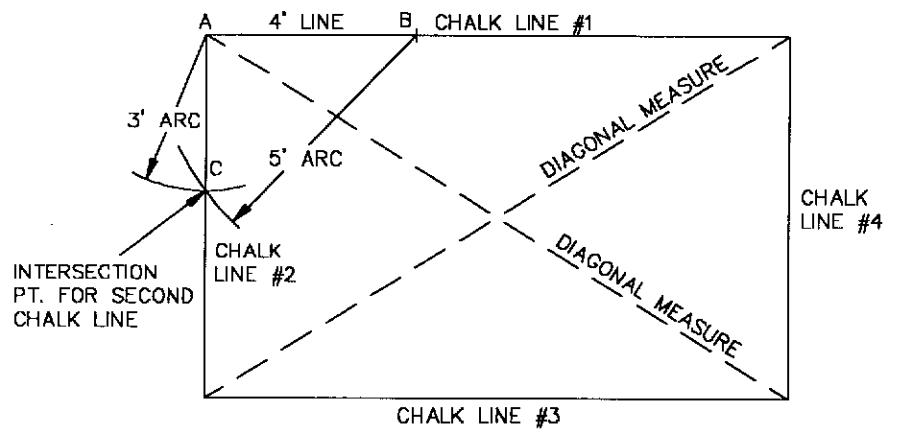

2. BASE PLATE INSTALLATION:

The base plate will be mitered and sized to fit the required layout. Attach the base plate to the foundation using appropriate fasteners, install the fasteners starting from one corner and proceeding on 24" centers.

Appropriate fasteners for attachment of the base plate to the foundation to be furnished by others, depending on site conditions.

Note: Be sure that the base plate is installed level and in square.

DETAIL INSTRUCTION No. 2

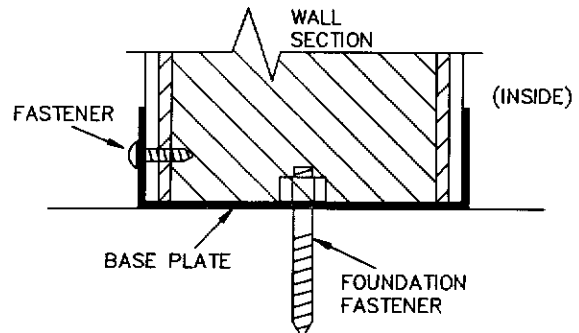

3. CORNER POST - PANEL INSTALLATION:

(If the building is a Two or Three Wall type which is attached to existing walls, refer to Instruction #9.)

Start with one corner post. Insert corner post into base plate at any corner (support corner until panels are installed on each side). Insert panel into base plate and corner post, sliding panel firmly into place, proceed with panel on opposite side of corner post. Screw corner cover to corner post with #12 x 3/4" slotted hex head screws to secure panels.

Notes: Check layout for appropriate colors for interior and exterior of building.

Check layout for any critical dimensions. Refer to Installation Drawings for proper location of sized components.

Visually inspect to ensure panels fit properly at all connections. Panel should fit flush with panel stop of corner or connector. As each wall is installed, be sure the length of wall is the same dimension at the top and bottom, to keep wall square.

Buildings with overheight wall panels will have a splice. Shim splice as required to keep level.

Helpful hint: Start the #12 x 3/4" slotted hex-head screws into covers before putting the covers into place.

DETAIL INSTRUCTION No. 3

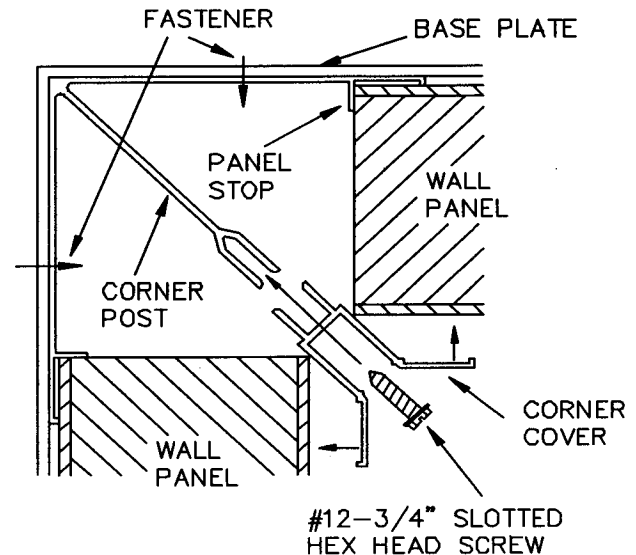

DETAIL INSTRUCTION No. 4

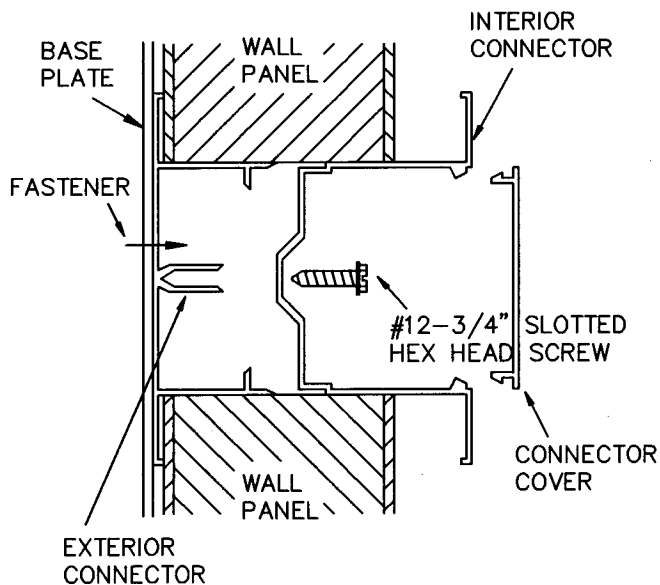

4. CONNECTOR - PANEL INSTALLATION:

Insert exterior connector into base plate and slide firmly against panel. Insert the next panel on the other side of the exterior connector. Attach interior connector to exterior connector with #12 x 3/4" slotted hex head screws to secure panel connection. Plumb every panel connection. Once panel connection is secured, install #8 x 5/8" self drilling screw through 1 1/4" lip of base plate and into connector.

Install connector cover by snapping into interior connector. If electric is required in connector, wait to install connector cover until electric is installed.

Note: Install #8 x 5/8" self drilling screw after each panel connection to secure vertical extrusion to baseplate.

5. ELECTRICAL BOX INSTALLATION:

The light switches and electrical outlets are shipped from the factory knocked down and are to be installed on site. The electrical junction boxes are to be installed on site, using the #8 x 5/8" self drilling screws supplied. Screw through the back of the junction box and into the connector. After junction box is attached, measure and cut the connector cover to fit above and below junction box.

Note: You may also want to cut the connector cover just above or even with the ceiling line to facilitate later access without removal of the ceiling.

DETAIL INSTRUCTION No. 5

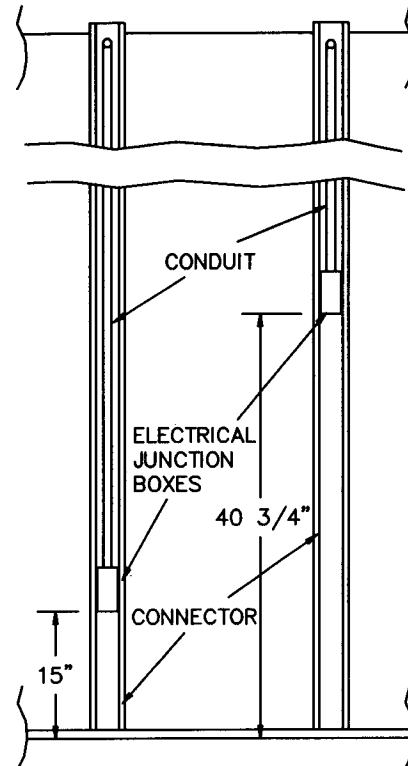

6. CEILING CAP INSTALLATION:

The ceiling cap will be mitered and sized to fit the required layout. It is important to install the ceiling cap in conjunction with the wall panels to ensure the dimensional stability of the building. Secure adjacent ceiling cap pieces by using #8 x 5/8" self drilling screw through the ceiling cap and into the gusset plate. Secure ceiling cap to the vertical extrusion (corner post and connector) by fastening through the ceiling cap legs and into the vertical extrusions with a #8 x 5/8" self drilling screw. Do this at every panel connection, on both the interior and exterior around entire perimeter of building.

DETAIL INSTRUCTION No. 6

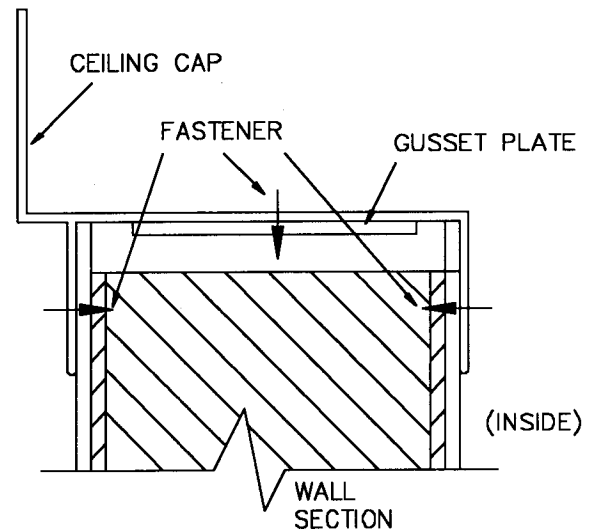

7. DOOR INSTALLATION:

Door is shipped as a complete unit. Install door unit in the same manner as wall panels. Place header panel on top of door unit. Check for door alignment and swing.

Note: After installation of door frame assembly, fasten 2" flat head tek screws above and below top hinge into adjacent vertical connector.

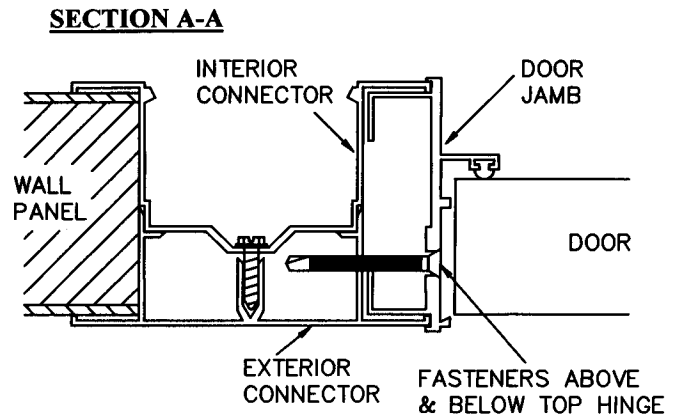

DETAIL INSTRUCTION No. 7

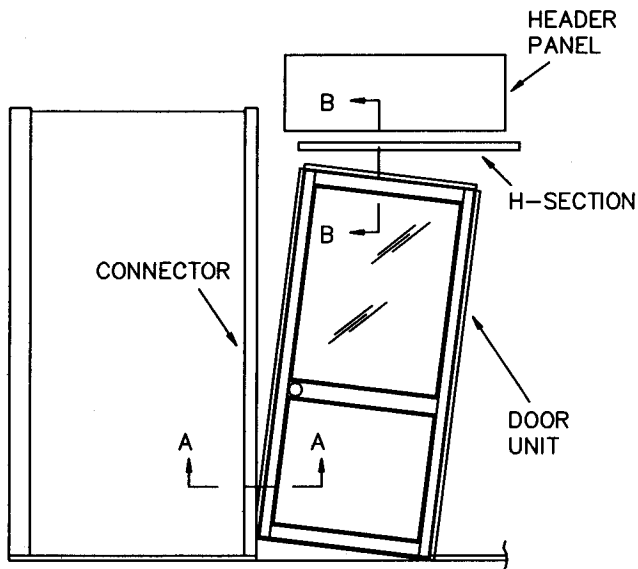

SECTION B-B

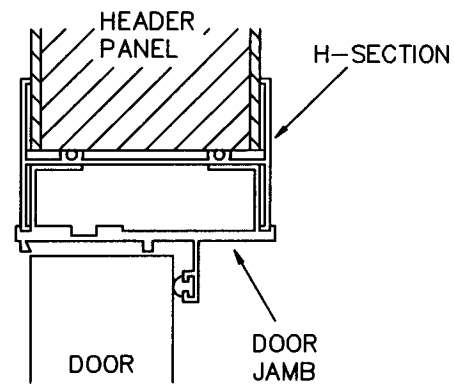

8. WINDOW INSTALLATION:

Window Panel units are shipped in three pieces. Install window panel unit in the same manner as wall panels. Insert lower panel into base plate. Place glazed window unit on top of lower panel with window sill to the interior side of building. Install upper panel on top of glazed window unit.

Note: Window and vertical extrusion must interlock to form proper connection. Window panels are sized to meet required dimensions, refer to layout for location of sized window panels.

DETAIL INSTRUCTION No. 8

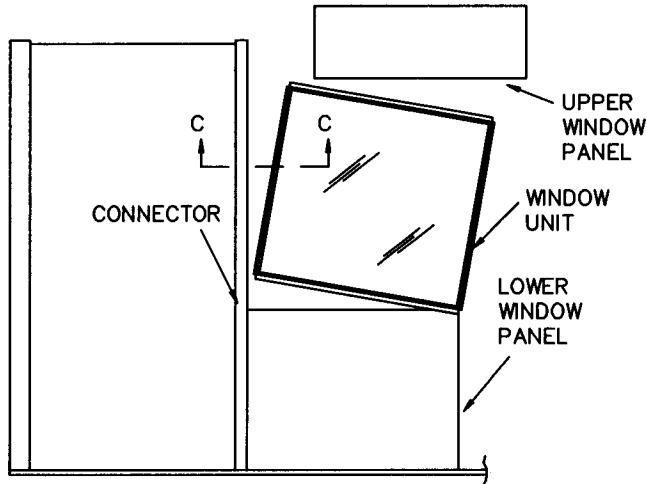

SECTION C-C

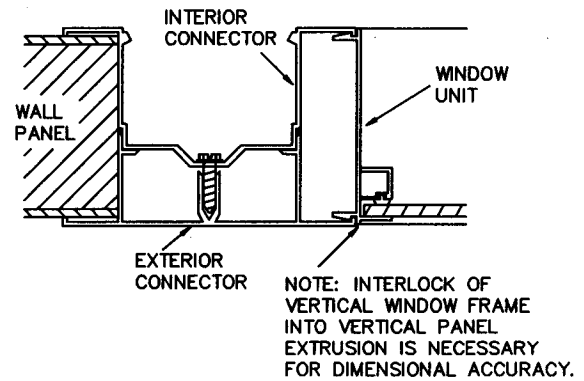

9. TWO and THREE WALL BUILDINGS:

Attach wall start (channel) to the existing wall with appropriate fasteners. Insert exterior connector over wall start and place panel into other side of connector. Attach interior connector to secure to wall start. Refer to Instruction #4. Connector-Panel Installation and continue installation of wall panels. Wall panels will terminate at existing wall, align the second wall start and fasten to the existing wall. Attach connector to final panel and wall start. Install roof support angle on existing walls with appropriate fasteners. Roof support angle will support roof decking at existing walls.

Note: Appropriate fasteners for attachment of the wall starts and roof support angle to the existing walls are to be furnished by others, depending on site conditions.

9a. INTERIOR PARTITION:

For buildings with interior partitions, install interior partition in the same manner as Two and Three Wall Buildings.

Install partition cap on interior partition wall and fasten to vertical extrusions with a #8 x 5/8" self drilling screw.

DETAIL INSTRUCTION No. 9

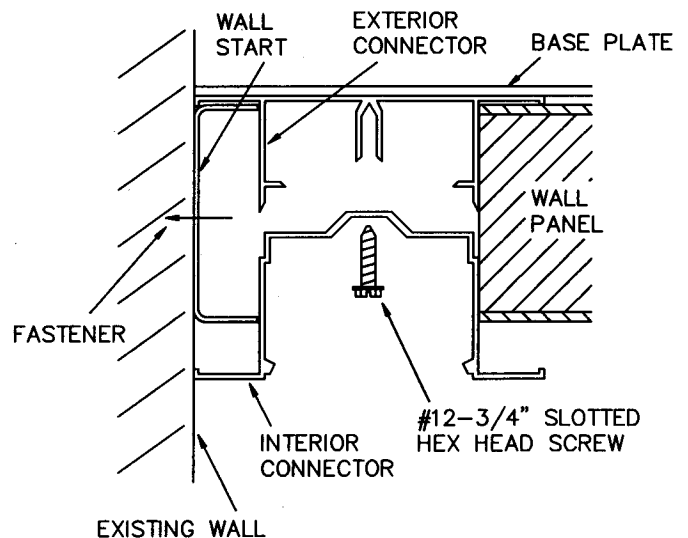

10. ROOF DECKING INSTALLATION:

(If the building is for Storage loading or a Two-story with wide flange beams, proceed to Instruction #11 Storage Loading Installation)

Install roof deck on top of ceiling cap, nesting roof deck panels as shown in the detail. Fasten the roof deck to the ceiling cap with #8 x 5/8" self drilling screws, 18" on center around the entire perimeter of the building.

Refer to Instruction #14. Acoustical Ceiling, for hanger tab placement information.

Note: Buildings wider than 16' require Wide Flange Support Beams to shorten the decking spans. Install Support Beams on ceiling cap, at vertical extrusions, and fasten with #8 x 5/8" screws. Install decking on lower flange of beam and fasten with #12 x 1 1/4" TEK screws, 18" on center

DETAIL INSTRUCTION No. 10

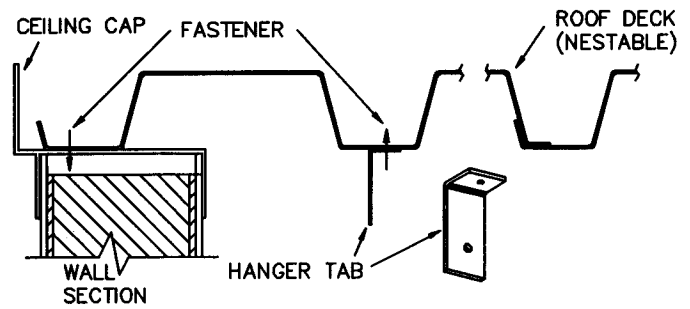

10a. Deck braces are only supplied for buildings with 1 1/2" decking that is longer than 12'. Install deck braces before installing the ceiling grid system. Braces are made to be installed at the joints and the valley's on either side of the joint (approximately 5' apart), as shown on the drawing. Use the #8 x 5/8" self drilling screws to fasten the braces to the underside of the decking.

DETAIL INSTRUCTION No. 10a

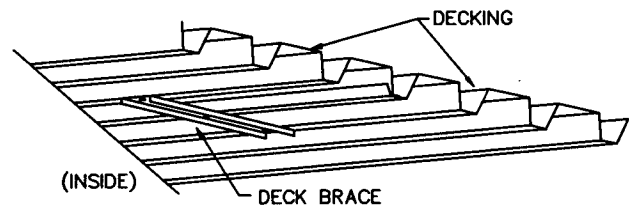

DETAIL INSTRUCTION No. 11

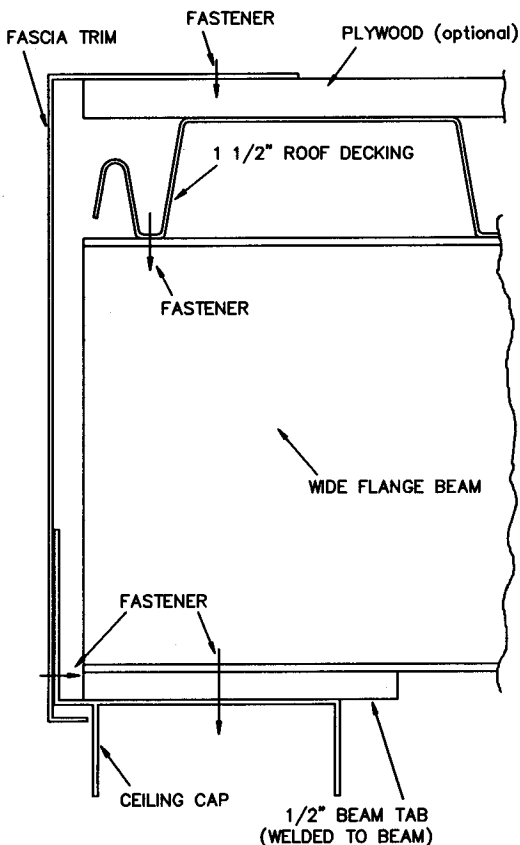

11. STORAGE LOADING INSTALLATION:

After the walls are up and all the ceiling cap is in place, install the wide flange beams. Refer to installation drawings for beam location and direction, beams should run parallel with the short direction of the building and should be installed 48" on center at the vertical extrusions. The beams have a steel plate welded on each end, screw through the plate and into the ceiling cap with #10 x 1 1/2" screws. After all beams are installed, proceed to Instruction #10 Roof Decking Installation, and install the roof decking on top of the beams and fasten with #12 x 1 1/4" tek screws. If plywood is to be installed on roof decking, fasten appropriate plywood with #6 x 1 1/4" bugle head screws. Fascia trim will be provided in 8' pieces and is sized to fit under outside of ceiling cap and over the plywood or decking. Fasten fascia trim to ceiling cap and plywood or decking with #8 x 5/8" screws.

Note: For two-stories, after storage loading roof is installed on first floor, install second story in the same manner as the first floor.

12. PVC COVER STRIP INSTALLATION:

The 8' long PVC cover strips snap into place to hide the #12 x 3/4" hex-head screws. The PVC 90 cover is installed in each corner cover.

DETAIL INSTRUCTION No. 12

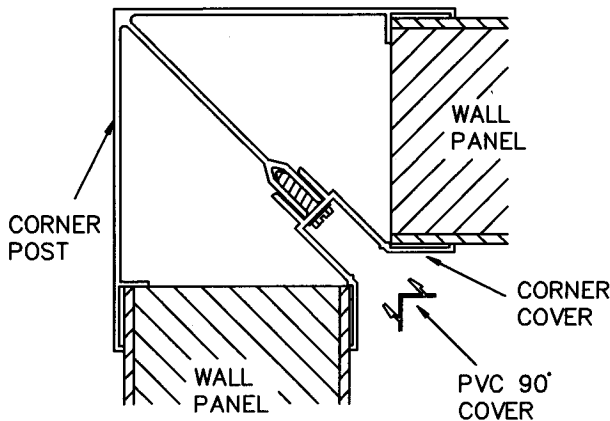

Installing Wall Molding Angle:

Determine exact height at which the suspended ceiling is to be placed. If recessed lights are to be used, a minimum of 6" clearance between the roof deck and the finished ceiling is required. In most applications, the ceiling is installed approximately 7'-6" from the finished floor.

After the exact position of the suspended ceiling has been located, use a level to draw a level line completely around the room to indicate where the wall angle is to be applied. Fasten the wall angles securely to the wall every 12" using #8 x 5/8" self-drilling screws.

Position the wall angle in such a way that the bottom flange is on the level line that you have drawn on the wall.

Overlap the wall angle on inside corners, and miter the wall angle on outside corners.

13. ACOUSTICAL CEILING INSTALLATION:

Get the exact measurements of the room where the suspended ceiling is to be applied, using special care in measuring any odd shape.

Sketch the layout for the planned ceiling on graph paper and draw the main T's 4' apart. Position the main T's in such a way that border patterns at room edges are equal on both sides and as large as possible. It is usually wise to sketch several layouts to see which looks best before beginning the actual installation (and you will also want to consider the best location for your light fixtures that will lie in the grid system).

It is important that the cross T's be spaced so the border panels at the ends of the room are equal, and as large as possible, using 2' x 4' pattern, and space the cross T's 2' apart.

If recessed built-in lighting is to be installed, decide where these panels of light will be located and clearly identify them on the drawing.

Locating and Hanging Tie Wires for Main T's:

If recessed lights are to be used in the ceiling, the electric wiring should be installed before the tie wires are put into place.

Refer to the sketch of the room that you previously drew for the location of all Main T's.

Locate the position of each main T by stretching a tight line from the top edge of the wall angle on each side of the room at each position where the main T's are to be placed.

Now cut the tie wires to the proper length. Tie wires should be 12" longer than the distance between the roof deck and the new guide line string which you have stretched to indicate the position of each main T.

Locate the first tie wire for each main T directly above the point where the first cross T meets with main T.

Be sure the tie wires are securely fastened to hanger tabs which have previously been installed in conjunction with installation of the roof deck.

Pull on each wire to remove any kinks, and then make a 90 bend where the tie wire crosses the level line.

Installing Main T's:

Main T's are 12' long and have cross T slots punched every 12" beginning 6" from each end.

Determine the distance from the wall to the first cross T. Now measure this distance along the top flange of the main T, and locate the slot just beyond this point.

From this slot, measure back the same distance, less 1/8", and saw the main T at that point. The 1/8" subtraction is for the wall angle thickness.

When main T's are installed in rooms less than 12' across, cut the main t to the exact measurement of the room, allowing 1/8" for the thickness of the wall angle.

If room is wider than 12', main T can be spliced. Be sure to align the splice in such a way that suspension wires are correctly positioned. Carelessness in splicing can throw off all Main T's.

Install the main T's using care to keep all T's level with the wall angle previously mounted. A long level can be used for this purpose.

Installing Cross T's and Border Cross T's:

Cross T's are installed by inserting the ends of the Cross T's into the slots in the main T's every 2' apart.

Be sure the lock tab on the cross T is on the outside of the slot.

Border cross T's are installed between the wall molding and the last main T. Measure from the last T to the wall molding, allowing 1/8" for the thickness of the wall angle. Cut cross T's and install, inserting the connector in the main T and resting the cut edge on the wall angle.

Installing Ceiling Panels:

Ceiling panels can be dropped into position by tilting them slightly, lifting above the framework and letting them fall into place. Border tiles must be cut to size.

They could be cut with a sharp knife on any level surface. Always cut with the finished side up. A scrap piece of T can be used as a straight edge. Keep knife sharp.

Note: Acoustical grid system is not designed to support weight. Heavy construction should be supported from special framing. It should never be suspended from the acoustical grid system.

14. LIGHT FIXTURE INSTALLATION:

Light fixtures are recessed type with lens and will lay in ceiling grid. Light fixtures should be positioned at convenient locations for the particular office layout.

15. LOAD CENTER INSTALLATION:

Load center will be shipped separate, and will be provided with breakers to accommodate the other electrical equipment ordered.

Note: Wiring and conduit runs from load center to electrical items to be furnished and installed by others.

INSTALLATION INSTRUCTIONS FOR OPTIONAL ITEMS:

BACK-TO-BACK WALL START:

Back-to-back wall starts to be installed at locations of two adjacent vertical extrusions; for example, corner-wireway as detail shows, wireway-wireway, or as noted on installation drawing as required.

BACK-TO-BACK WALL START

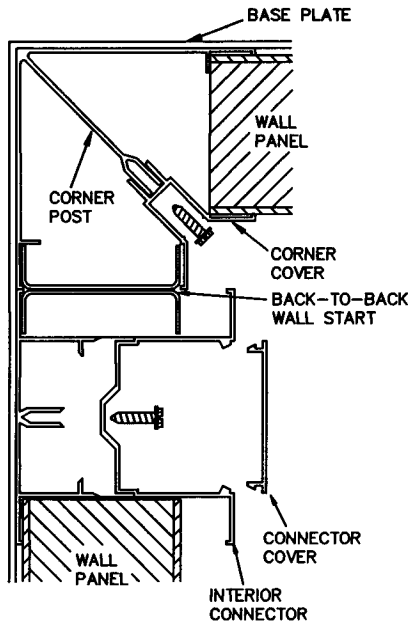

to support the ceiling load and prevent sag of header and top frame of double door.

Remove screws from deck into ceiling cap, if they have been installed, above double door. Install double door support between roof decking and ceiling cap. Before fastening double door support, be sure frame and doors are aligned properly and verify the top frame is level. Once door is aligned, drill 3/16" hole thru double door support only, do not drill thru vertical extrusion. Fasten with #8 x 5/8" screws, (2) each vertical extrusion. Fasten roof deck thru double door support and into ceiling cap.

DOUBLE DOOR SUPPORT

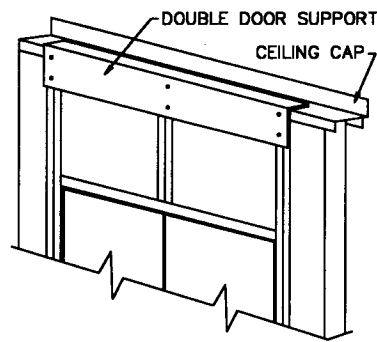

PIVOTLOCK CEILING:

Pivotlock ceiling panels are numbered and installed in sequence. Place each section in top pivot point and snap in place. Fasten thru ceiling panel and into ceiling cap with #10 x 4" screws, 24" o.c. around entire perimeter of building. Install fascia trim with #8 x 5/8" screws to pivotlock ceiling panels.

PIVOTLOCK CEILING

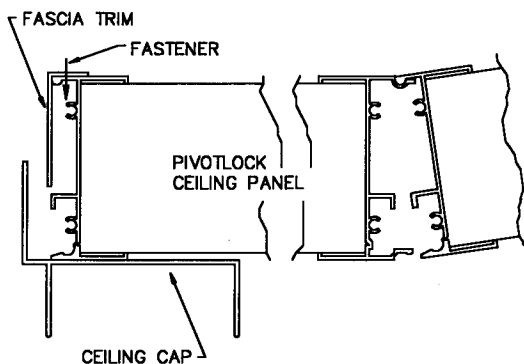

DOUBLE DOOR SUPPORT:

Double door support to be installed over double door

FLOOR STRUCTURE:

Floor structure to be factory assembled and shipped in 4' wide sections. Splicing trim is attached to each section and pre-drilled for connection to adjacent section.

After floor structure is complete, refer to Instruction #2, Base Plate Installation.

FLOOR STRUCTURE

