

P3 Model

Presto Pallet Positioner

Installation, Operation and Service Manual

Model Number _____

Serial # _____

Date placed in service _____

**IMPORTANT: READ CAREFULLY
BEFORE INSTALLING OR OPERATING LIFT**

Part orders are subject to a \$50 net minimum charge.

November 2010



The Presto Five Year Warranty

Presto Lifts, Inc. warrants all of its products against defects in the welded structural frame and, if applicable, scissor legs from faulty material and workmanship for a period of five years from the date of invoice. To read more about the warranty on this equipment, please turn to the back inside cover of this owner's manual.

This manual was current at the time of printing. To obtain the latest, most updated version, please contact the Customer Service Department or go to our website: www.PrestoLifts.com -- you will find a complete list of current owner's manuals to print.

CONTENTS

INTRODUCTION	Page 3
SAFETY	3
Installation Notes	4
Operation Notes – Manual Use	4
Operation Notes – Use with Fork Lift	5
SPECIFICATIONS	5
INSTALLATION INSTRUCTIONS	5
Unpacking the Unit	5
Set-up and Instructions	6
Set-up Procedures	7
Quick Set-up.....	8
OPERATING INSTRUCTIONS	8
Loading Manually	8
Removing Loads Manually	8
Operating Safety – Manual Use	8
Loading with a Fork Lift	9
Unloading with a Fork Lift.....	9
Moving the P3	9
TROUBLESHOOTING.....	10
Troubleshooting Check List	10
Ordering Replacement Parts.....	10
MAINTENANCE	11
NOTES	11
WARRANTY	12

Tables

Height vs. Load Curve	6
Set-up Reference Table	7

List of Figures

Figure 1	Safety Labels	4
Figure 2	Pinch Points	4
Figure 3	Loading Manually	8
Figure 4	Unloading Manually	8
Figure 5	Loading with a Fork Lift	9
Figure 6	Unloading with a Fork Lift	9
Figure 7	Moving the P3	9

INTRODUCTION

The P3 Model is a simple device that will automatically maintain a load at the ideal height for manual loading and unloading. If a palletized load is placed on the unit, the unit gradually rises as boxes or parts are removed. This automatically maintains the top of the load at the correct working height.

The unit may also be used for the reverse application. An empty pallet may be placed on the P3 Model. The unit gradually lowers as boxes or parts are added. Again, this keeps the top of the load at the correct height. Complete pallets may be loaded or unloaded using a fork lift. See Figures 3 & 4.

This manual contains information to help you to learn about the safe and proper installation, use, and upkeep of your P3 unit. Please be sure that this manual is available to anyone who uses or services the P3 Model.

P3 units may be used in a wide variety of industrial settings. The instructions in this manual are not necessarily all-inclusive, as Presto cannot anticipate

all conceivable or unique situations. **In the interest of safety, please read this whole manual carefully. Be familiar with the contents of this manual before you install or use the P3 unit. If you are not sure of the proper procedure to be followed, please call Presto Lifts for more information.**

Presto's product warranty is shown on the rear cover of this manual. **This instruction manual is not intended to be or to create any other warranty, express or implied, including any implied warranty of merchantability or fitness for a particular purpose, all of which are hereby expressly excluded.** As set forth more specifically in the product warranty, Presto's obligation under that warranty is **limited** to the repair or replacement of defective components, which shall be the buyer's **sole remedy**, and Presto shall not be liable for any loss, injury, or damage to persons or property, nor for any direct, indirect, or consequential damage of any kind resulting from the P3 unit.

SAFETY

The P3 unit has been carefully designed to be as safe as possible for operators and service workers. If you take a few common-sense precautions, you will be able to use the unit safely. However, the P3 Model is a powerful unit with moving parts, and is capable of causing personal injury if proper precautions are not taken.

Therefore, throughout this manual, Presto has identified certain hazards which may occur in the use and servicing of the P3 unit, and provided appropriate instructions or precautions which should be taken to avoid these hazards. In some cases, Presto has also pointed out the consequences that may occur if Presto's instructions or precautions are not followed. Presto Lifts uses the following system of identifying the severity of the hazards associated with its products:

DANGER! Immediate hazard which will result in severe personal injury or death.

WARNING! Hazard or unsafe practice which could result in severe personal injury or death.

CAUTION! Hazard or unsafe practice which could result in minor personal injury or property damage.

Please read and follow this instruction manual, including all safety instructions and precautions, carefully and completely.

WARNING!

Do not inflate the system to more than 62 psi at the fully raised position, or 120 psi at any other position. If the actuation system pressure is higher than 120 psi under any circumstance it may cause the failure of the air actuation system thus resulting in severe injury.

WARNING!

Never try to service the machine without carefully reading the maintenance part of this manual. Otherwise severe personal injury may result.

Figure 1 shows the safety labels on this unit. Please be sure that all of the labels are in place, and are visible to the machine operators. Never paint over the labels. If any of the labels are missing, please contact Presto Lifts for replacements. **The safety labels help to protect your workers.**



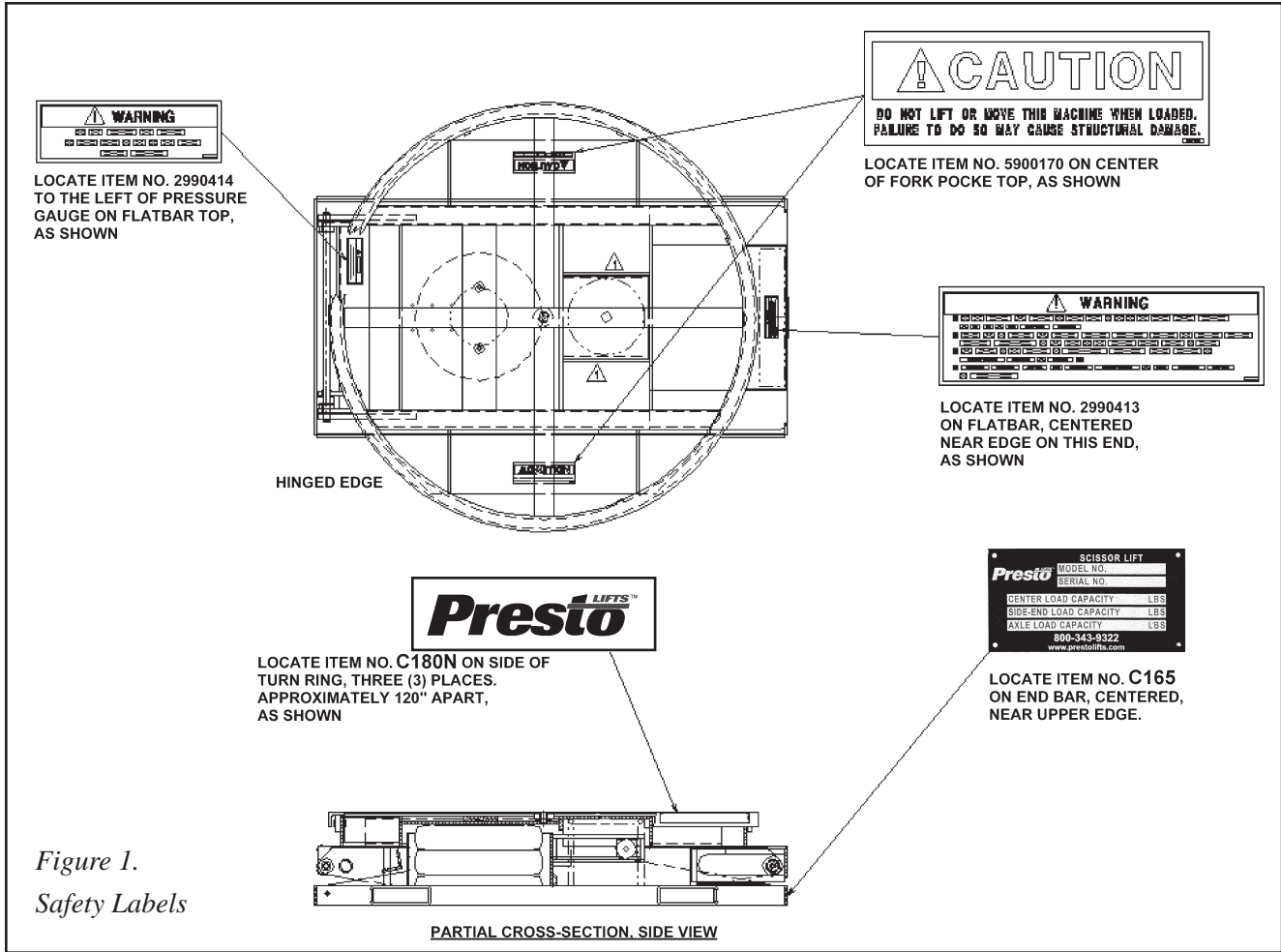
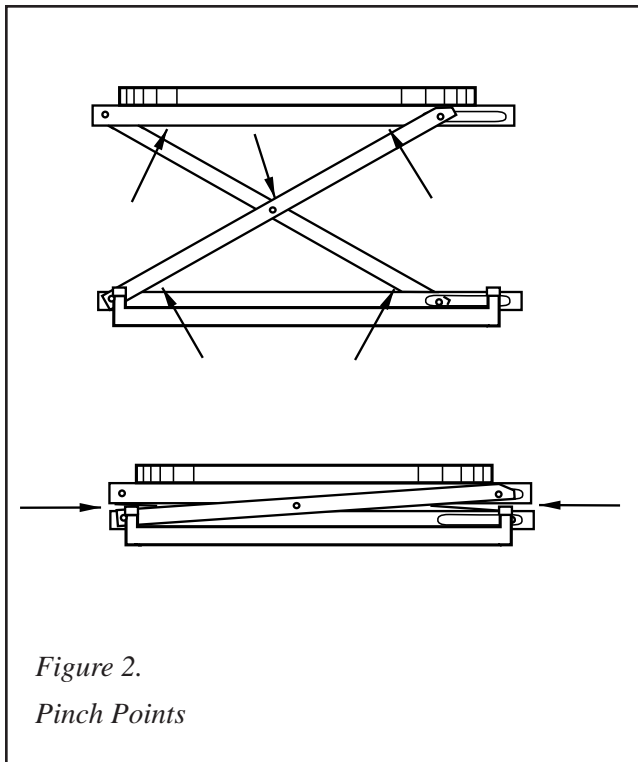

Figure 1.
Safety Labels



INSTALLATION NOTES

WARNING!

The unit is attached to the skid using metal bands. These bands are under high tension. The edges are sharp. Wear safety glasses and gloves when you handle or cut the banding.

NOTICE!

The unit must be installed on a firm level surface. The frame of the unit must sit firmly on the floor, and the floor must be level. If the frame is not supported correctly, stresses may develop in the frame. The unit may bind or not work easily. The rotating top may not rotate correctly.

OPERATION NOTES

Manual Use

WARNING!

Never sit or ride on the turntable or operate the unit if anyone is on it.

WARNING!

Never operate the unit if the load is off center. The load may shift, and you may be injured. This can also damage the unit.

WARNING!

As the unit moves, keep away from the “pinch points” where metal parts meet. See Figure 2.

WARNING!

Keep the area around the unit clean. Do not allow any dirt, debris, spilled oil, or excess grease to collect. These materials may cause you to slip while the unit is operating, and you may be injured.

WARNING!

Stay clear of the turntable when it is moving. As the pallet turns, a part of the load may rotate around and hit you. Never turn the load when anyone is standing beside the unit.

WARNING!

Do not try to use this unit with damaged or broken pallets. Broken pallets may have boards or nails which hang down below the main part of the pallet. As the pallet is turned, these boards or nails may catch on the frame of the unit. This can cause the pallet to stop turning suddenly, causing the load to shift.

You may be injured, and the unit may be damaged. The boards or nails on the bottom of the pallet should not extend down more than 1/8 inch.

CAUTION!

Do not use this unit with a load greater than the rated capacity. This includes the weight of the payload and the weight of the pallet. If you overload the unit, it may be damaged.

INSTALLATION INSTRUCTIONS

Unpacking the Unit

1. Before you start to install the unit, check for local codes and ordinances that may apply. It is your responsibility to obtain any necessary permits.
2. Please read all of these instructions carefully. Be sure to read and understand all of the warnings.
3. Inspect the shipping pallet carefully for any damage which may have affected the unit. If you see signs of damage, notify the shipper immediately. Also make a note of this on the shipping papers that you are asked to sign.
4. Choose the place where you want to mount the unit. It is very important that the P3 Air Level Loader be set up on a smooth and flat surface. Check the floor surface carefully and make sure that it is free of all loose debris and dirt.

Specifications

Load capacity	500 to 4500 lbs.
Load size	50" wide x 50" long x 72" high (max.)
Length	45 1/4 inches
Width (base frame)	36 3/4 inches
Compressed height	9 1/2 inches
Extended height.....	30 1/2 inches
Air Source	62 psi
Maximum system air pressure	120 psi
Safety relief valve setting.....	125 psi
Rotating ring, outside diameter.....	43 5/8 inches
Rotating ring, inside diameter.....	40 5/8 inches
Adjustment for sloping floors.....	Can adjust for floor slope up to 25 using optional adjustable feet
Net weight	300 to 400 lbs
Operating environment.....	indoors
Operating temperature.....	+30 to +120F

Using optional adjustable feet, the unit can compensate for a slightly sloping floor (1:25), but the surface must be smooth and solid.

CAUTION!

The unit must be installed on a smooth flat surface. If the floor is not flat, this can create stresses in the frame of the unit. The unit may not work properly, or parts of the unit may wear more quickly than they should. You may be hurt or the load may be damaged.

5. Position the P3 Model beside the point where the unit will be setup.

WARNING!

The unit is attached to the skid using metal bands. These bands are under high tension. The edges are sharp. Wear safety glasses and gloves when you handle or cut the banding.

6. Remove the metal banding that secures the unit to the pallet. Remove all packing material. Shift the unit to the floor. Support the base as you do this.
7. Check to see that the frame of the unit is sitting firmly on the floor. Try to move or rock the frame of the unit. The base frame should be stable, and should not move. Check to see that the base frame is level. (If any part of the frame is more than 1/2" out of level in relation to any other part, you must

install the optional adjustable feet to level the unit. See the instructions which follow.)

8. If you have any questions about the steps in the installation process, please call Customer Service at 1-800-343-9322.

SET-UP and INSTRUCTIONS

The P3 Model can be setup to handle pallet loads of any weight within the unit's capacity range. Load capacity depends on the initial actuator pressure. The actuator pressure can be set from 62 psi to 6 psi to achieve capacities ranging from approximately 500 lbs to 4500 lbs. Either an air compressor or shop air can be used as the air source to setup the unit. Maximum air pressure needed from the air source is 62 psi. Once air is inflated into and kept captive within the unit's air actuation system, a corresponding load capacity has been set. The unit will then lower or rise as the load is being added or removed from the unit, and thus works as an automatic pallet leveler. A rule of thumb for setting up the unit is that the amount of air inflated into the air actuator should allow the unit to be lowered to its compressed height with load equal to 75% of the set capacity (including the weight of the pallet). The Height vs. Load Curve below describes the automatic leveling behavior and the Capacity-setting Table can be used to estimate the initial pressure in setting up the unit to a specific capacity.

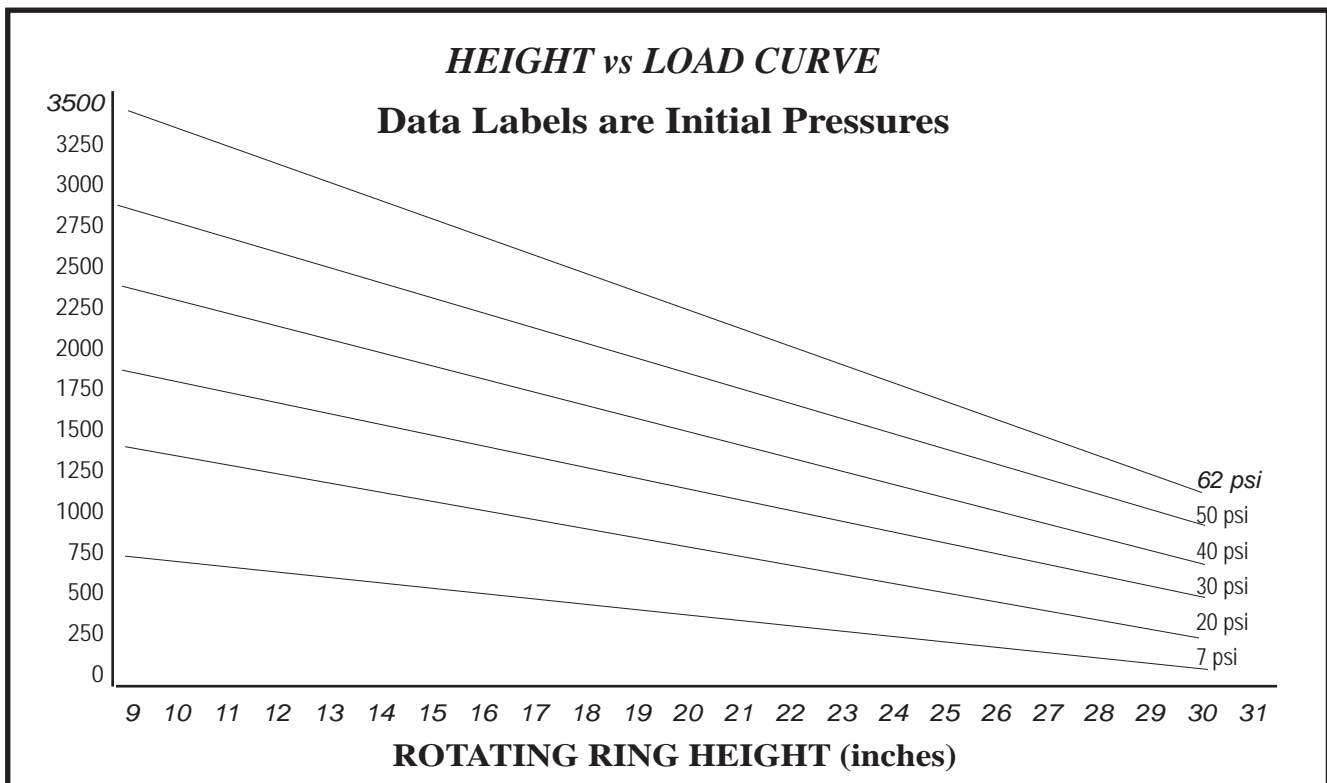

SET-UP REFERENCE TABLE

Capacity (lbs.)	<700	1000	1500	2000	2500	3000	3500	4000	4500
Capacity X 75%		750	1125	1500	1875	2250	2625	3000	3375
Initial Pressure (psi)	7	11	18	26	34	42	49	56	62

SET-UP PROCEDURES

1. The P3 Model must be properly installed according to the installation section of this manual.
2. Use the Set-up Reference Table to find the initial pressure. As an example, if the desired capacity is 3000 lbs, from the Set-up Reference Table, find the load that should compress the unit that is 75% of the capacity, or 2250 lbs. Also find the initial air pressure that the air actuator should be inflated to. In this example the initial pressure is 42 psi. If the capacity desired is not exactly shown in the table, use the next higher capacity rating in the table. The initial pressure is just an estimate; it does not matter if the estimate is a little higher than necessary. *However, the initial pressure does not need to be, and should never be, more than 62 psi (the maximum is 62 psi).*
3. With no load on the unit use shop air or an air compressor to pressurize the air actuation system to the required initial pressure. If the shop air is used, set the air regulator to the required initial pressure. The unit is equipped with an air pressure gauge and an air manifold valve that includes a valve stem, a

manual relief knob, and a safety relief valve. Add air to the actuator system through the valve stem, and release air from the system by loosening the manual relief valve.

4. Gradually load the P3 Model to 75% of the set-up capacity. In our example, the load including the pallet is 2250 lbs. Check to see if the P3 Model is compressed. If not, turn the manual relief knob to slowly bleed air out of the system until the platform reaches minimum height. Then turn the manual relief knob to shut off the relief. The set-up procedure is now complete and the P3 Model is ready for use.
5. If a different load is to be handled, or if the operator prefers a higher or lower loading/unloading position from that of the standard set-up, add air to, or bleed air from the actuation system to achieve the necessary height. The gauge should never be more than 120 psi under any circumstances.

** NOTE: The actuation system of the P3 Model contains captive air much like an automotive tire and will lose small amounts of air over time. Therefore, air may have to be occasionally added to the system to compensate for the loss.*

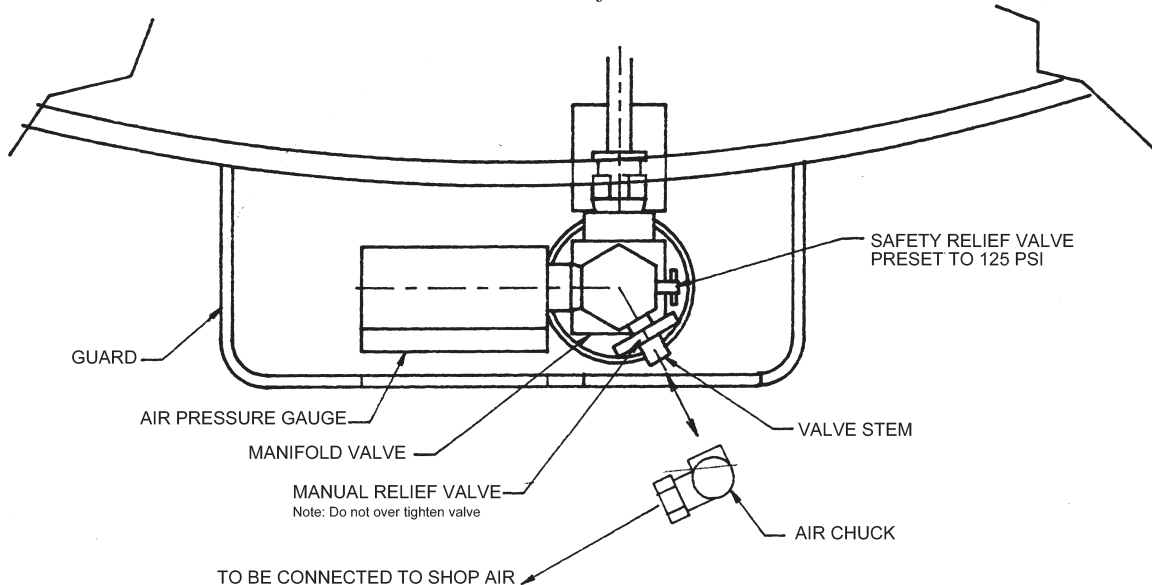

QUICK SET-UP

If you do not know or cannot estimate the weight of the pallet load to be handled, use the following instructions:

With no load on the unit, pressurize the actuation system to 62 psi. Place about half of the pallet load onto the unit, then slowly bleed air from the system using the manual relieve knob until the pallet reaches the most convenient height for the operator to continue loading the pallet.

OPERATING INSTRUCTIONS

Loading Manually

Add boxes or parts until the pallet is full. The unit will gradually lower the pallet until it reaches the bottom. See Figure 3.

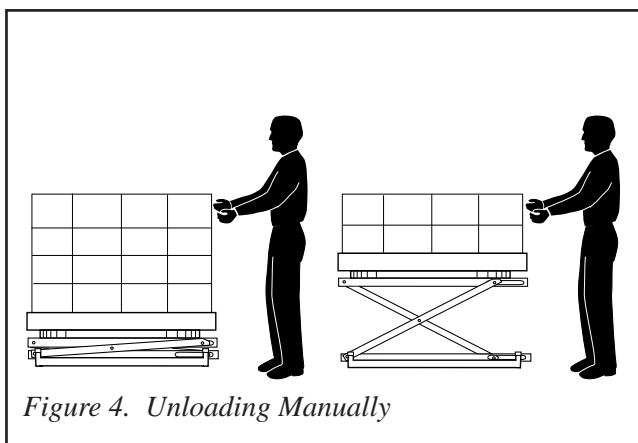
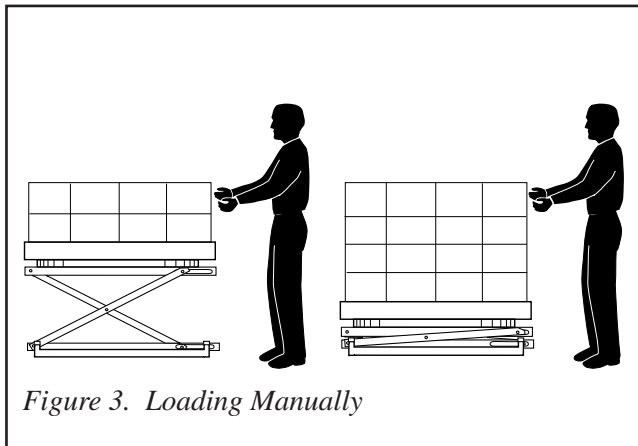

Removing Loads Manually

Remove boxes or parts until the pallet is empty. The unit will gradually raise the pallet. See Figure 4.

WARNING!

Ensure that loading and unloading of the P3 Air Level Loader is done in even layers. Loading or unloading a load on one side may cause the load to tip over and you may be injured. This can also damage the unit.

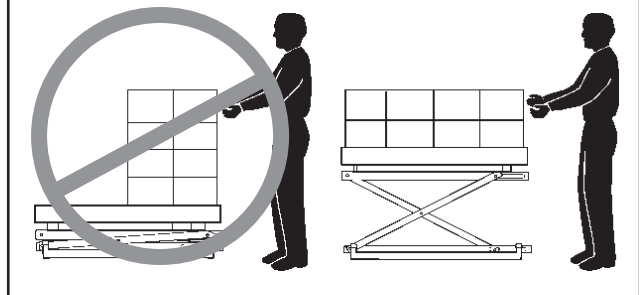

Operating Safety -- Manual Use

1. Do not use this unit with a load greater than the rated load. This includes the weight of the payload and the weight of the pallet. If you overload the unit, it may be damaged.
2. Never push the load off of the side of the unit. If you do this, the frame of the unit may jump upward.
3. Never use the unit when anyone is sitting or riding on the turntable.
4. Do not try to use this unit with damaged or broken pallets. Broken pallets may have boards or nails which hang down below the main part of the pallet. As the pallet is turned, these boards or nails may catch on the frame. The pallet may stop turning suddenly and this can cause the load to shift. You may be injured and the unit may be damaged. If the boards or nails on the bottom of the pallet extend down more than $\frac{1}{8}$ inch, they will interfere with the turning action.
5. Stay clear of the turntable when it is moving. As the pallet turns, a part of the load may rotate around and hit you.
6. Keep the area around the unit clean. Do not allow any dirt, debris, spilled oil, or excess grease to collect. These materials may cause you to slip while the unit is operating and you may be injured.

Loading with a Fork Lift

Figure 5. Loading with a Fork Lift

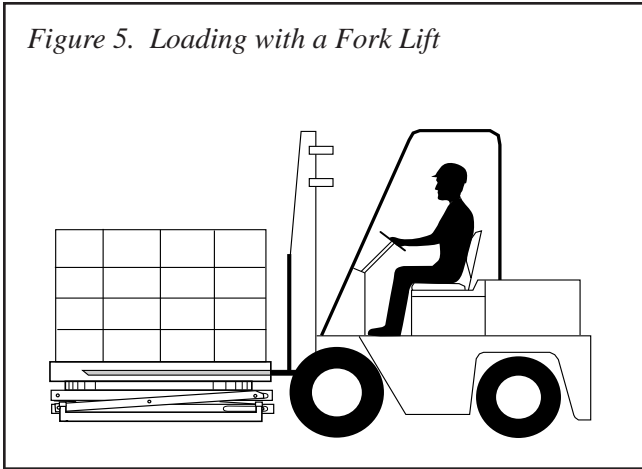

1. Place the load on the lift, then lower the fork lift. Before removing the load, be sure the unit is carrying the weight, not the fork lift. See Figure 5.

- Lower the load until the springs on the P3 Model are fully compressed.
- Be sure the forks on the lift are clear of the inside of the pallet.

WARNING!

If you skip these steps, the load may drop suddenly when you remove the fork lift. You may be hurt or the unit or load may be damaged.

WARNING!

Never drop the load on the turntable. If you do this while the turntable is moving, the load may shift. You may be injured or the unit may be damaged. If you drop the load while the turntable is stopped, the unit may be damaged.

2. Be sure the load is centered on the unit.

WARNING!

If the load is off-center, it may shift when the turntable is turned. You may be hurt or the unit or load may be damaged.

Unloading with a Fork Lift

1. Insert the forks into the pallet, and lift the pallet clear of the top of the unit. See Figure 6.

- Be sure the pallet clears the top of the turntable before you move the fork lift.

WARNING!

If you skip these steps, the unit may jump up suddenly when you remove the pallet. You may be hurt or the unit or load may be damaged.

Moving the P3

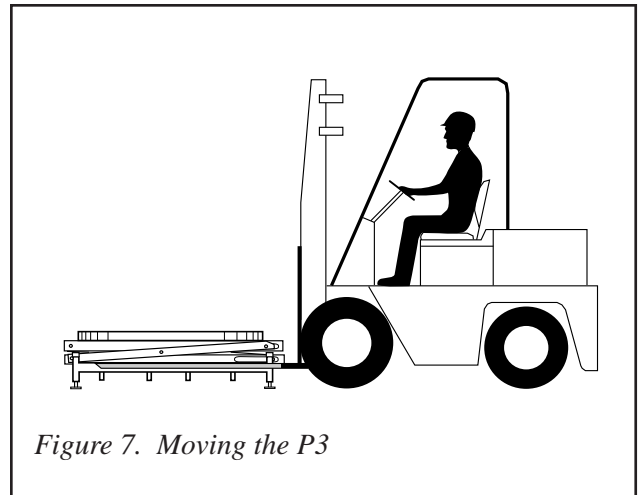

Figure 7. Moving the P3

CAUTION!

Do not move the P3 unit while it is loaded. This will damage the base frame of the unit. The pockets on the base frame are designed to support an unloaded unit, but cannot support any extra weight.

1. Remove any load from the top of the P3 unit.
2. Insert the forks into the pockets in the base frame. See Figure 7.

Figure 6. Unloading with a Fork Lift

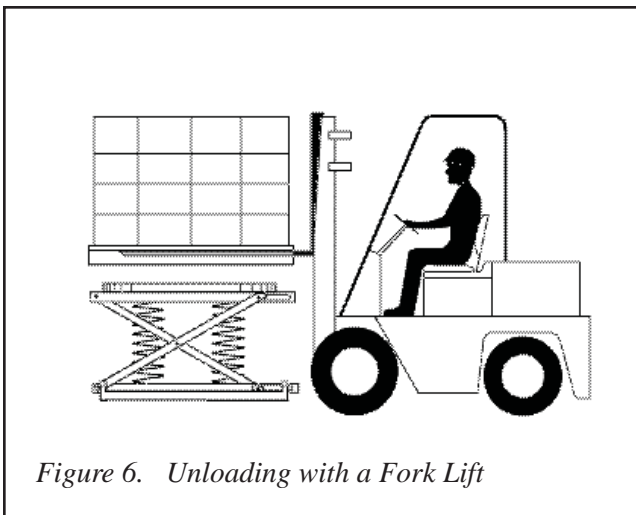

Troubleshooting

Troubleshooting Check List		
<i>Problem</i>	<i>Possible Cause</i>	<i>Check This</i>
The top of the unit rotates from you.	The frame of the unit may not be level.	Move the unit to a level surface or away install the optional adjusting feet.
Excessive “rumble” when unit operates.	Wear or lack of lubrication to bearings under turntable.	Remove turntable, replace bearings.
Wear on underside of turntable.	Normal condition caused by wear-hardening of metal.	No repair necessary.

Component Identification

	Qty	Description
1.	1	Air manifold
2.	1	Air gauge
3.	6	Upper & lower rollers
4.	2	Center pivot bushing , outer
5.	4	Upper hinge bushing
6.	2	Lower hinge bushing
7.	4	Center pivot bushing, inner
8.	1	Turntable bushing
9.	1	Air chuck
10.	8	Turntable bearings

Please call the Presto Parts Department at 1-800-343-9322 for pricing and part numbers.

Maintenance

Routine Periodic Maintenance

Every 90 days -

- Apply grease or heavy oil to the pivot shafts.
- Check for loose hardware and signs of excessive wear or binding.
- Check to be sure that the unit is placed on a firm level surface.

If the optional adjustable feet are installed, be sure that all four feet are touching the floor and are locked in position.

Ordering Replacement Parts

Presto Lifts has carefully chosen the components in your unit to be the best available for the purpose. Replacement parts should be identical to the original equipment. Presto Lifts will not be responsible for equipment failures resulting from the use of incorrect replacement parts or from unauthorized modifications to the unit.

Presto Lifts can supply all replacement parts for your P3 Model. With your order, please include the model number and the serial number of the unit. You can find these numbers on the name plate. This plate is located within the scissors mechanism.

To order replacement parts, please call the Presto Parts Department. Parts are shipped subject to the following terms:

- FOB factory
- Returns only with the approval of our parts department.
- Payment net 30 days (except parts covered by warranty).
- Freight collect (except parts covered by warranty).

Parts replaced under warranty are on a "charge-credit" basis. We will invoice you when we ship the replacement part, then credit you when you return the worn or damaged part.

Presto Parts Department

21 Park Street
Attleboro, MA 02703

Telephone: 800-343-9322

FAX: 888-788-6496

Email: service@PrestoLifts.com

www.PrestoLifts.com

Presto Lifts Limited Warranty Policy

Presto Lifts warrants all of its products against defects in the welded structural frame and, if applicable, scissor legs from faulty material and workmanship for a period of five (5) years from the date of invoice.

A lifetime limited warranty is provided for the Airstroke Actuator™ in all pneumatic lifts against any defect due to faulty material or workmanship.

All other components have a limited warranty against defects in faulty material and workmanship for a two (2) year period from the date of invoice date of invoice and 30 day limited warranty on labor. Please note that prior authorization from Presto Lifts is required on all warranty work.

There are no implied warranties of any kind, more specifically, there are no warranties of merchantability or fitness for any particular purpose. Presto Lifts' sole warranty shall be as set forth in this limited warranty.

Presto Lifts will elect to repair or replace a defective component without charge, if any components should become defective within the limited warranty period. Proof of purchase is required for warranty. The charge for shipping the defective component is the responsibility of the buyer and must be accompanied with an RMA number. The shipping charge to return the component to the buyer is the responsibility of Presto Lifts, Inc.

This limited warranty does not cover labor expense for removal or reinstallation of components after thirty days. This limited warranty shall not cover, among other things: damages resulting from foreign matter or water, failure to provide reasonable and necessary maintenance or failure to follow operating instructions. The limited warranty is not valid for damage resulting from negligence, accident, unreasonable use, abuse or misuse, exceeding data plate capacities or altering the product without Presto Lifts authorization.

Presto Lifts expressly disclaims and excludes any liability for consequential, incidental, indirect or punitive damages or financial loss to people or property resulting from any breach of warranty or the operation or failure of this product.

Presto Lifts makes no representation that this product complies with local, state, or federal safety/product standards codes. Should this product fail to comply in any way with those codes, it shall not be considered a defect of materials or workmanship. Presto Lifts shall not be held liable for any damages resulting from noncompliance. It is the dealer's responsibility to exercise this limited warranty. This limited warranty is provided to the original purchaser (defined as the original end user) and is nontransferable. This constitutes the complete and final agreement involving Presto Lifts and limited warranty obligations for products.

Go Presto LIFTS™

MANY NEEDS REQUIRE
MANY OPTIONS...



Lift
Stik



Post
Tables



Double Lift
Table



Lift
Table



Portable
Lift



P3



Counterweight
Stacker



Pallet
Jack



Pneumatic
Lift/Tilt

Call Presto Sales
for stock or customized lift inquiries at

800-343-9322

Email: sales@prestolifts.com



Portable
Tilter



Floor Level
Lift



Stacker