

# 1 Drawer at-a-time Mechanism R Line

Assembly Guide



# Mécanisme 1-à-la-fois Ligne R

Guide d'assemblage

- All required hardware is included.
- Please check the contents with your packing slip.
- Read instructions carefully.
- Save this document for future reference.

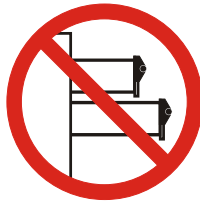

- Toute la quincaillerie requise est incluse.
- Veuillez vérifier le contenu avec votre feuille de livraison.
- Lisez attentivement les instructions.
- Conservez ces instructions pour référence future.

## Hardware

Tapping screw  
Vis taraudeuse  
3D1616L2



Glide  
Glissière  
71019300

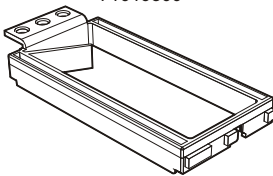

Runner  
Coulisseau  
71019600

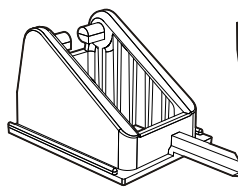

## Quincaillerie

Locking block  
Bloc d'activation  
71019000

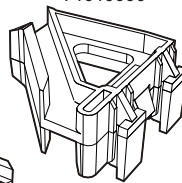

## Tools Required Outils requis



Note :

It's possible you can have too much plastic pieces depending of number of drawer your cabinet have.  
*Il peut y avoir des pièces en plastique en trop selon le nombre de tiroirs dans votre cabinet.*

## Locking Block Assembly

## Assemblage du bloc d'activation

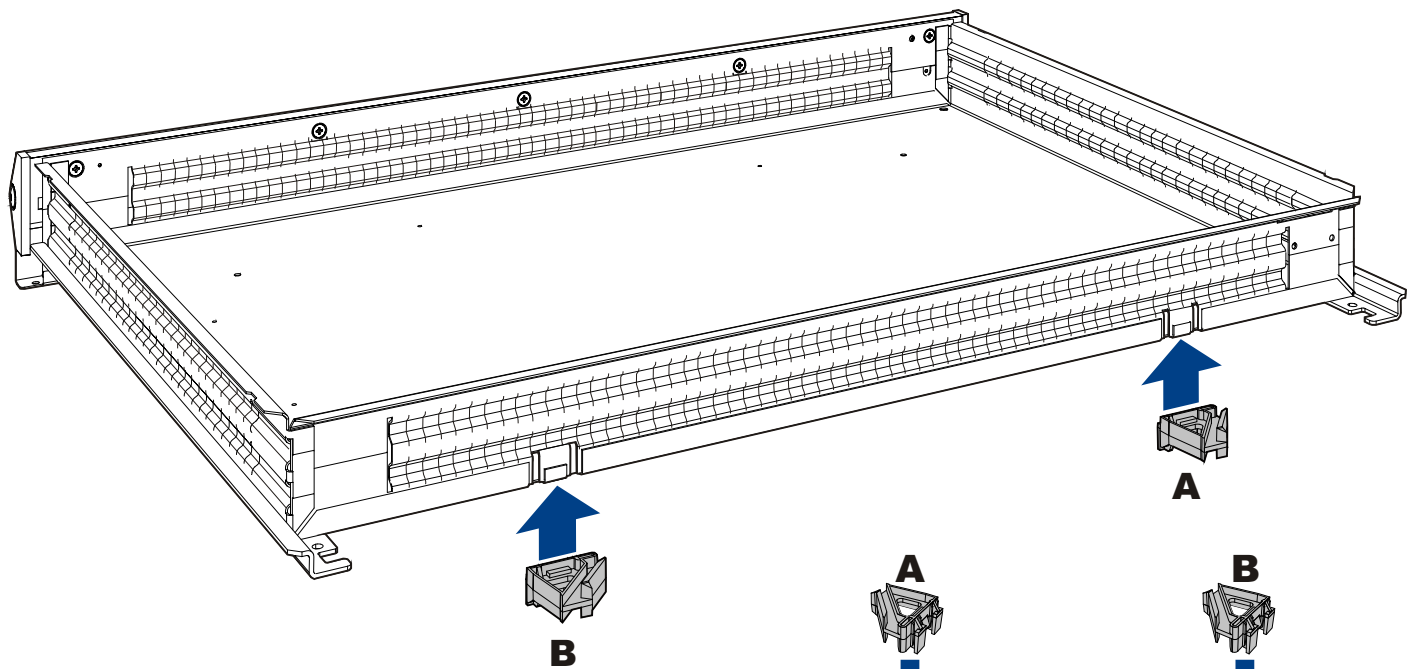

- For regular cabinet, install all locking blocks in position "B".
- For multi-drawer cabinet, install all locking blocks in position "A" and "B" as illustrated.
- Pour les cabinet régulier, installer tous les blocs d'activation dans la position "B".
- Pour les cabinets multi-tiroirs, installer tous les blocs d'activation dans la position "A" et "B", tel qu'illustré.

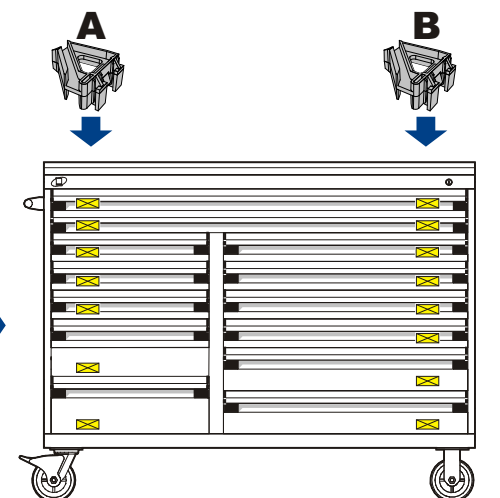

2x  3/8"

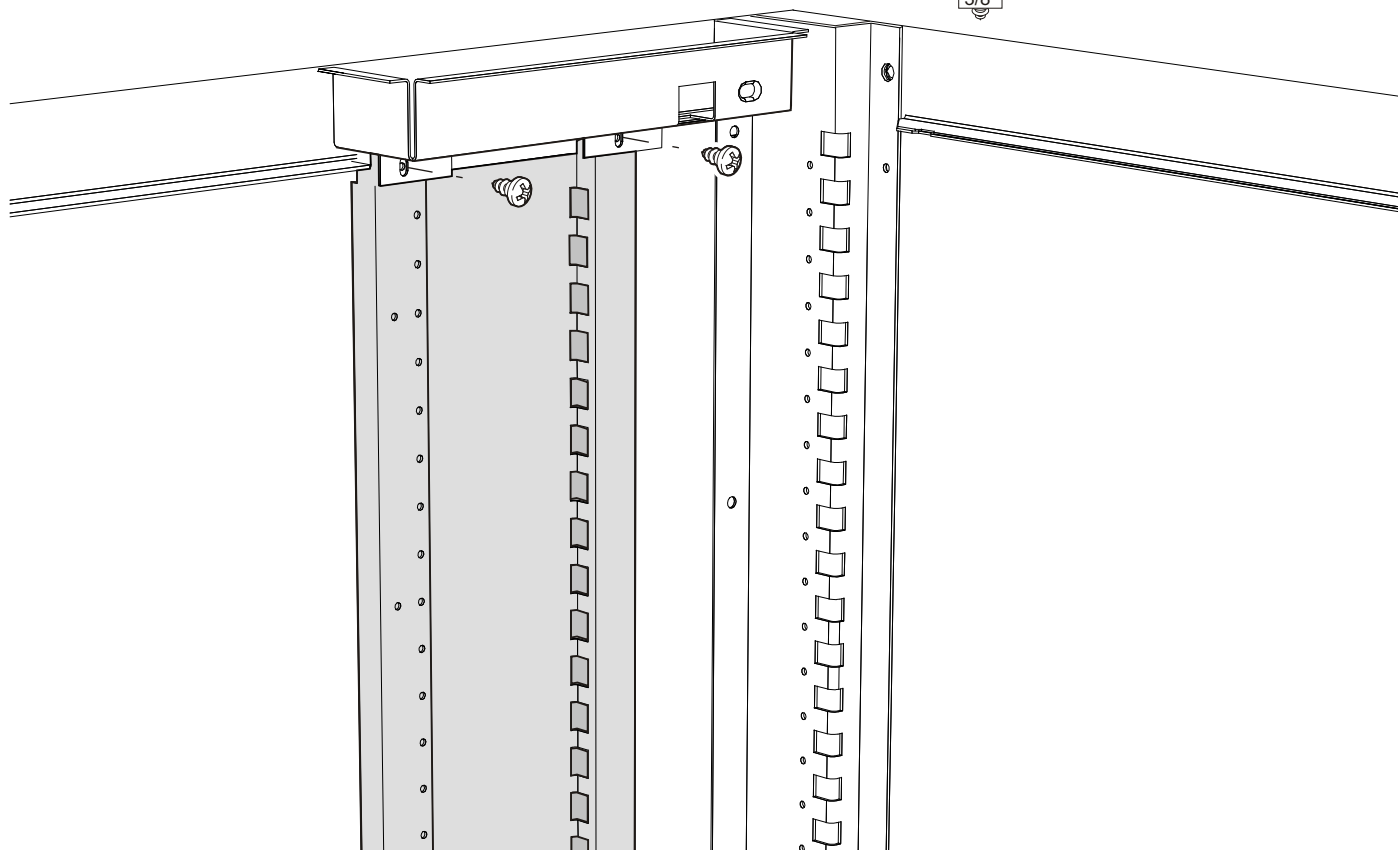

 3/8"

2 per drawer / par tiroir

