

Bumper Rack WM Line

Assembly Guide



Structure à recouvres-pare-choc Ligne WM

Guide d'assemblage

- All required hardware is included.
- Please check the contents with your packing slip.
- Read instructions carefully.
- Save this document for future reference.
- Two people are required for the assembly.

- Toute la quincaillerie requise est incluse.
- Veuillez vérifier le contenu avec votre feuille de livraison.
- Lisez attentivement les instructions.
- Conservez ces instructions pour référence future.
- Deux personnes sont requises pour l'assemblage.

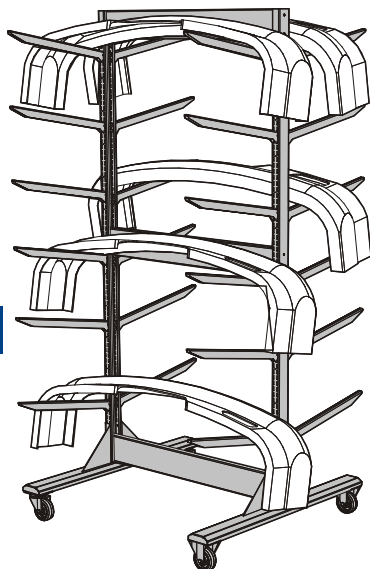

Hardware

Quincaillerie

5/16-18 nylon locknuts
Écrous nylon 5/16-18
3S2003Z2

5/16-18 bolts
Boulons 5/16-18
3L120202



Lock Washer
Rondelle ressort
3Z032012

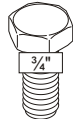

Tools Required

Outils requis

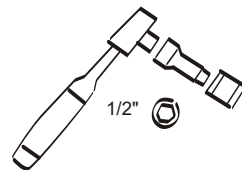

Structure assembly

Assemblage de la structure

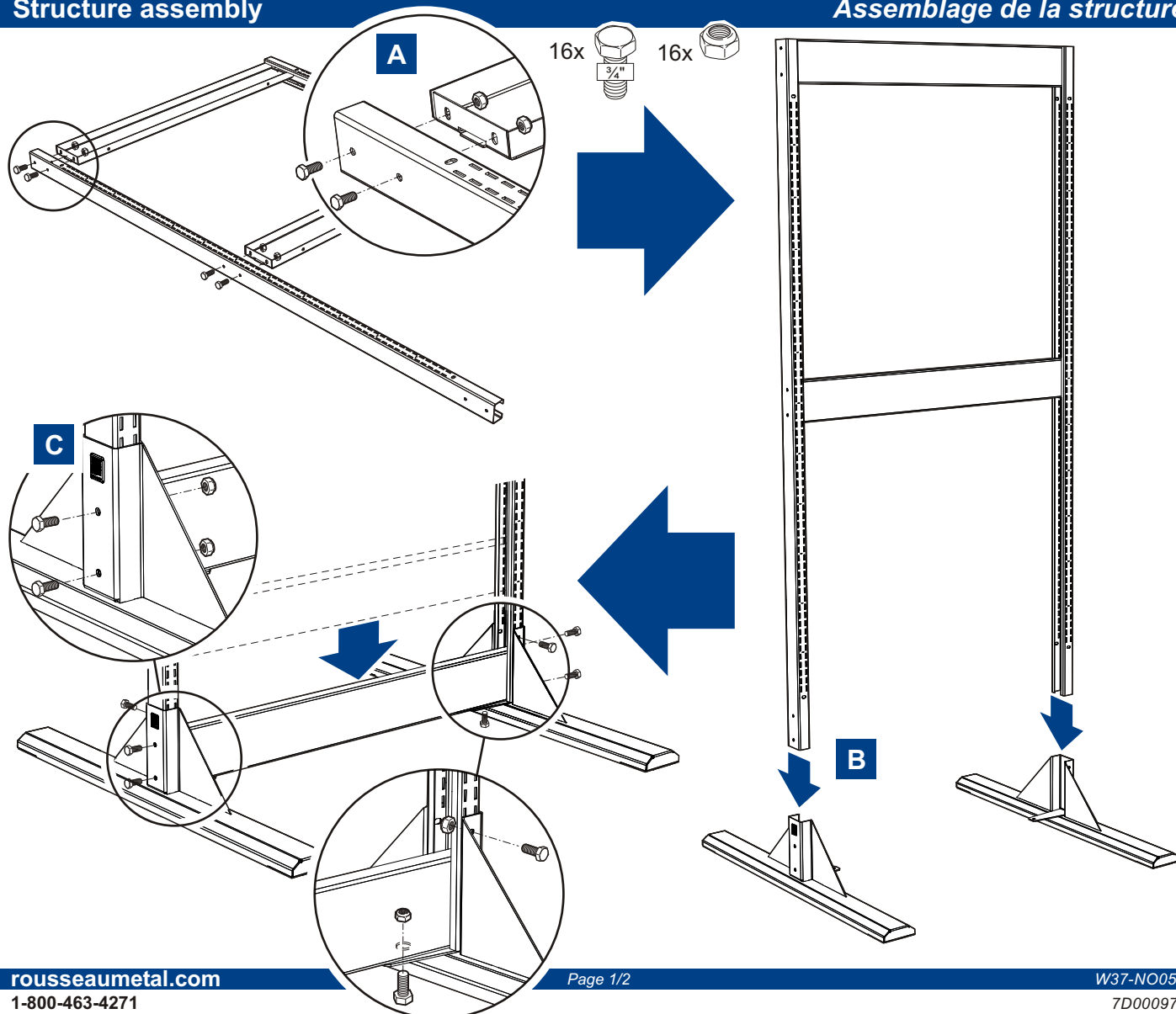

Casters

Roulettes

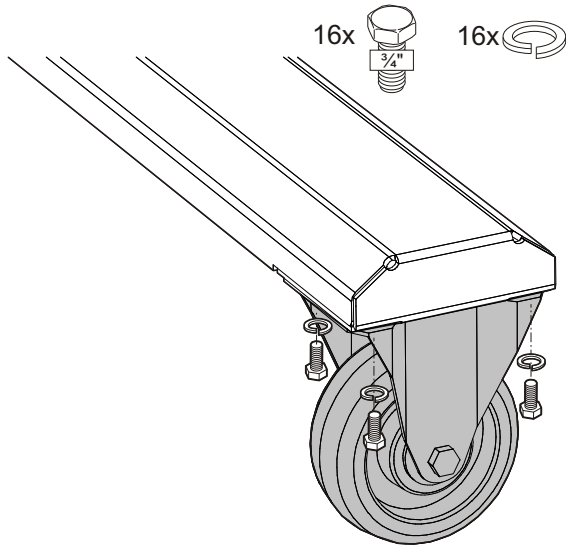

Leveling glides

Patins niveleurs

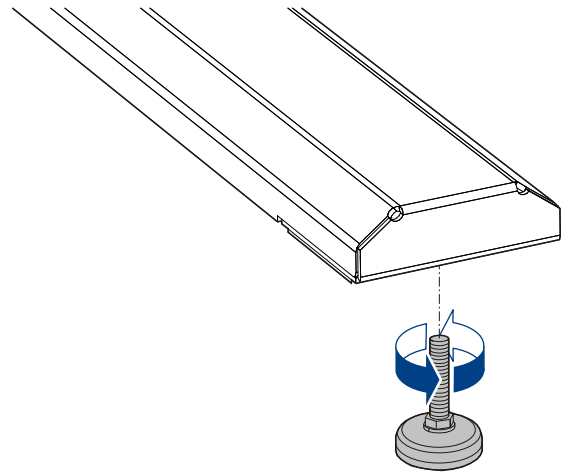

Bumper Supports

Support à recouvrement pare-choc

