

Packaging Components WM Line

Assembly Guide



Composantes d'emballage Guide d'assemblage Ligne WM

- First check the contents.
- Read instructions carefully.
- Save this document for future reference.

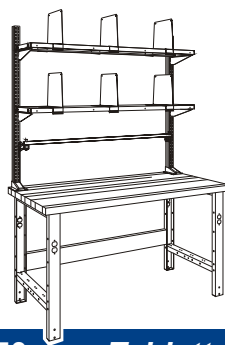

- Commencez par vérifier le contenu.
- Lisez attentivement les instructions.
- Conservez ces instructions pour référence future.

Packaging Structural Shelf WM27+WS50

Tablette pour poste d'emballage WM27+WS50

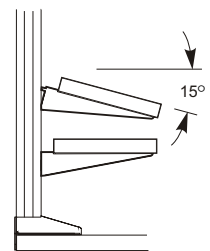
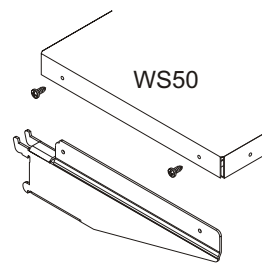
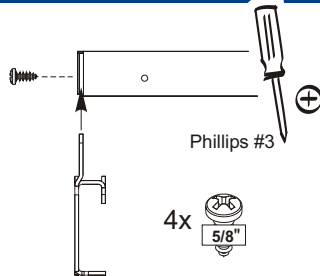
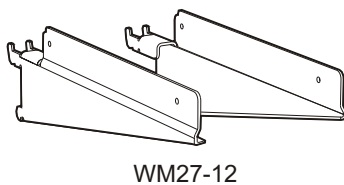

Paper/Cardboard roll support WM86

Support à rouleau de papier/carton WM86

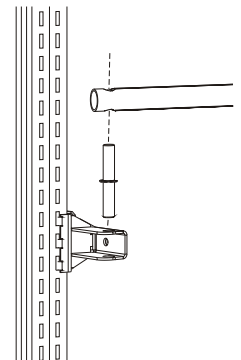
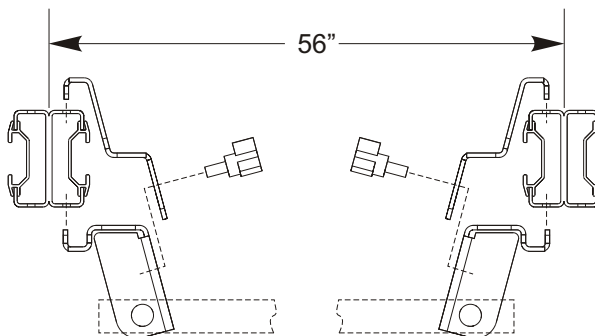
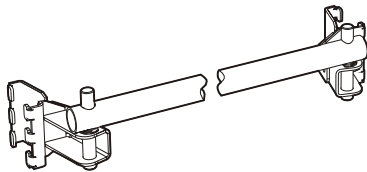

Paper/Cardboard roll support WS86

Support à rouleau de papier/carton WS86

