

SK2000[®] – Boltless Pallet Rack Installation and Assembly Guide



Steel King Industries, Inc.

2700 Chamber St

Stevens Pont, WI 54481

(800) 826-0203

www.steelking.com

info@steelking.com

ASSEMBLY INSTRUCTIONS:

Steel King Industries recommends that this product be assembled only by qualified personnel, experienced in assembly of storage racks, and knowledgeable of all safety regulations and practices. These instructions are intended only for use by qualified individuals using all proper safety equipment.



These storage racks are extremely heavy, and if not properly secured during installation and assembly could fall, possibly causing injury or death as well as damage to property.

Contact Steel King Industries or your local Steel King Representative for the name and contact information of a qualified installer. Users of this information agree to indemnify and hold harmless Steel King Industries from any and all liability.

Installation Note: Do not install racks outdoors, unless specifically designed by Steel King for this purpose. Outdoor usage requires consideration of wind loads, snow loads, etc., which are not normally considered in rack design.

Pallet Rack User's Manual

Steel King Industries recommends that all users of Steel King manufactured storage racks obtain, read and understand Steel King's **Pallet Rack User's Manual**. Copies of Steel King's Pallet Rack User's Manual are free of charge and can be obtained by contacting Steel King Industries at:

Steel King Industries Inc
2700 Chamber St
Stevens Point, WI 54481
(800) 826-0203
info@steelking.com

Electronic versions are available at: www.steelking.com/safetyinfo

Step #1: Check the Material

- A. Check to make certain that all materials have been received. Materials should be checked against the packing lists and Bill of Lading.
- B. Notify the shipper immediately of any shortages or product damage.

Step #2: Check the Area:

- A. Clear the area where the rack system is to be located.
- B. Check the area for all obstructions, such as lights, heating ducts, pipes, building columns, etc., to insure a clear area for the installation of the storage rack.

Step #3: Lay Out floor:

Recommended tools:

- Tape Measure
- Chalk Line

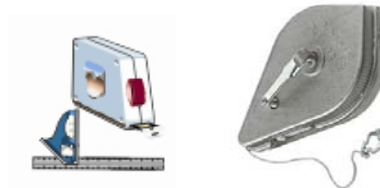

- A. Establish the rack lay out by determining the aisle dimensions and the rack position.

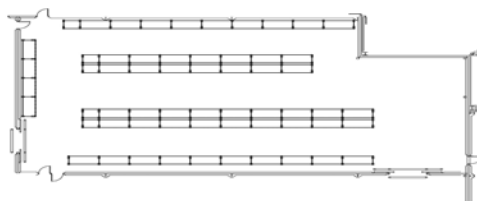

- B. Snap a chalk line establishing the front edge of the upright bases. The chalk line should run the entire length of the row of rack.

Step #4: Assemble First Bay:

Recommended Tools

- Lift truck

- Stand up two upright frames and separate by the length of the load beams.
- Mark the desired height of the first load beam on the face of each upright frame.
- Place rivets from beam clips into top of tear drop holes (wider part of hole) on face of upright frames. Slide beam downward into tear drop holes until completely seated and **safety clip engages**.

See figure below.

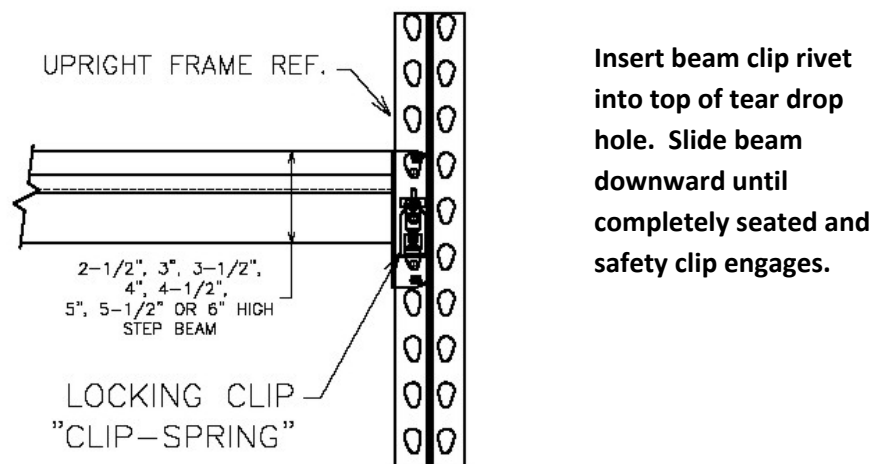

BOLTLESS CONNECTION OF STEP BEAM
(SBR) TO ROLLFORM UPRIGHT (RTF)

- Install second beam on the opposite side of upright frames, at the identical height of first beam.

Step #4: Assemble First Bay Continued:

- E. Move and align bay so that front edge of upright bases is on chalk line.

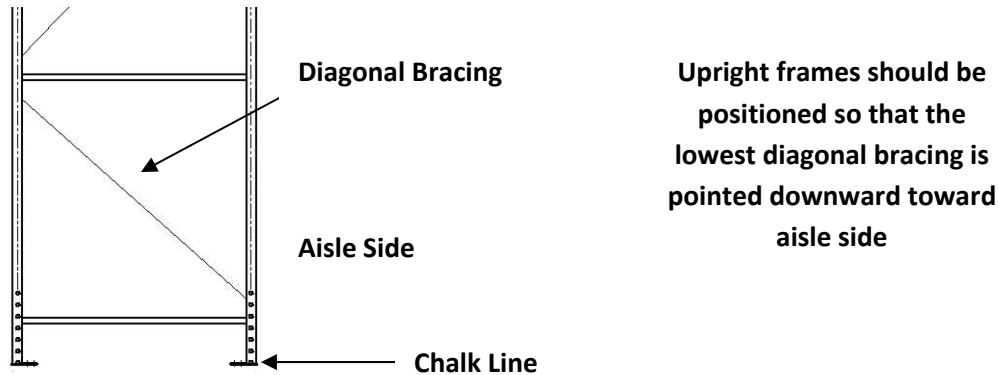

- F. Install subsequent beam levels from the lowest level to the highest level.

Note: It is recommended that a lift truck be used to stand and position frames.

Step #5: Shim, Plumb, and Anchor:

Recommended tools:

- Level,
- Air compressor,
- 3/4" drive impacts or equivalent

- A. Make sure that the bay is square and plumb before anchoring.

Plumb Note: It is very important that the rack structure be installed in a plumb, level, and square condition. Since few floors are perfectly flat, shimming of the racks is frequently required. A four foot long carpenter's level is a good choice for checking level and plumb conditions on storage racks of average proportions. A vertical tolerance of 1/8" in 4 feet (or other as specified on Steel King installation drawings) is generally acceptable.

Step #5: Shim, Plumb, and Anchor Continued:

- B. Use shims as required. Shims are available in 1/8" and 1/16" thicknesses.
- C. The first bay of each row must be anchored to the floor to insure proper placement of the rack to the floor layout.
- D. Each upright frame has 2 footplates, each with 2 anchor holes for floor anchoring. Under normal (non-seismic) circumstances, only 1 anchor is required for each footplate.

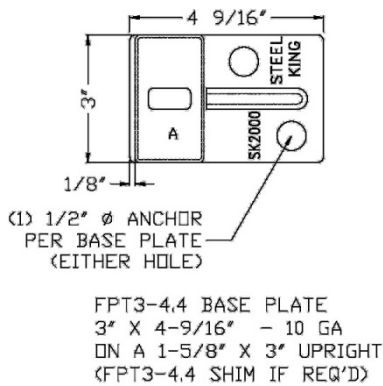
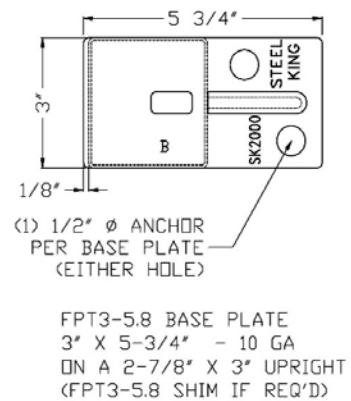
Non-Seismic Anchoring Diagrams**1- 5/8" x 3" wide Upright Column****3" X 3" wide Upright Column**

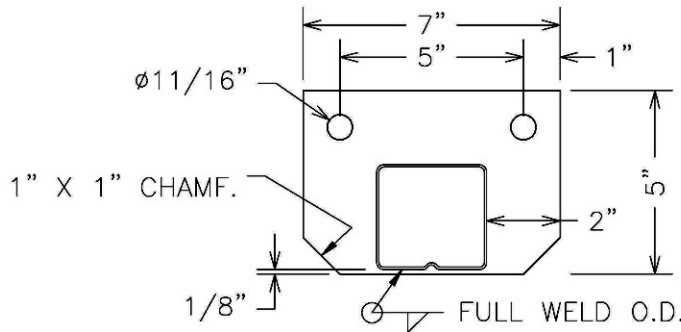
Step #5: Shim, Plumb, and Anchor Continued:**Seismic Anchoring Diagrams****3" x 3" wide Upright Column****5" x 7" x 3/8" Base Plate or
5" x 7" x 1/2" Base Plate****(2) 1/2" x 4-1/2" I.C.C Approved
Anchors per Base Plate**

3/8 BASEPLATE: FPOC (STK)
 10 GA. SHIM: FPBS (STK)

Anchoring Notes:

- Every column of each rack frame must be anchored to an adequate concrete floor.
- The normal anchor connection is (1) one 1/2" diameter x 3-3/4" concrete expansion anchor per column footpad, or as indicated on the Steel King installation drawings.
- **Seismic uprights, those with 5" x 7" base plates, utilize (2) two 1/2" diameter x 4 1/2" I.C.C. approved concrete expansion anchors per column footpad.**
- Anchor bolts are not included with Steel King rack systems unless specifically detailed on the Bill of Materials.
- Since anchor bolts vary in strength, if you are purchasing your own anchor bolts, contact Steel King or your Steel King Distributor for minimum anchor specifications for your installation.
- Since concrete floors vary greatly in design and load carrying capacity, Steel King cannot guarantee that a particular concrete slab is adequate to support a particular rack installation. The characteristics of the slab should be obtained from the building architect before the racks are specified, so that the rack supplier can design the rack to suit the slab.

Step #6: Install Remaining Bays:

- A. Follow the same procedure as Step #4 using common upright frames for each bay.

Step #7: Accessories:

- A. When row spacers are required, each component must have (1) $\frac{1}{2}$ " diameter x 3 $\frac{3}{4}$ " bolt and $\frac{1}{2}$ " nut per connection.

Use a minimum of (2) row spacers up to 120" high, (3) up to 216" high and (4) up to 312" high. Vertical placement of row spacers should be in line with upright column's horizontal bracings.

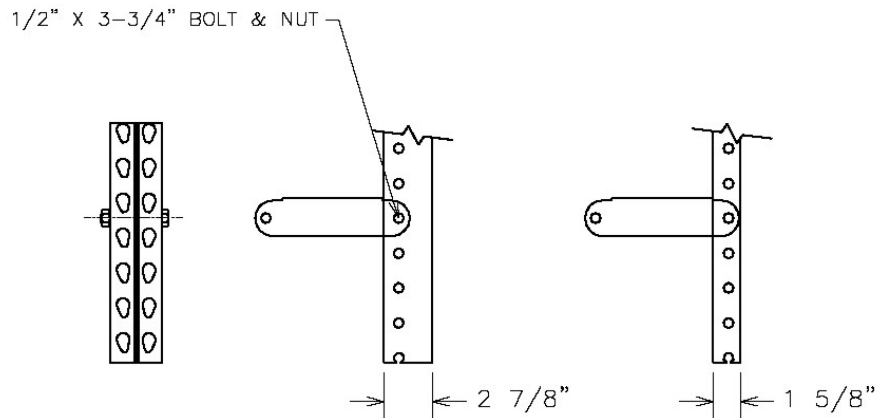

BOLTED CONNECTION OF
ROW SPACER (RSR) TO
ROLLFORM UPRIGHT (RTF)

Step #7: Accessories Continued:

B. The pallet supports are installed with one tek screw on each end.

Hat Style (PSH part numbers) Pallet Supports

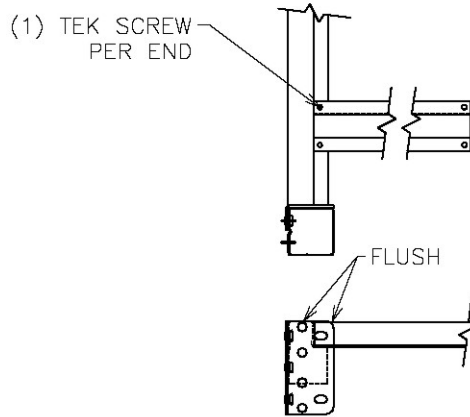

TEK-SCREWED CONNECTION OF
HAT-SHAPED PALLET SUPPORT (PSH)
TO STEP BEAM (SBR)

Waterfall (PSW part numbers) Pallet Supports

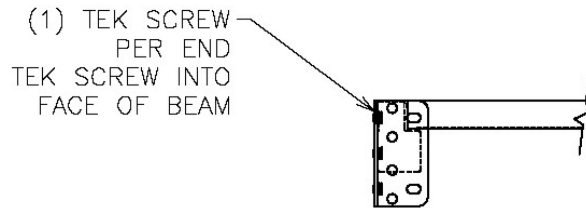

TEK-SCREWED CONNECTION OF
WATERFALL PALLET SUPPORT (PSW)
TO STEP BEAM (SBR)

C. Tighten all accessory nuts and bolts (row spacers) and double check anchor connections to complete the installation process.

Capacity Plate Note: Installation of "capacity plates" is strongly recommended. These plates should identify the characteristics for which the rack was designed, such as load size, load weight, and rack configuration. These plates are very useful for communicating safe loading information to both present and future users. Several signs should be prominently located for easy visibility, and be permanently affixed to the rack structure. Appropriate signs can be obtained locally, through industrial mail order catalogs, or from Steel King or your Steel King Distributor.



Step #8: Clean-up:

- A. Dispose of all dunnage, strapping and debris. Sweep the floor with a broom if necessary.

Determining Storage Rack Capacity

To determine the load capacity of your storage rack:

- A. Determine the maximum distances between shelf/beam levels.
- B. Determine the distance from the floor to the first shelf/beam level.
- C. Compare distances computed in Steps A & B; use whichever figure is greater as the Maximum Vertical Beam Spacing in the chart below.

Steel King Upright Frames				
Upright Frame Post Type	RTFAG	RTFBG	RTFBG-SEISMIC	RTFBW-SEISMIC
Post Width	3 Inches	3 Inches	3 Inches	3 Inches
Maximum Vertical Beam Spacing:	Capacity (pounds)			
48"	21,860#	31,420#	Capacity ratings for seismic frames are based on installation location, upright height and vertical beam spacing. Please consult Steel King.	
54"	19,440#	28,490#		
60"	17,050#	25,530#		
66"	14,740#	22,600#		
72"	12,540#	19,770#		
78"	10,700#	17,050#		
84"	9,250#	14,740#		
90"	8,060#	12,870#		
96"	7,100#	11,330#		
Over 96"	Consult Steel King			

Chart Notes:

- 1) Capacities based upon interior usage.
- 2) Capacities are for selective rack only.
- 3) The above capacities do not consider seismic loading.
- 4) Each column/post of each frame **MUST** be anchored to an adequate concrete floor.
- 5) Capacities based upon installation in a plumb condition.
- 6) Capacities are total per upright, assuming equal loading on both posts. In essence, the listed capacity is the maximum weight that may be stored within one individual rack bay. **DO NOT double the capacity of each upright frame when calculating a single bay's capacity.**
- 7) Capacities are to be reduced to account for the weight of the rack system; deduct the weight of beams, frames, decking, and accessories.
- 8) Your local Building Inspector may require adherence to a specific code, which may reduce the listed capacity. Verify the applicable code and the capacity rating under that code with Steel King or your Steel King Distributor.

If any of these conditions do not apply to your application, or if you are unsure if they apply, DO NOT USE CHART; in those cases, consult Steel King Engineering department for design information.



Changing the configuration (such as adjusting storage levels) can adversely affect the load carrying capacity and reduce the structural integrity of the rack system. Before adjusting the rack configuration, contact Steel King or your Steel King Distributor, to verify the safety and structural adequacy of the new configuration.

Have questions about pallet racks? Answers to Frequently Asked Questions may be found at the following website: www.mhia.org/industrygroups/rmi/faq

If you have any further questions, contact your local Steel King Representative for customer assistance or contact Steel King Industries directly at (800) 826-0203.

WARNING: INSTRUCTIONS FOR ASSEMBLY ARE SET FORTH ON THESE PAGES. PROPER ASSEMBLY IS THE RESPONSIBILITY OF THE PURCHASER AND IS NOT COVERED BY ANY WARRANTY OF THE SELLER. BUYER IS CAUTIONED NOT TO SUBSTITUTE PARTS OR HARDWARE. SELLER DISCLAIMS ALL LIABILITY WITH RESPECT TO ANY SUBSTITUTION OF PARTS OR HARDWARE NOT APPROVED IN WRITING BY SELLER.

THE INSTALLATION DETAIL DRAWINGS THAT FOLLOW ARE INTENDED AS BASIC GUIDES TO INSTALLATION OF THE STANDARD COMPONENTS. DEPENDING UPON THE SPECIFICS OF THE SYSTEM, THERE MAY BE LIMITATIONS REGARDING THE USE OF THESE STANDARD COMPONENTS AND/OR A REQUIREMENT FOR SPECIAL INSTALLATION TECHNIQUES. ADDITIONAL INFORMATION IS FOUND IN STEEL KING PRICE BOOKS, PUBLISHED TECHNICAL DOCUMENTS, COMPREHENSIVE INSTALLATION DRAWINGS, AND OTHER MATERIALS.