

# Standard-Duty Cantilever Rack Installation and Assembly Guide



Steel King Industries, Inc.

2700 Chamber St

Stevens Pont, WI 54481

(800) 826-0203

[www.steelking.com](http://www.steelking.com)

[info@steelking.com](mailto:info@steelking.com)

## ASSEMBLY INSTRUCTIONS:

Steel King Industries recommends that this product be assembled only by qualified personnel, experienced in assembly of storage racks, and knowledgeable of all safety regulations and practices. These instructions are intended only for use by qualified individuals using all proper safety equipment.



These standard-duty cantilever racks are heavy, and if not properly secured during installation and assembly could fall, possibly causing injury or death as well as damage to property.

Contact Steel King Industries or your local Steel King Representative for the name and contact information of a qualified installer. Users of this information agree to indemnify and hold harmless Steel King Industries from any and all liability.

### Step #1: Check the Material

- A. Check to make certain that all materials have been received. Materials should be checked against the packing lists and Bill of Lading.
- B. Notify the shipper immediately of any shortages or product damage.

### Step #2: Check the Area:

- A. Clear the area where the rack system is to be located.
- B. Check the area for all obstructions, such as lights, heating ducts, pipes, building columns, etc., to insure a clear area for the installation of the standard-duty cantilever rack.

**Step #3: Lay Out Floor:****Recommended tools:**

- Tape Measure
- Chalk Line

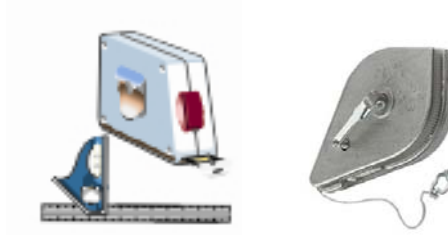

- A. Establish the rack lay out by determining the aisle dimensions and the rack position.

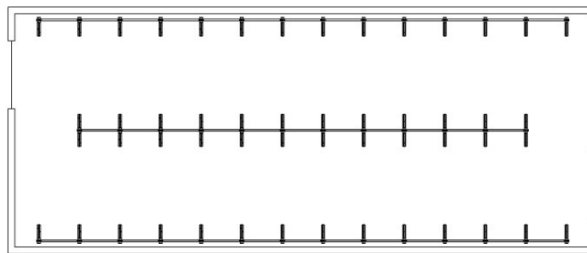

- B. Snap a chalk line establishing the front edge of the upright bases. The chalk line should run the entire length of the row of rack.

**Step #4: Assemble Standard-Duty Cantilever Rack:****Recommended tools:**

- Air compressor,
- Torque wrench,
- 1 1/8" drive impacts or equivalent



- A. Distribute the uprights, bases, arms and bracing for assembly near their final installed position. Use dunnage to protect the floor during this operation.

- B. Mark the arm elevations on the uprights. The marks should be below the top of the arm connector plate so as not to show after the arm is bolted in place.

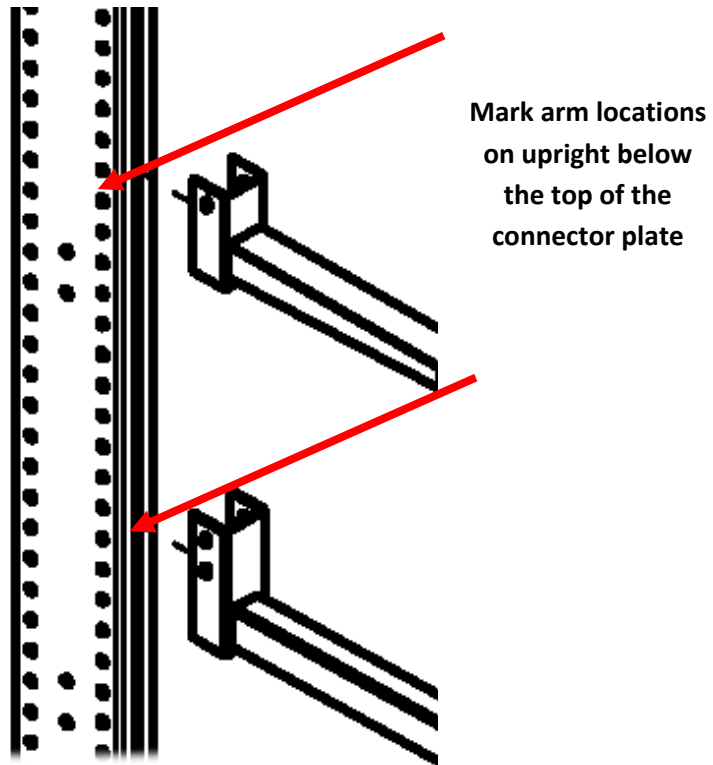

**Step #4: Assemble Standard-Duty Cantilever Rack Continued:**

- C. Bolt the arms to the uprights using the 5/8" diameter x 5 1/2" long grade 5 bolts and nuts. Some arm styles require one (1) bolt connections; others require two (2) bolt connections.

Torque the bolt to 120 ft-lbs.

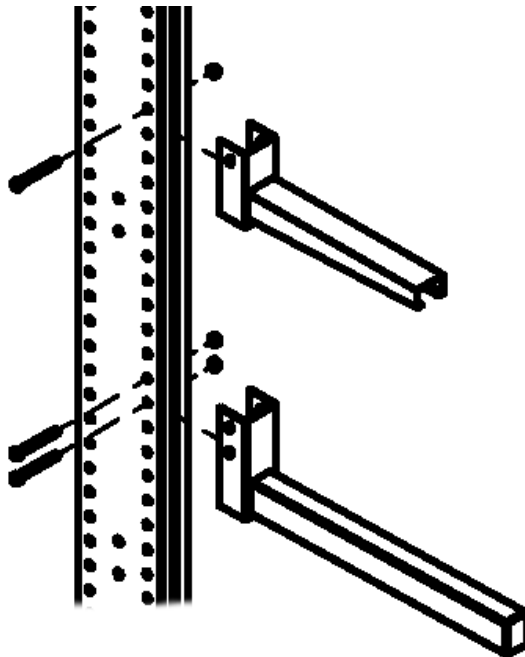
**Step #5: Erect Upright Columns:****Recommended tools:**

- Fork truck or other mechanical lifting device,
- Air compressor,
- Torque wrench,
- 1 1/8" drive impacts or equivalent



- A. Using a fork truck, carefully stand the pre-assembled uprights with arms attached. Please be careful here to protect the floor.
  
- B. Assemble a starter bay. A starter bay includes two preassembled uprights with attached arms and all support bracing
  - Standard-duty cantilever racking with uprights less than 14' require only horizontal braces.
  - Standard-duty cantilever racking with uprights 14' or higher use pre-formed X-braced panels.

### Starter Bay Configurations

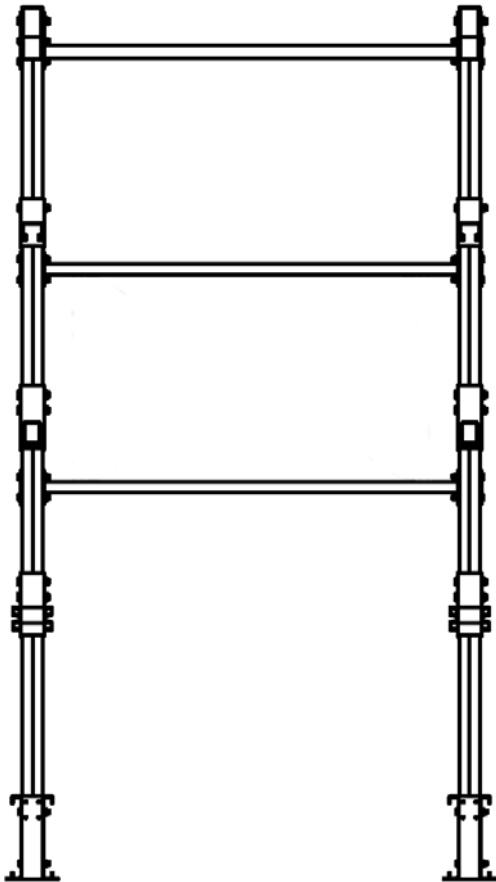

Uprights Less Than 14 Feet High

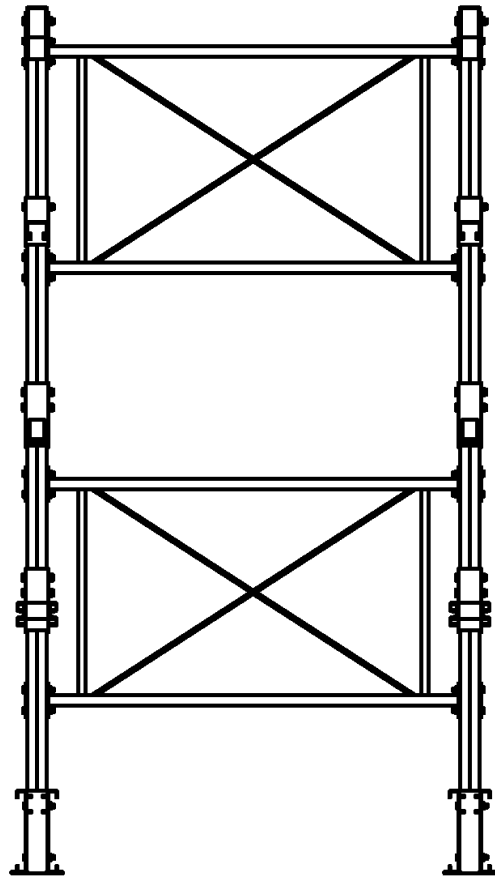

Uprights 14 Feet High or More

---

**Step #5: Erect Upright Columns Continued**

- C. Position and attach horizontal and/or X-panel bracing using 5/8" x 5 1/2" grade 5 bolts and nuts. Horizontal or X-panel bracing requires the use of clips on all outside upright locations.

Tighten all bracing.

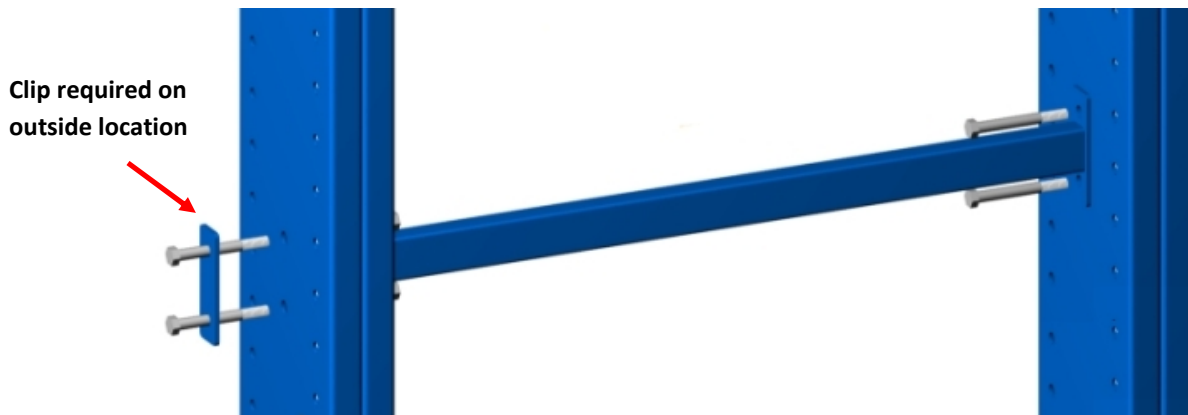

- D. Now the balance of the uprights can be erected to complete the run. The uprights can be stood either one at a time or in groups of 2.

If 2 uprights are to be erected, this should be a bay with the horizontal bracing tightened in place.

**Step #6: Square, Plum, Shim, and Anchor:**

- A. Square, plumb the uprights on the chalk lines.
- B. Shim the uprights and bases to maintain a vertical tolerance of 1/2" or less.

Note: Proper shimming is important because it affects the alignment of the arms.

C. Anchor the uprights and bases using 5/8" x 4-3/4" anchors.

***Proper Anchor Configurations for Single and Double Sided Standard-Duty Cantilever Racks***

**Single Sided, Standard-Duty Cantilever Anchor Configuration – Top View**

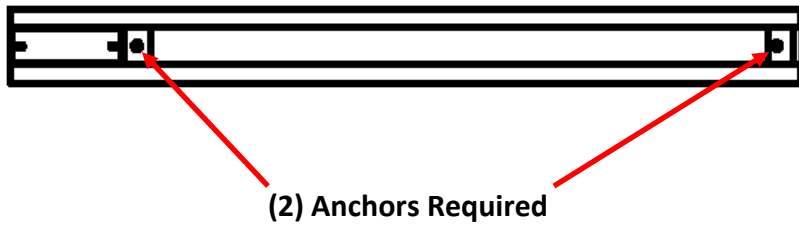

**Double Sided Standard-Duty Cantilever Anchor Configuration – Top View**

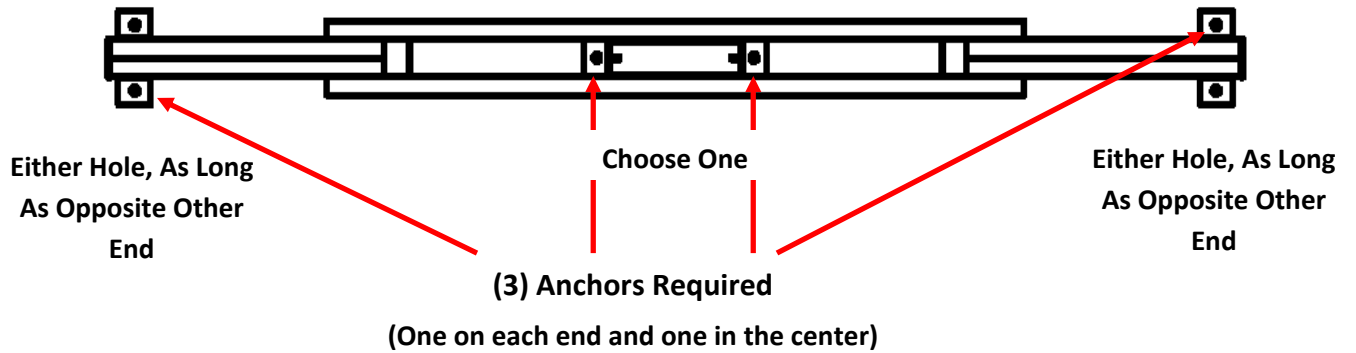

**Step #7: Clean-Up:**



- A. Vacuum all dust and debris associated with setting anchors.
- B. Dispose of all dunnage, strapping and debris. Sweep the floor with a broom if necessary.



**If you have any further questions, contact your local Steel King Representative for customer assistance or contact Steel King Industries directly at (800) 826-0203.**

**WARNING:** INSTRUCTIONS FOR ASSEMBLY ARE SET FORTH ON THESE PAGES. PROPER ASSEMBLY IS THE RESPONSIBILITY OF THE PURCHASER AND IS NOT COVERED BY ANY WARRANTY OF THE SELLER. BUYER IS CAUTIONED NOT TO SUBSTITUTE PARTS OR HARDWARE. SELLER DISCLAIMS ALL LIABILITY WITH RESPECT TO ANY SUBSTITUTION OF PARTS OR HARDWARE NOT APPROVED IN WRITING BY SELLER.

THE INSTALLATION DETAIL DRAWINGS THAT FOLLOW ARE INTENDED AS BASIC GUIDES TO INSTALLATION OF THE STANDARD COMPONENTS. DEPENDING UPON THE SPECIFICS OF THE SYSTEM, THERE MAY BE LIMITATIONS REGARDING THE USE OF THESE STANDARD COMPONENTS AND/OR A REQUIREMENT FOR SPECIAL INSTALLATION TECHNIQUES. ADDITIONAL INFORMATION IS FOUND IN STEEL KING PRICE BOOKS, PUBLISHED TECHNICAL DOCUMENTS, COMPREHENSIVE INSTALLATION DRAWINGS, AND OTHER MATERIALS.