

REV.	DWG #:	REV.	ECR #	DATE	REVISIONS	INITIAL
	33-126-002					

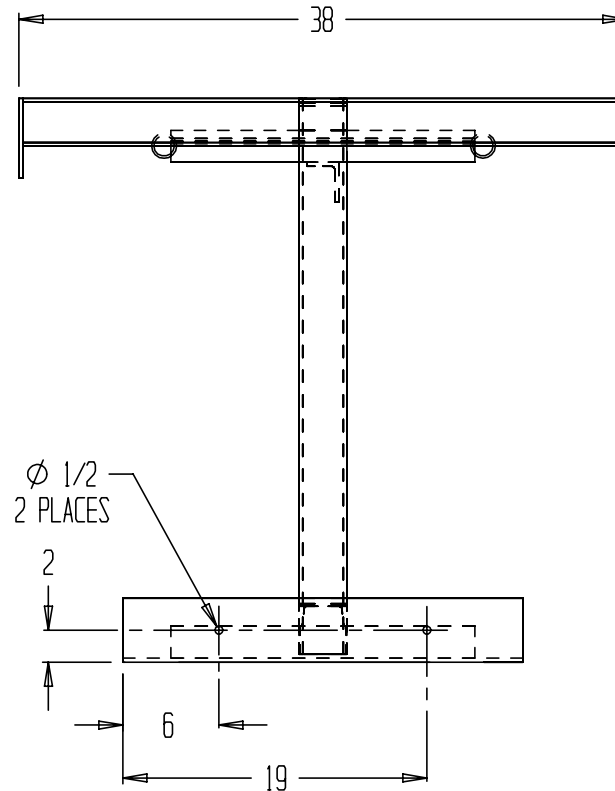
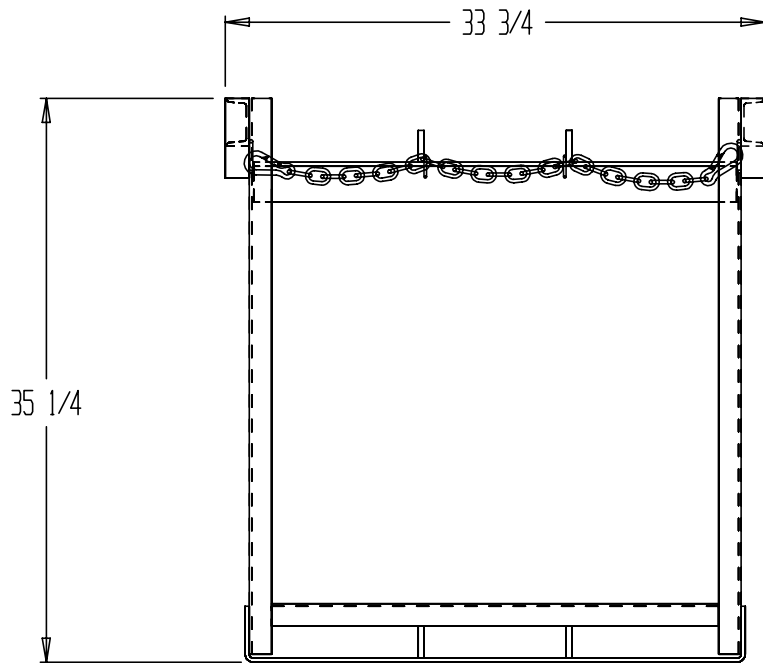

THIS PRINT IS CONFIDENTIAL AND IS THE PROPERTY OF
T & S EQUIPMENT CO.
 THIS PRINT SHALL NOT BE USED, COPIED OR REPRODUCED IN WHOLE OR IN PART NOR SHALL THE CONTENTS BE REVEALED IN ANY MANNER TO ANYONE UNLESS WRITTEN PERMISSION IS OBTAINED FROM
 T & S EQUIPMENT CO.

REMOVE ALL BURRS AND SHARP EDGES		
CONCENTRIC	.006 TIR	.060 TIR
ANGLES	+/- 0° 30'	+/- 1° 0'
DECIMALS	x.xxx +/- .005 x.xx +/- .010 x.x +/- .025	+/- .015
FRACTIONS	+/- 1/32	+/- 1/16
TOLERANCE	MACHINE	WELDMENT

T & S EQUIPMENT COMPANY			
INSTRUCTIONS, CASTER OPTION (HOLE LOCATIONS) CYL-190			
DRAWN BY: T.NEIJENSCH	SCALE: 1 : 12	CHK'D:	
MATERIAL:	DATE: 5-17-00	DRAWING NO:	REV:
	APP'D:	33-126-002	