

RiveTier® I

Assembly Instructions RiveTier 1 Record Archive Shelving

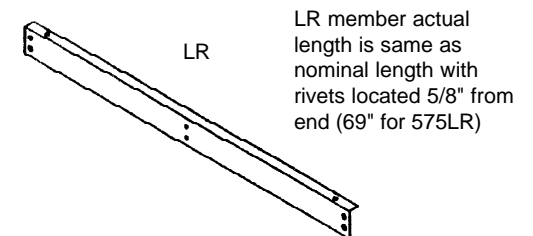
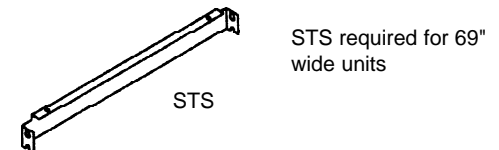
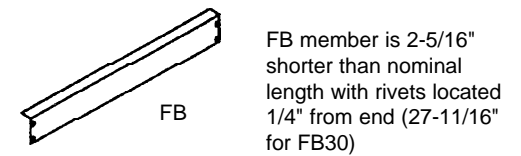
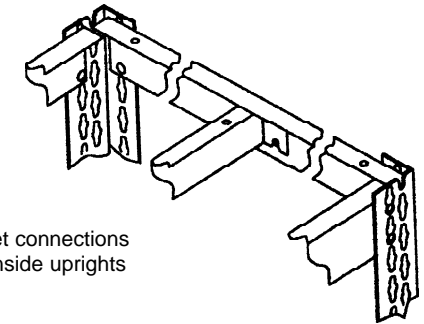
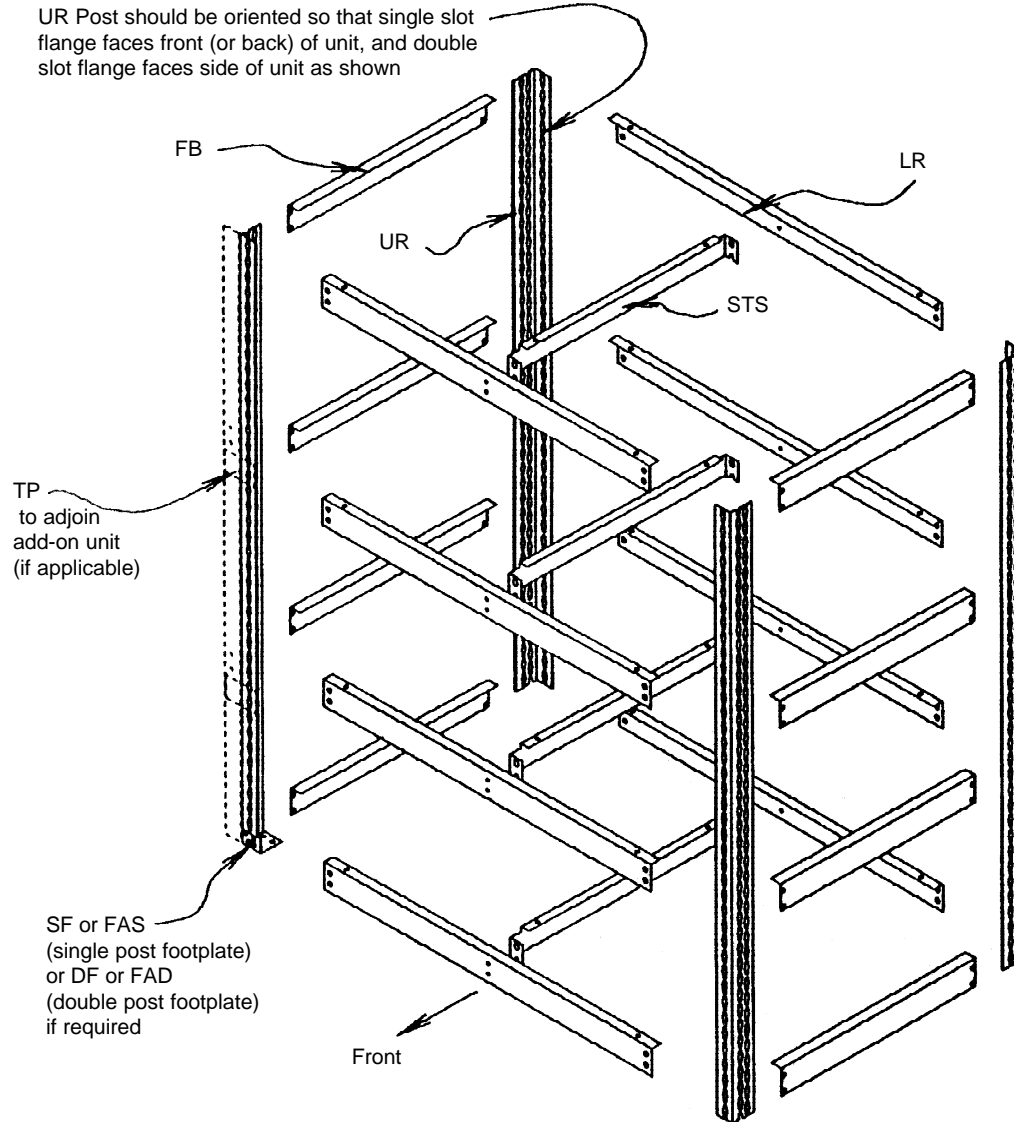

NOTES

- Particle board not shown for clarity. For ease of installation, shorter depth units should be assembled from the bottom up, inserting particle board as each shelf level is assembled.
- Rivets on beams insert into key slots on posts. Beam must be hit firmly with mallet to seat rivets properly.
- Bottom beam level to be 3" max. from ground level.