

# Open Unit Assembly

- 1 Lay two Angle posts on floor or saw horses with 1" flange down. Bolt the top shelf to the sides of the posts in the top round hole (**Fig. 1**). Bolt the bottom shelf the same way using the third hole from the bottom of the post, or location where the bottom shelf will be required (3" max. from floor). Place right and left Angle, Beaded or Delta posts at front post locations as shown in (**Fig. 1**), then bolt from the sides. For 18-gauge shelves and non-seismic applications, clips may be used instead of bolts on top and bottom shelves. With top and bottom shelves bolted or clipped securely, stand the unit upright.
- 2 Install intermediate shelves using four clips per shelf. Shelves are adjustable on 1 1/2" centers using the square cutouts on the posts for clip attachment.
- 3 Attach the back sway brace (longer than the side sway braces) to the outside of the posts approximately 1/3 of the way between the top and bottom shelves (**Fig. 2**). Back to back units share a common sway brace.
- 4 Attach the side sway braces to the sides of the unit approximately 1/3 of the way between the top and bottom shelves (**Fig. 2**). For Beaded and Delta front posts, the side sway brace is placed between post flanges. When two or more units are bolted together side by side, the side sway brace is common between units. If installing Beaded or Delta post units, the Beaded or Delta post is common between units. Bolt centers of sway braces together.
- 5 Additional shelving units may be added to form a row by placing the side sway brace between 2 Angle posts, then proceeding to attach the adder unit(s) to the starter unit. If the bottom shelf must be less than 3" from floor to the bottom of shelf, then the top and bottom shelves should be attached while shelving unit is on its back (**Fig. 1**). For Beaded or Delta post adder units with the bottom shelf less than 3" from the floor, the top and bottom shelves must be attached (bolted) to the entire row before standing units upright.

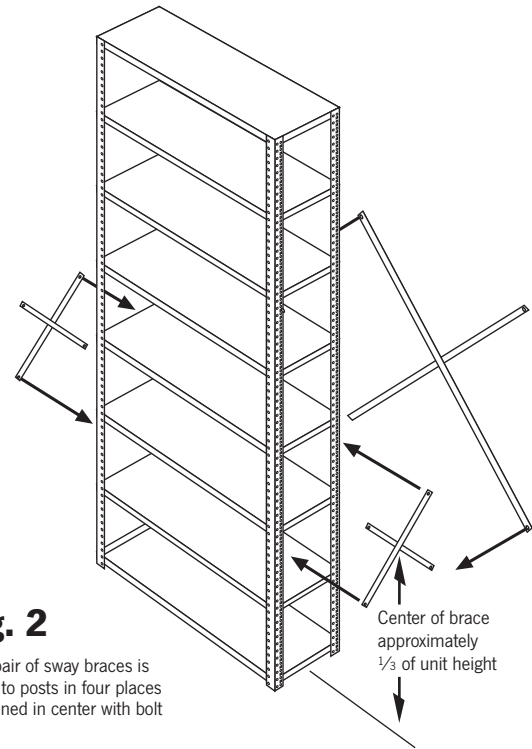

**Fig. 2**

Each pair of sway braces is bolted to posts in four places and joined in center with bolt

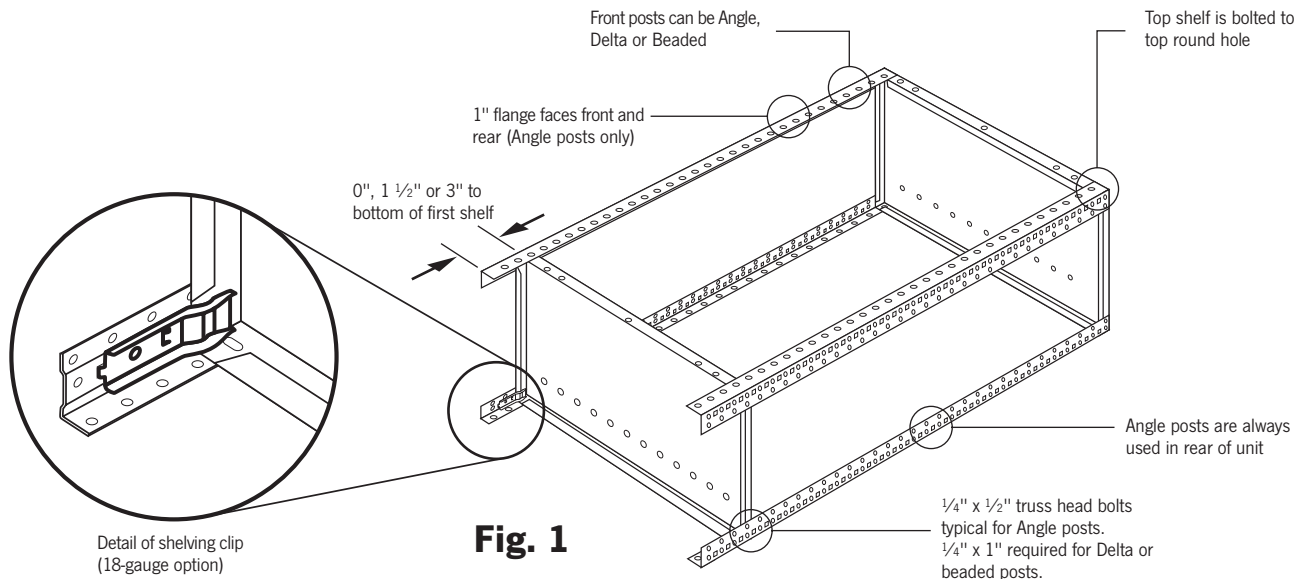

**Fig. 1**

Detail of shelving clip  
(18-gauge option)