

EdgeAlert™ Open Gate Alarm Kit

No. SG3060, SG3060-SL, SG3060-TL



Patent Pending

Contents

Description of Operation.....	1
Circuit Board Configuration.....	2
Installation Instructions.....	3
Maintenance, General Specifications.....	7
Warranty.....	8

Features and Benefits

- ✓ EdgeAlert™ Alarm senses for an open gate condition.
- ✓ Amber LED lights on the front and back alert personnel on the elevated surface and below.
- ✓ A horn sounds with LED lights and has (3) loudness levels.
- ✓ Snooze feature will silence the horn for 2 minutes.
- ✓ Sensors have dual channels for redundancy.
- ✓ Circuit board incorporates dual microprocessors.
- ✓ Sensor condition is monitored.
- ✓ Battery or plug-in AC power supply.
- ✓ Low battery chirp alert is included.
- ✓ Additional signal devices can be connected to the output relay.
- ✓ Quality Wildeck® EdgeAlert™ Open Gate Alarm is manufactured in the USA and provides a long service life.

Description of Operation

The device senses for an open gate condition, by the use of a two piece sensor (sensor and magnet). The sensor turns off when it is separated by approximately 7/8" from the magnet. When the sensor turns off, then the alarm becomes active. The alarm is indicated by flashing amber lights and a horn. The Snooze / Acknowledge button will silence the horn for two minutes. After the gate is closed and latched, press Snooze / Acknowledge, when in the "confirm reset mode". Pressing Snooze / Acknowledge is not required in "auto reset mode".



A low battery is announced with a single chirp alert and a slow flashing red fault light. Controller or sensor fault condition is indicated by a double chirp alert and a double flashing red fault light and amber lights. Do not use gate in low battery or fault condition. **Do not use gate if alarm fails to sound horn or flash amber lights with an open gate condition.**

Summary of Operation

Condition	Horn	Amber Lights	Red Fault Light	Relay Output
Open Gate	<i>Beep</i> <i>1 Sec On / Off</i>	<i>Flash</i> <i>1 Sec On / Off</i>		<i>On</i>
Open Gate, in Snooze		<i>Flash</i>		<i>On</i>
Low Battery*	<i>Slow Chirp</i>		<i>Slow Flash</i>	<i>Off</i>
Fault*	<i>Double Chirp</i>	<i>Double Flash</i>	<i>Double Flash</i>	<i>On</i>

*Do not use gate.

Circuit Board Configuration

Configure the circuit board for your application, by moving jumpers on the circuit board. Below the module is shown with the cover removed.

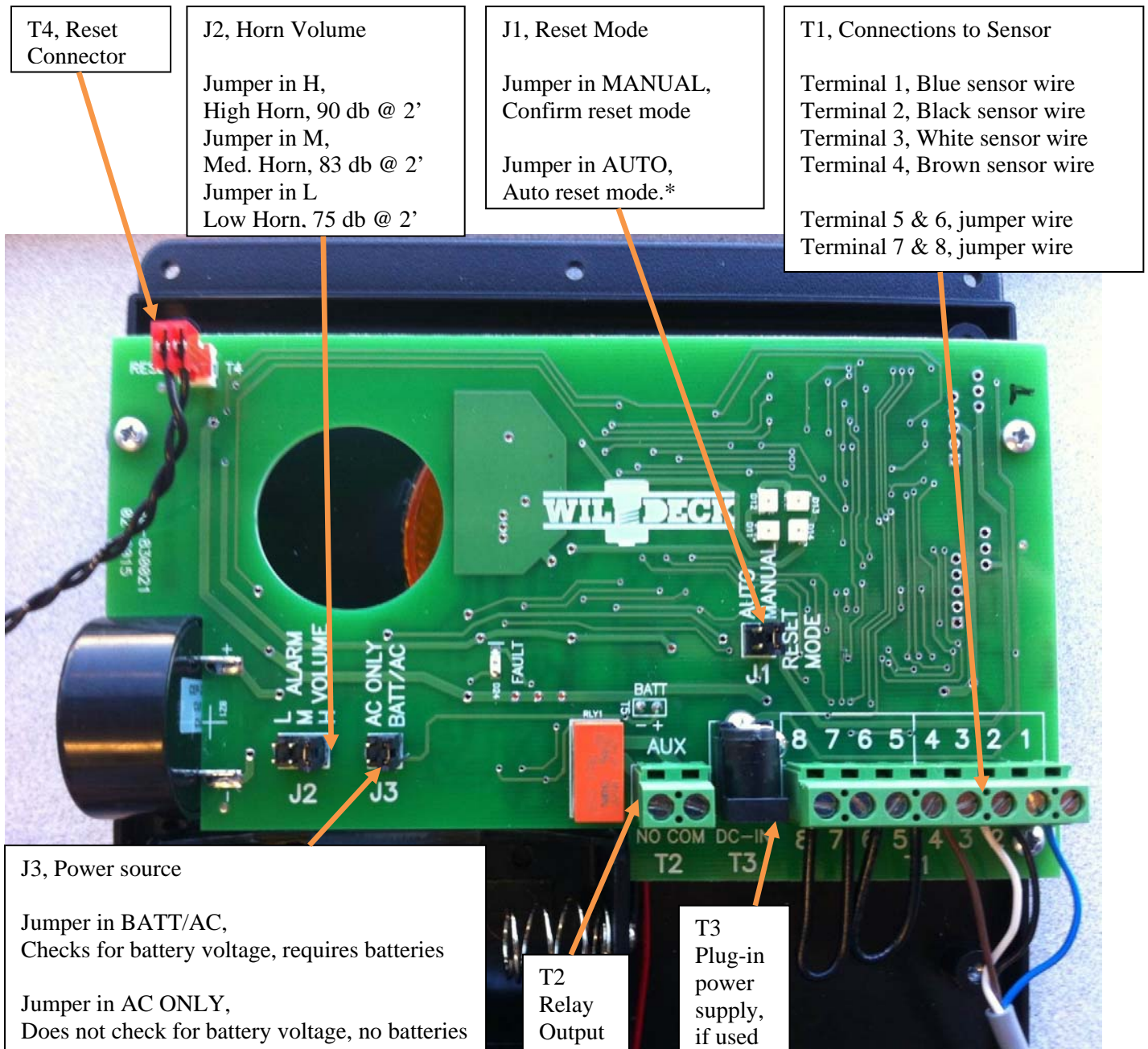

*Note: Only use Auto Reset mode if your gate locks automatically every time the gate is closed.

Installation Instructions

- 1) Find your gate type beginning on sheet 5.
- 2) Place the gate in the locked closed position.
- 3) Attach (2) rail plastic sleeve inserts over 1 1/2" OD pipe for the module bracket. Attach a rail plastic sleeve insert over 1 1/2" OD pipe for the sensor bracket. The rail plastic sleeve may be cut with sheet metal snips to slip the sleeves over the pipes. The sleeves are not used for 1 5/8" OD rail pipe.

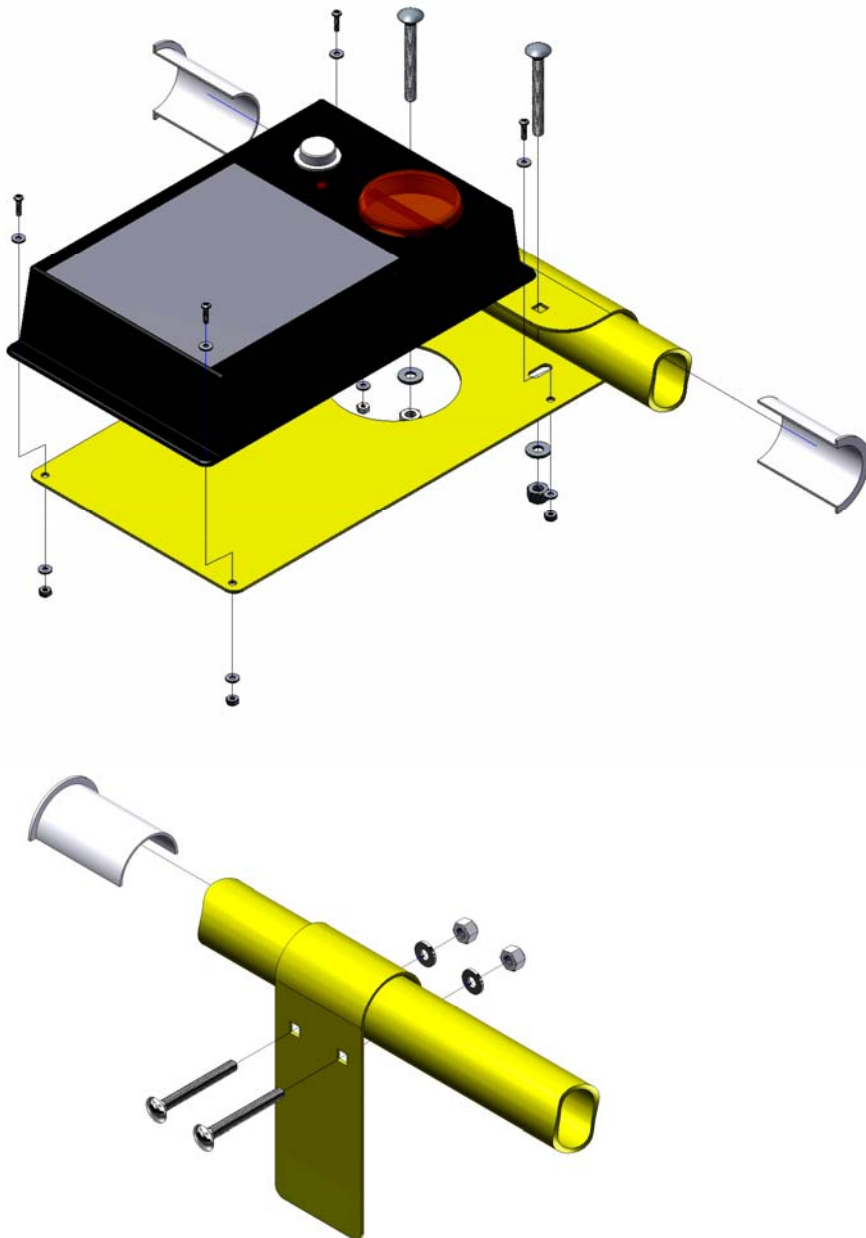

- 4) Attach the brackets with included 1/4" carriage bolts and hardware.
- 5) Attach the module onto the bracket with number four machine screws, at the corners.

- 6) Sensor and magnet have self-adhesive backing. Clean and dry the areas where the sensor and magnet will be attached. Position the sensor and the magnet with a 7/16" air gap between the parts. Note how the arrows in the middle of the sensor and magnet must line up. Press and hold the sensor and magnet for one minute after removing the backing paper.

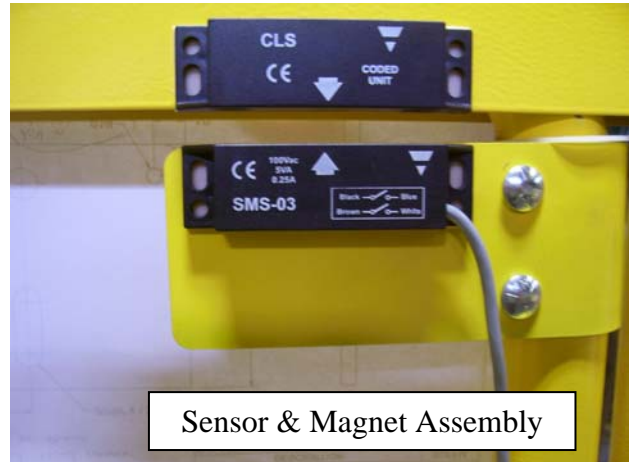

- 7) Route the cable from the sensor to the module and secure with cable ties.
- 8) Remove the six stainless steel screws from the cover of the module. Support the cover or disconnect the Snooze / Acknowledge two-wire connector on the circuit board marked RESET, T4.
- 9) Connect the sensor to the module. Secure extra cable for sensor by coiling up unused cord in the lower right hand corner of the module. Place cable tie on sensor cord, just inside the module to act as a cord stop.
- 10) Connect external circuit alarm relay marked T2, if used.
- 11) Set the circuit board configuration for your application, see sheet 2.
- 12) The horn may sound and the lights may flash (alarm mode) when the batteries are installed. Load (4) D cell batteries, type: IEC LR20, Duracell Mn1300, Energizer EN95 or Rayovac 813.
- 13) Plug external power supply plug into socket marked T3, if used. Adjust jumper J3.
- 14) Route all cords to the bottom right hand side of the enclosure.
- 15) Reconnect the Snooze / Acknowledge two-wire connector on the circuit board marked RESET, T4, if removed.
- 16) Attach cover and tighten the six stainless steel screws.
- 17) Attach warning label, SG3025 to front surface of gate, see SG3060 drawing on sheet five.
- 18) Test the installed unit for proper operation. Open the gate. The alarm must turn on by flashing amber lights and sounding the horn.

Unit shall turn on the alarm when sensor separates by approximately 7/8" from the magnet. The Snooze / Acknowledge button will silence the horn for two minutes. After gate is closed and latched, then press Snooze / Acknowledge (when in the "confirm reset mode") and the alarm will be silenced.

Gate Figure 1: Swing Gate

BILL OF MATERIALS			
ITEM	QTY	DESCRIPTION	PART #
1	1	Module, Device	SG3040
2	1	Label, Front of Device	SG3030
3	1	Label, Warning	SG3025
4	1	Sensor, Magnetic, w/ 2m cable	SG3005
5	1	Magnet, Multiple Flux Coding	SG3000
6	1	Bracket, Device Mount	SG3015Y
7	1	Bracket, Sensor Mount	SG3020Y
8	1	Hardware Package	SG3050
9	1	Very High Bond Tape	SG3035
10	1	AC adaptor, 6VDC, 2.1mm plug	SG3010
11	1	Manual	SG3045

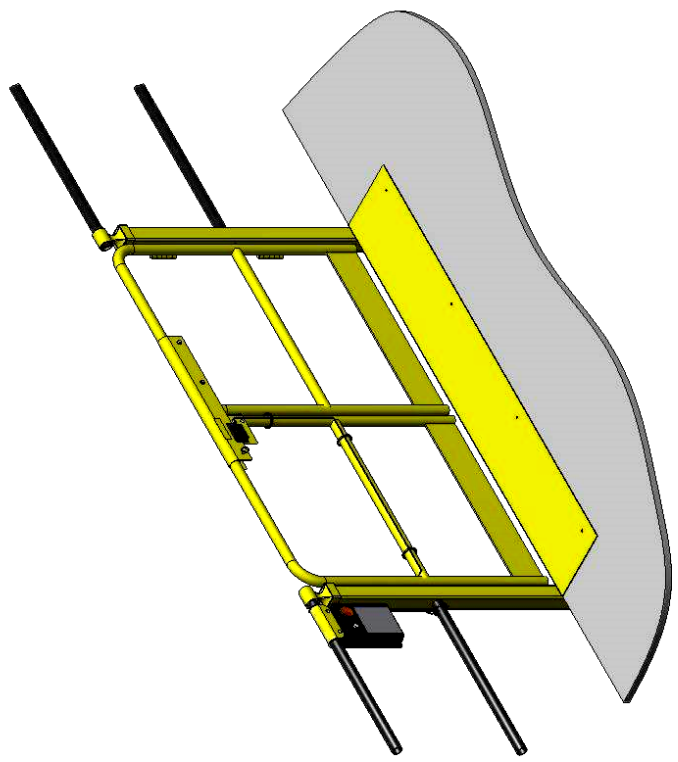
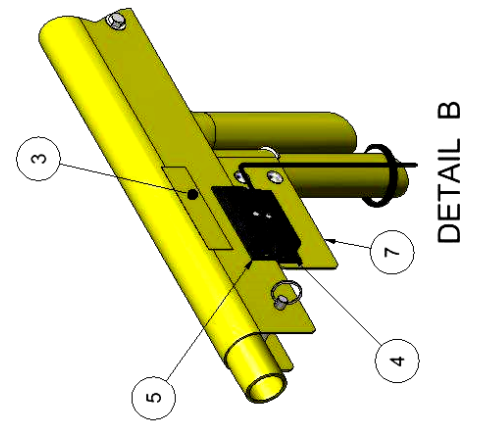
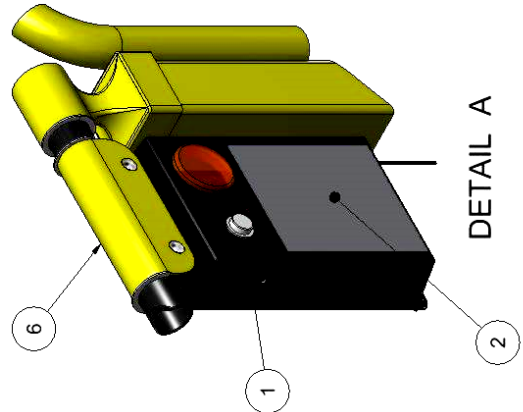
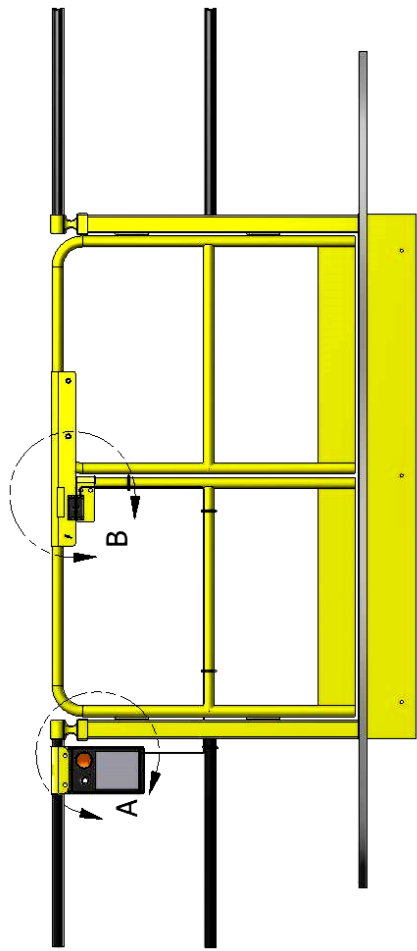

DRAWN BY: AGR
 DATE: 1/27/2015
 REV. 1
 DATE:

EdgeAlert Alarm Assembly



JOB #:
 QTY:

SG3060

Gate Figure 2: Slide Gate

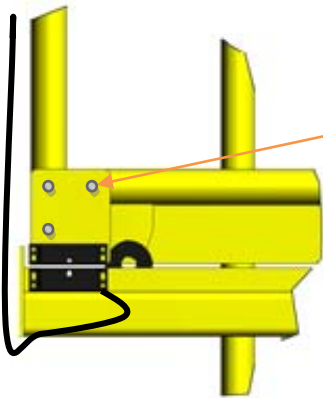
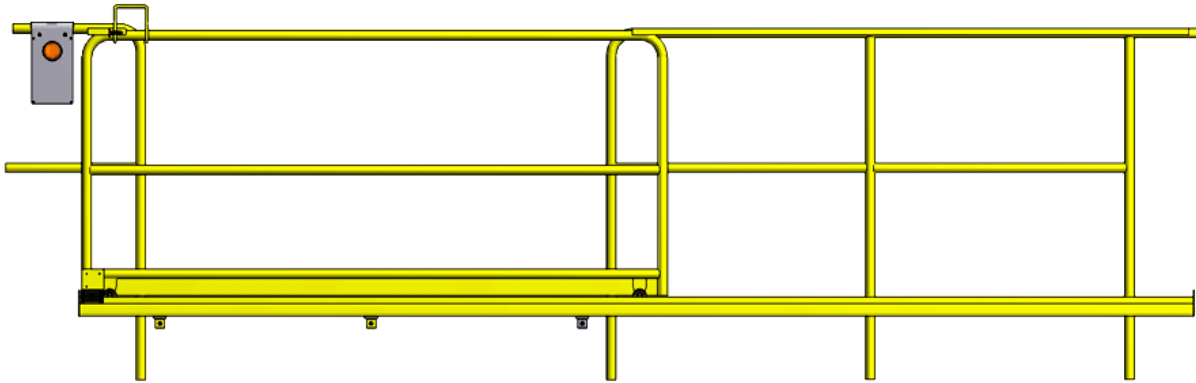

Attach SG3055 with Tek screws. Attach sensor and magnet with adhesive backing onto clean surfaces.
7/16" Gap between sensor & magnet
Flush +/- 1/4"

Gate Figure 3: Tilt Gate

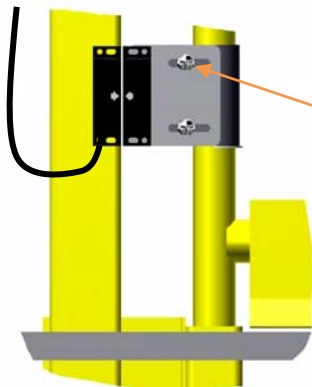

Attach SG3065 & SG3070 with 1/4" hardware. Attach sensor and magnet with adhesive backing onto clean surfaces.
7/16" Gap between sensor & magnet
Flush +/- 1/4"

Gate Figure 4: Lift-Out Gate

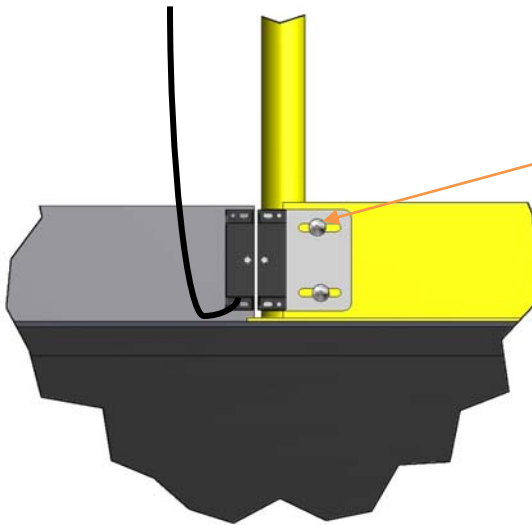

Attach (2) SG3065 with 1/4" hardware, field drill. Cut carriage bolts to 3/4" long, with hacksaw. Attach sensor and magnet with adhesive backing onto clean surfaces. 7/16" Gap between sensor & magnet
Flush +/- 1/4"

Maintenance

Daily

- ▶ Check for the correct operation of the unit.

Every 6 Months

- ▶ Check for the correct operation of the unit.
- ▶ Check for corrosion of any batteries. Replace if needed.
- ▶ Inspect the device for wear, abuse or modification to the unit.
Unit has no serviceable parts. Should the unit malfunction or is damaged, then replace unit.

General Specifications

Category	Specification
Environment	Designed for an indoor installation
Atmosphere	No corrosive or volatile liquids, vapors, gas or dust
Operating Temperature	35°F to 122°F
Altitude	Altitudes below 10,000 feet
Relative Humidity	Relative Humidity 5 to 95% noncondensing
Batteries (not included)	Quantity (4), D Cell, Type: IEC LR20, Duracell Mn1300, Energizer EN95 or Rayovac 813
Wall Plug-in Power Supply	Input Voltage rating: 100-240 VAC, 50/60 Hz, 0.2 Amp Max
Alarm Relay Contacts	N.O. Rated at 2 amperes resistive load at 30 VDC
Horn	75-90 db at 2 feet, (3 loudness settings)
Module, Environment	NEMA Type 1
Sensor, Environment	IP 67
Weight, Module	1.5 lbs
Overall Size	6 3/8" W x 10 1/2" H x 3" D
Mounting Type	Bolt-on, Round pipe, 1 1/2" OD or 1 5/8" OD

Bill of Material SG3060, EdgeAlert Kit, Swing Gate

Part No.	Description	Quantity
SG3040	Module, device	1
SG3030	Label, front of device, installed	1
SG3025	Label, warning, gate, 1 1/2" x 5"	1
SG3005	Sensor, magnetic, w/ 2m cable	1
SG3000	Magnet, multiple flux coding	1
SG3015Y	Bracket, device mount	1
SG3020Y	Bracket, sensor mount	1
SG3050	Hardware package	1
SG3035	Very high bond tape, installed	(2) Each 3 7/16" Lg.
SG3010	Power supply, AC	1
SG3045	Manual	1

Bill of Material SG3060-SL, EdgeAlert Kit, Slide Gate

Less SG3020Y but adds the following parts:

SG3055Y	Bracket, sensor mount flat	1
HWST1224X0875TEK	Screw, TEKS 5 12-24 x 7/8"	4

Bill of Material SG3060-TL, EdgeAlert Kit, Tilt / Lift Gate

Less SG3020Y but adds the following parts:

SG3065Y	Sensor adjustment bracket	2
SG3070Y	Bracket, Tilt/Lift Gate	1

WARRANTY

Wildeck products are warranted to be free of material defects and workmanship for a period of one (1) year.

The warranty begins at time of shipment from Wildeck's factory. Labor to install, adjust, maintain or replace the warranted unit, or any component part, is not included.

This warranty is valid only if the product has been installed in complete accordance with Wildeck's Installation Instructions. Improprieties including but not limited to abuse, negligence, or failure to install, maintain or adjust the equipment properly, will void the warranty.

The warranty is also voided if unauthorized parts, hardware or equipment are installed, or modifications are made to the product without prior written authorization. Wildeck reserves the right to change, at any time, the material, design or specifications of its products without obligation to subsequent purchases, or add improvements without making corresponding changes to products previously manufactured.

WILDECK SHALL NOT IN ANY EVENT BE LIABLE FOR ANY DAMAGES, WHETHER BASED ON CONTRACT, WARRANTY, NEGLIGENCE, STRICT LIABILITY OR OTHERWISE, INCLUDING WITHOUT LIMITATION ANY CONSEQUENTIAL, INCIDENTAL OR SPECIAL DAMAGES, ARISING WITH RESPECT TO THE EQUIPMENT OR ITS FAILURE TO OPERATE, EVEN IF WILDECK HAS BEEN ADVISED OF THE POSSIBILITY THEREOF.

WILDECK MAKES NO OTHER WARRANTY OR REPRESENTATION OF ANY KIND, EXCEPT THAT OF TITLE, AND ALL OTHER WARRANTIES, EXPRESSED OR IMPLIED, INCLUDING WARRANTIES OR MERCHANTABILITY AND FITNESS FOR A PARTICULAR PURPOSE, ARE HEREBY EXPRESSLY DISCLAIMED.



P.O. Box 89 • 405 Commerce Street
 Waukesha, WI USA 53186
 262-549-4000 • 800-325-6939
 FAX 262-549-3466 • info@wildeck.com
www.wildeck.com