

SAFETY-VIEW PLUS K. D. 4-WIDE WALL MOUNT STOCK LOCKER ASSEMBLY INSTRUCTIONS

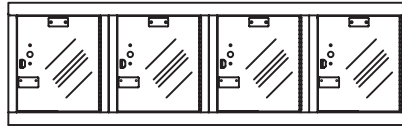

General Instructions

1. Check material received against the packing list. First check the number of packages received and then check the contents of each package.
2. Check material received for damage. If damage has occurred, secure a "damage notation" from the carrier.
3. Identify each part as it is unpacked and put like parts together as close as possible to the working area in which they are to be assembled.
4. Be careful to use the correct hardware as specified in the assembly instructions.
5. Items with suffix (xx) are available options.

CAUTION

IN THE INTEREST OF SAFETY, ALL LOCKERS MUST BE SECURELY ANCHORED TO THE FLOOR AND/OR WALL.
FOR SAFETY, HANDLE ALL COMPONENTS CAREFULLY AND WEAR WORK-GLOVES WHEN ASSEMBLING LOCKERS.
INSTALL ALL UNITS PLUMB AND TIGHTEN ALL HARDWARE SECURELY.
RETAIN INSTRUCTIONS FOR FUTURE REFERENCE.



2823 W. Orange Ave. Apopka, FL 32703

Ph: (866) 566-0500

Fx: (407) 464-3610

www.Hallowell-List.com

SAFETY-VIEW PLUS K. D. 4-WIDE WALL MOUNT STOCK LOCKER ASSEMBLY INSTRUCTIONS

PACKAGE CONTENTS

REF. NO.	DESCRIPTION	PART NO.	QTY.
①	DOOR FRAME ASSEMBLY	LKDF4812-16SVP	1
②	CENTER REAR PANEL	KR16CP	1
③	CENTER BOTTOM	KP16CB18	1
④	CENTER TOP	KP16CT18	1
⑤	CENTER SIDE PANEL	KP16CS18	3
⑥	WALL MOUNT END PANEL	WMEP18	2
⑦	BOX DOOR LATCH PULL	KBLP100	4
⑧	NUMBER PLATE	NPL100	4
⑨	NUMBER PLATE RIVET	RV101	8
xx⑩	STRIKE PLATE	xxSP100	xx4
⑫	3/8" SLOTLESS BOLT	MBT200	58
⑬	HEX NUT	N201	50
⑭	HI-DOME CAP NUT	N110	8
x⑮	PIANO HINGE	PH11	4
x⑯	DOOR	LKD1272-6SVP	4
x⑰	RIVET (HINGE)	RV102	8

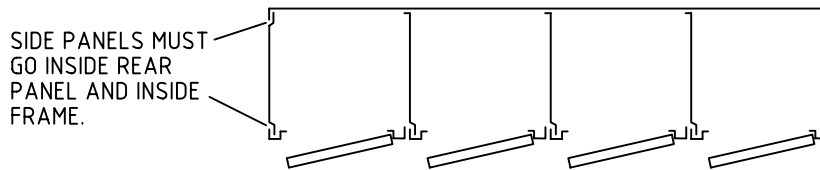
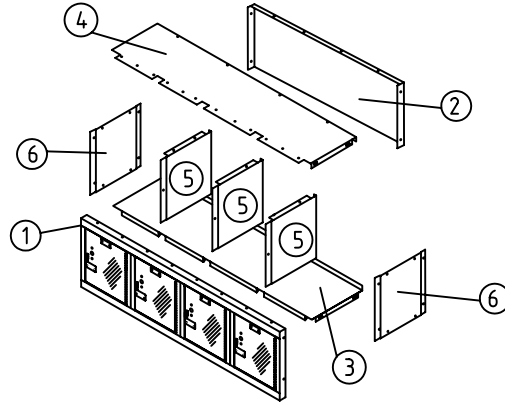

TOP VIEW OF 4-WIDE WALL MOUNT

HALLOWELL MAKES EVERY EFFORT TO ENSURE THAT ALL UNITS SHIP COMPLETE. HOWEVER, SHOULD YOUR UNIT CONTAIN MISSING OR DAMAGED PARTS, REPLACEMENTS MAY BE OBTAINED FROM HALLOWELL. TO OBTAIN PARTS, FOLLOW THESE INSTRUCTIONS.

PLEASE PROVIDE THE FOLLOW INFORMATION:

MODEL NUMBER	PURCHASE DATE
DESCRIPTION OF PART(S) NEEDED & PART NUMBER(S) AS SHOWN IN PARTS LIST	COMPANY NAME & CONTACT PERSON
COLOR	WHERE THE PRODUCT WAS PURCHASED FROM

IF REQUESTING PARTS BY TELEPHONE, ASK FOR CUSTOMER SERVICE & PROVIDE THE ABOVE INFORMATION.

NOTE:

x SHIPS PRE-HUNG IN FRAME ASSEMBLY. xx STRIKE PLATES ARE OPTIONAL - INCLUDES TWO RIVETS (9).

TWO-YEAR WARRANTY

HALLOWELL KD LOCKERS ARE COVERED AGAINST ALL DEFECTS IN MATERIALS AND WORKMANSHIP EXCLUDING FINISH, DAMAGE RESULTING FROM DELIBERATE DESTRUCTION AND VANDALISM FOR A PERIOD OF TWO YEARS.



SAFETY-VIEW PLUS K.D. 4-WIDE WALL MOUNT STOCK LOCKER ASSEMBLY INSTRUCTIONS

STEP 1

BOLT KP16CT (4) CENTER TOP TO KP16CS (5) CENTER PANEL.

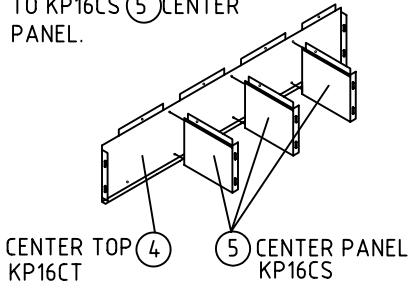

STEP 3

BOLT KP16CB (3) CENTER BOTTOM TO (2) CENTER REAR AND (5) CENTER PANEL

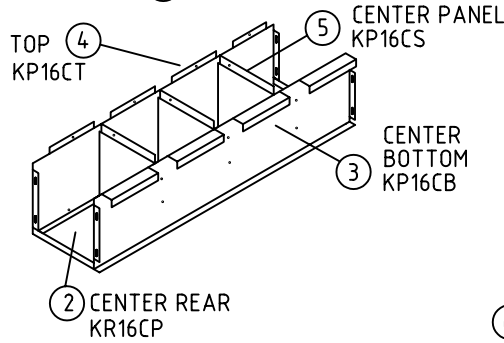

STEP 5

WITH REAR OF 4-WIDE UNIT ON A FLAT SURFACE, BOLT WMEP18 (6) TO RIGHT AND LEFT SIDES USING BOLTS (12) THRU HOLES.

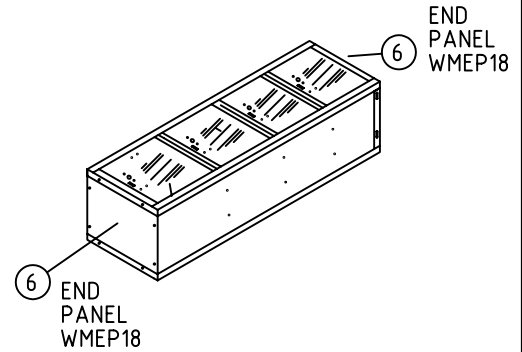

STEP 2

BOLT (4) TOP AND (5) CENTER PANEL TO KR16CP (2) CENTER REAR PANEL

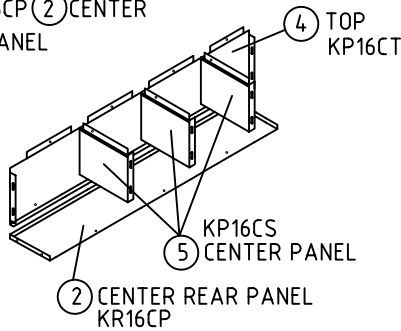

STEP 4

BOLT KDF4812-16SVP (1) DOOR FRAME ASSEMBLY TO 4-WIDE UNIT

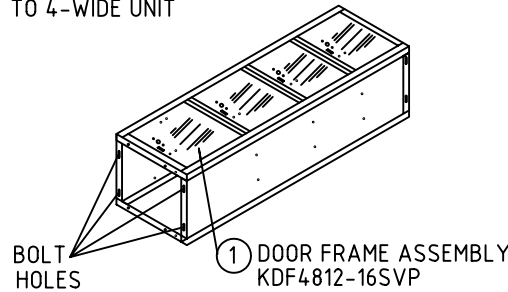

STEP 9

STAND LOCKER UPRIGHT AND MOUNT TO WALL AFTER STEPS 7 AND 8.

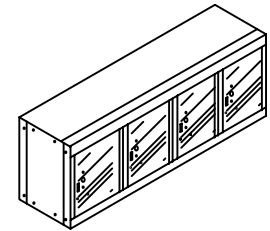

STEP 7

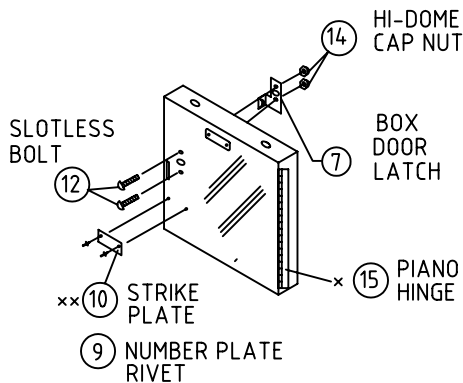

ASSEMBLY OF STRIKE PLATE & LATCH PULL

STEP 8

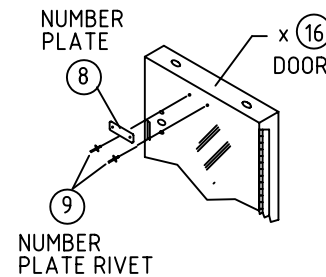

ASSEMBLY OF NUMBER PLATE

HARDWARE USED FOR MAIN LOCKER ASSEMBLY



10 - 24 x 3/8"



N202 HEX NUT (13)

MBT200 SLOTLESS BOLT (12)

TIGHTEN NUT WITH A NUT DRIVER OR WRENCH (SCREW IS TAMPER RESISTANT).



TOOLS REQUIRED: 3/8" NUT DRIVER (3/8" SOCKET MAY BE SUBSTITUTED)



2823 W. Orange Ave. Apopka, FL 32703

Ph: (866) 566-0500

Fx: (407) 464-3610

www.Hallowell-List.com