

# Model 190-LRC Live Roller Curve Conveyor

The Model 190-LRC is a medium-duty live roller curve that provides a positive drive for negotiating 30°, 45°, 60°, or 90° turns. It may be self-powered or can be slave driven from 190-ACC, LRS or LRSS conveyors.



- ★ 12 Bed Widths
- ★ Reversible
- ★ Tapered Tread Rollers
- ★ Adjustable MS-Type Floor Supports Available

Between Rail Width	Overall Frame Width	"R"	Total Number of Rollers*				WEIGHTS (Lbs.)			
			90°	60°	45°	30°	90°	60°	45°	30°
13"	16"	24"	16T/4S	10T/12S	8T/12S	5T/12S	336	330	323	317
15"	18"						349	343	336	300
17"	20"	32 1/2"	20T/4S	14T/12S	10T/12S	7T/12S	364	357	350	343
19"	22"						378	371	364	357
21"	24"						393	386	378	371
23"	26"						408	401	393	386
25"	28"						425	417	409	401
27"	30"						442	434	425	417
31"	34"	48"	30T/4S	22T/12S	14T/12S	10T/12S	562	551	540	529
33"	36"						585	573	562	550
37"	40"						625	613	601	589
39"	42"						651	638	625	612

\*T = TAPERED  
S = STRAIGHT

All weights in catalog are conveyor weights only. Accessories, crating, etc., are not included.

ACCUMULATION - MINIMUM PRESSURE

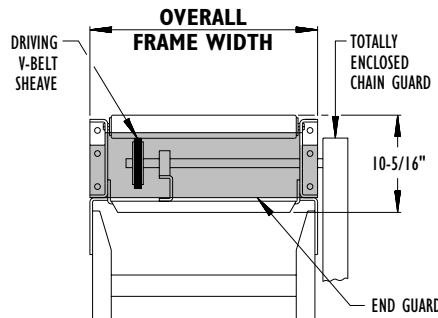
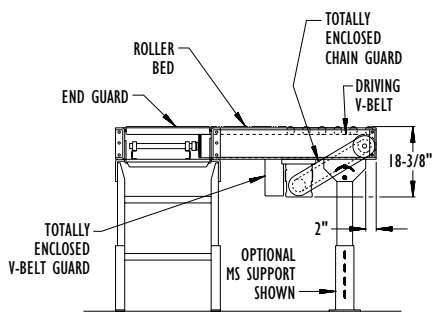

VIEW "X-X"

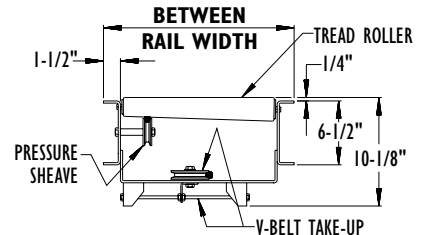

VIEW "Y-Y"

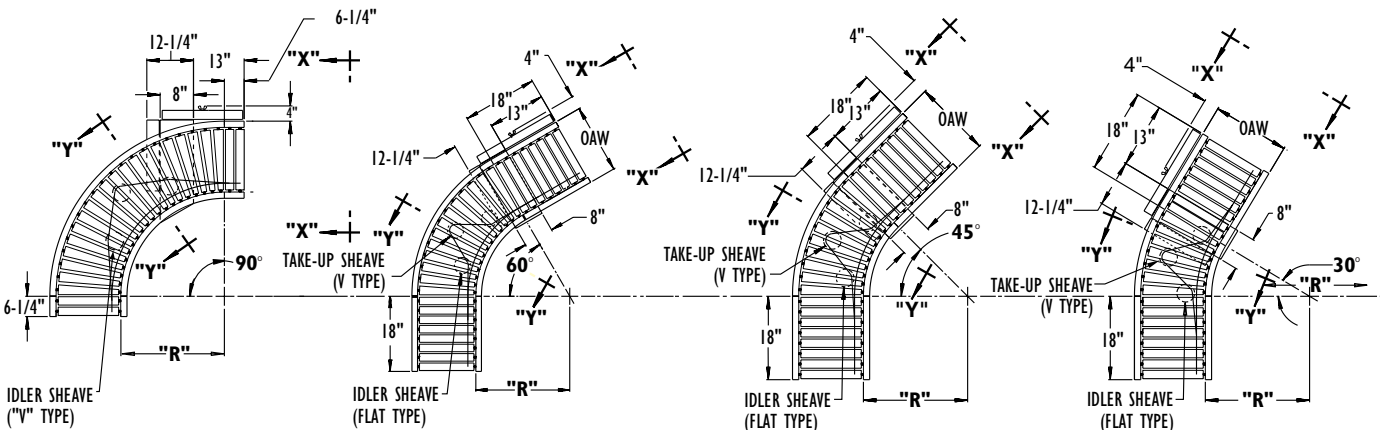

## Standard Specifications

**BED**—Roller bed with 2-1/2 in. dia. tapered to 1-11/16 in. dia. x 16 ga. galvanized and 1.9 in. dia. roller x 16 ga. galvanized tube. Mounted in 6-1/2 in. x 12 ga. powder painted formed steel channel frame.

**END DRIVE**—Mounted underneath bed section.

**DRIVING BELT**—Endless B-section V-Belt, industrial grade.

**PRESSURE SHEAVES**—2-1/2 in. dia. with 3/8 in. bore.

**IDLER SHEAVE**—4 in. dia. x 5/8 in. bore V type and/or 5-1/2 in. dia. x 5/8 in. bore flat type.

**TAKE-UP**—Take-ups provided to maintain proper V-belt tension. Includes 4-3/8 in. dia. x 5/8 in. bore V type take-up sheave.

**BEARINGS**—Tread rollers have pre-lubricated ball bearings. Flange and pillow block bearings are sealed, pre-lubricated with eccentric lock collar.

**BUTT COUPLINGS**—Standard for connecting 190-ACC, 190-LRS, 190-LRSS, 190-ACZ, or 190-LR conveyors.

**SPEED REDUCTION**—Sealed worm gear speed reducer driven by V-belt. No. 50 roller chain to drive sheave.

**MOTOR**—1/2 HP—230/460V—3 PH. 60 Hz. Totally Enclosed.

**CONVEYING SPEED**—Constant 65 FPM.

**CAPACITY**—500 lbs. total distributed live load.

**FLOOR SUPPORTS**—Now supplied as optional equipment.

Horsepower required to slave-drive LRC's from ACC's affect the lengths of ACC's due to the capacities of the driving V-belt. The four (4) arrangements shown, illustrate basic slave limitations. Other arrangements are possible.

### NOTES

- CURVES MAY BE 30°, 45°, 60°, & 90°
- CURVES ARE NOT ACCUMULATING
- SNUB ROLLER ADJUSTMENT IS ON DRIVE BELT SIDE OF CONVEYOR

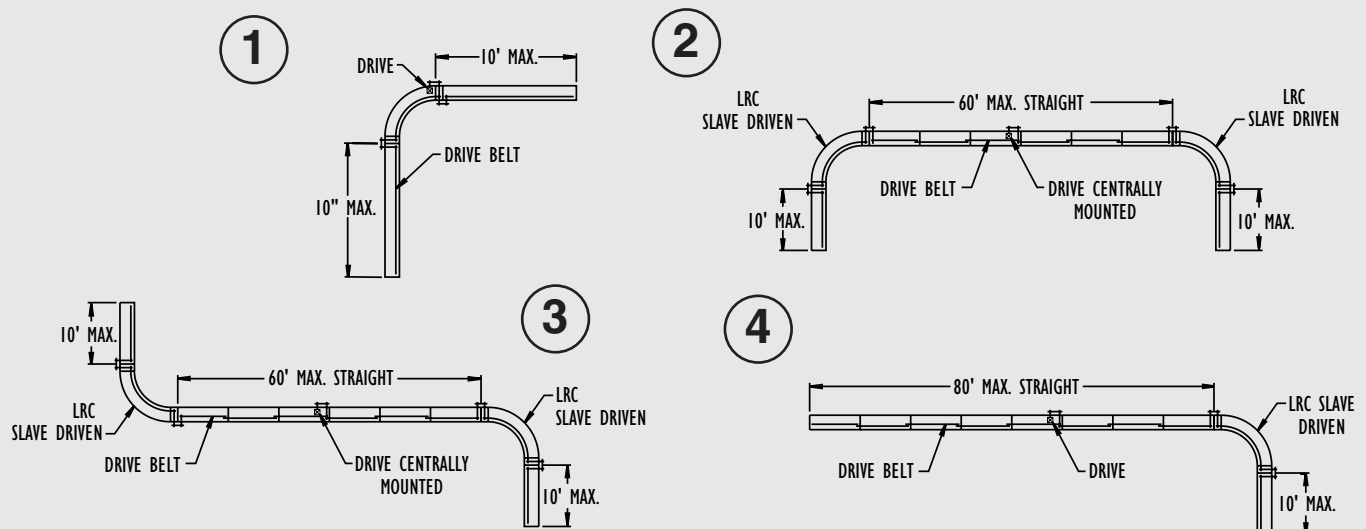

## Optional Equipment

**FLOOR SUPPORTS**—MS Type floor supports are available with a wide range of adjustment. Specify top of belt or roller elevation. One support required at every bed joint and ends of conveyor. Holes in feet for lagging to floor. Knee braces recommended above MS-6 support.

**CONVEYING SPEED**—Other constant and variable speeds from 25 to 120 FPM. **NOTE: Capacity affected with speed change.**

**SIDE MOUNTED DRIVE**—Motor reducer unit mounted to side of conveyor. Specify inside or outside. Minimum elevation 11-1/16 in.

**O-RING DRIVE CHAIN**—With sealed in lubricant (Recommended for applications that do not permit regular lubrication).

**GUARD RAILS**—Continuous adjustable channel, fixed channel or type A & B angle. (See Accessory section.) **NOTE: If product comes in contact with guard rails, product flow will be affected.**

**POLY-TIER SUPPORTS**—36 in. to 120 in. support heights in 6 in. increments. Knee braces supplied.

**CEILING HANGERS**—5/8 in. dia. x 8 ft. long unplated rods fully threaded. Other lengths and galvanized rods available.

**SLAVE DRIVEN**—Standard drive may be omitted and curve slave driven from 190-ACC, 190-ACZ, or 190-LR conveyors. (Specify by sketch, location of slave connection). Minimum elevation 11 in.

**MOTORS**—Energy efficient, single phase, other characteristics. 3/4 HP maximum.

**ELECTRICAL CONTROLS**—Non-reversing or reversible magnetic starters and push-button stations. AC variable frequency drive.