

MODELS	Top of Roller
36 CRRH, 36-CREZD	5-3/8
36 SR - Set High	5-3/8
36 SR - Set Low	4-1/4

Support	NON-ADJ.	Support	NON-ADJ.
HSF-09	4	HSF-20	14-5/8
HSF-10	4-5/8	HSF-21	15-5/8
HSF-11	5-5/8	HSF-22	16-5/8
HSF-12	6-5/8	HSF-23	17-5/8
HSF-13	7-5/8	HSF-24	18-5/8
HSF-14	8-5/8	HSF-25	19-5/8
HSF-15	9-5/8	HSF-26	20-5/8
HSF-16	10-5/8	HSF-27	21-5/8
HSF-17	11-5/8	HSF-28	22-5/8
HSF-18	12-5/8	HSF-29	23-5/8
HSF-19	13-5/8	HSF-30	24-5/8

MODELS	Top of Chain
CT-3000	12
CT-4000	14

Support	NON-ADJ.
CTS-01	1
CTS-02	2
CTS-03	3
CTS-04	4
CTS-05	5
CTS-06	6

MODELS	Top of Belt/ Roller/Conveyor
A - Drive	11-1/4
A - Tail	4-1/2

Support	DRIVE		Support	DRIVE AND TAIL	
	MIN	MAX		MIN	MAX
RSAD-01	15	16-7/16	MSAT-01	11-1/2	13-1/4
RSAD-02	16-7/16	17-7/8	MSAT-02	12-1/2	14-1/4
RSAD-03	17-11/16	19-7/16	MSAT-03	13-1/2	15-1/4
RSAD-04	18-11/16	20-7/16	MSAT-04	14-1/2	17-1/2
RSAD-05	19-11/16	21-7/16	MSAT-05	17-1/8	20-1/8
RSAD-06	20-11/16	23-11/16	MSAT-06	20-1/8	26-1/8
RSAD-07	23-3/16	26-3/16	MSAT-07	24-1/8	30-1/8
RSAD-08	26-3/16	32-3/16	MSAT-08	28-1/8	40-1/8
RSAD-09	30-3/16	36-3/16	MSAT-09	38-1/8	50-1/8
RSAD-10	34-3/16	46-3/16	MSAT-10	50-1/8	62-1/8
RSAD-11	44-3/16	56-3/16	MSAT-11	62-1/8	74-1/8
RSAD-12	56-3/16	68-3/16	MSAT-12	74-1/8	86-1/8
RSAD-13	68-3/16	80-3/16	MSAT-13	84-1/8	96-1/8
RSAD-14	80-3/16	92-3/16	MSAT-14	96-1/8	108-1/8
RSAD-15	90-3/16	102-3/16	-	-	-
RSAD-16	102-3/16	114-3/16	-	-	-

MODELS	Top of Belt/ Roller/Conveyor
R	11-1/4

Support	MIN	MAX	Support	MIN	MAX
RSR-01	13-1/8	14-9/16	RSR-09	28-5/16	34-5/16
RSR-02	14-9/16	16	RSR-10	32-5/16	44-5/16
RSR-03	15-13-16	17-9/16	RSR-11	42-5/16	54-5/16
RSR-04	16-13-16	18-9/16	RSR-12	54-5/16	66-5/16
RSR-05	17-13/16	19-9/16	RSR-13	66-5/16	78-5/16
RSR-06	18-13/16	21-13-16	RSR-14	78-5/16	90-5/16
RSR-07	21-5/16	24-5/16	RSR-15	88-5/16	100-5/16
RSR-08	24-5/16	30-5/16	RSR-16	100-5/16	112-5/16



Casters are easily bolted to conveyor floor supports for portable applications. Steel or rubber wheels available in either rigid or swivel type.

4 in. Caster

- 4 in. dia. steel or rubber wheel
- Swivel or rigid
- Load height-5-5/8 in.
- Swivel radius-3-9/16 in.
- Available with brakes or floor locks

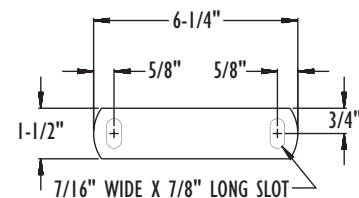
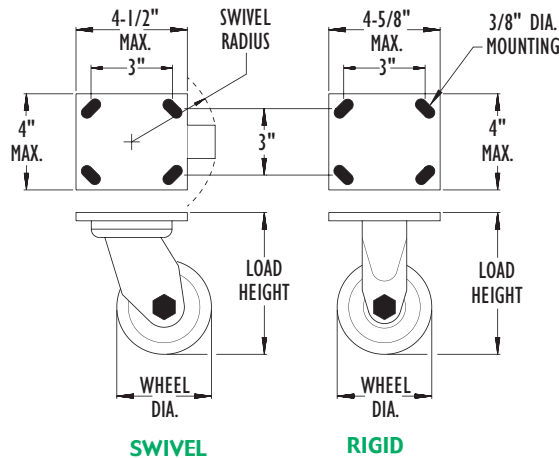

FOOT PLATE FOR FLOOR SUPPORT

6 in. Caster

- 6 in. dia. steel or rubber wheel
- Swivel or rigid
- Load height-7-1/2 in.
- Swivel radius-5 in.
- Available with brakes or floor locks



Caster shown with optional Floor Lock.



Caster shown with optional Brake. Available with Swivel Caster only. 4 in. Caster shown.

NOTE: Casters can limit overall capacity of conveyor.

