

PARTS LIST

ITEM	QTY	PART NUMBER	DESCRIPTION
1	2	S12-08.84X014.438-BCSG	Sheet, 12 Ga. 8 27/32" x 14 7/16"
2	2	RIVET.4X.5-DRIVE	3/8" Steel Drive Rivet
3	1	BOX-BCSG1010-371710	10-1/2" X 10-1/2" X 2-7/16" Cardboard

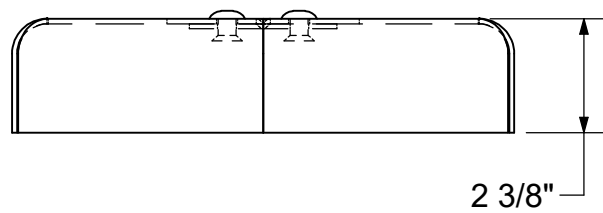
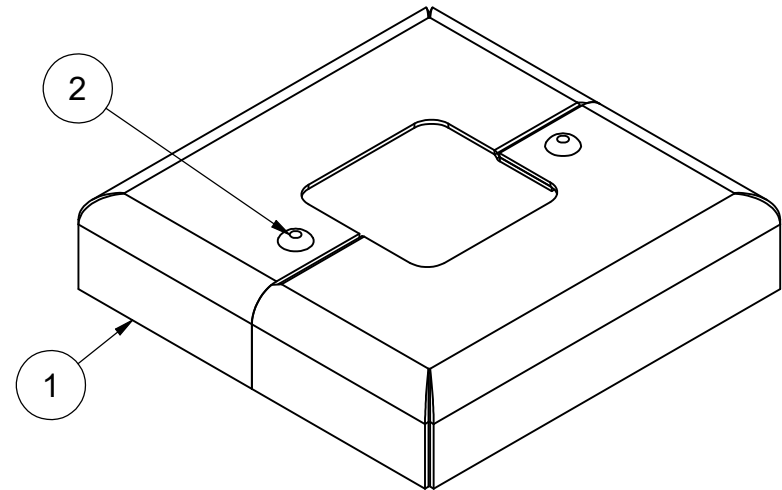
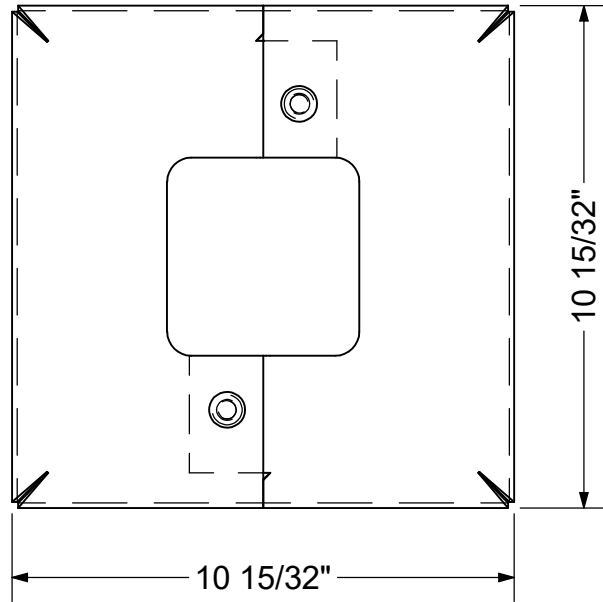

LEGAL NOTICE: By accepting these drawings, you hereby agree that all drawings and designs provided to you by Steel King Industries in connection with this project are and shall remain the exclusive property of Steel King Industries, and may not be duplicated or distributed to third parties, or used in any manner (including manufacturing), without the express written consent of an Officer of Steel King Industries. "Drawings" and "Designs" are inclusive of all formats, including paper, sepi, and electronic. Designs provided by Steel King Industries are provided solely as a courtesy pursuant to the sale of materials, and ownership is not transferred. All rights, including copyright and trademark, shall remain with Steel King Industries. You hereby agree that unless the products shown on these drawings are manufactured or provided by Steel King Industries that Steel King Industries is in no manner whatsoever responsible for the adequacy of said designs. If any field modification work is performed on our products either during or after install that in any way alters it from its original configuration, location, use, state of design or manufacture a Steel King professional Engineer (PE) must approve any field modification work before it is performed. Failure to notify Steel King of field work modifications will void our warranty. In the event that the order is cancelled, all drawings must be immediately returned to Steel King Industries.

WELD DRAWINGS

TYPICAL TOLERANCES FOR DIMENSIONS UNLESS OTHERWISE SPECIFIED:
 FRACTIONAL: +0 / -1/16" | DEGREES: ±0.5°
 DECIMAL: X.XX = ±0.02 | X.XXX = ±0.003

REV.	DATE	DESCRIPTION	BY
-			
		2700 CHAMBER STREET STEVENS POINT, WI 54481	PHONE (715) 341-3120 FAX (715) 341-8792
PART NUMBER & DESCRIPTION			
BCSG1010 GR Base Cover-Special 1 Pair			
NOTES			
DRAWN BY	N. STATS	DATE	5/12/2015
SCALE	NONE		
CAD FILE	00100391.dwg		