

BERRAN
INDUSTRIAL GROUP, INC.

570 Wolf Ledges Parkway, Akron, OH 44311
Phone: (330) 253-5800 | Fax: (330) 253-5805
Online at www.Berran.com



PROUDLY
ASSEMBLED & TESTED



IN THE USA

EAGLE SP11

SEMI-AUTOMATIC STRAPPING MACHINE



DUAL
DIRECT-DRIVE
MOTORS
24 VOLT

"SILENT"
OPERATION

SIMPLE DESIGN =
LESS MAINTENANCE

ALL MACHINES AND PARTS STOCKED IN AKRON, OHIO



Standard Features

- Dual direct-drive 24 volt motors
- "Silent" operation
- Quad locking casters
- Adjustable leg height
- Electronic tension control
- Stainless steel table top
- Safety switch
- Eco friendly

Specifications

- Power requirement: 110VAC / 60Hz
- Strapping width: 6mm to 15mm (1/4" to 5/8")
- Core Size: 8x8 (standard)
- Tension: 0 to 110lbs
- Sealing method: Heat weld
- Machine weight: 149lbs

*** 1-year parts warranty ***

Dimensions

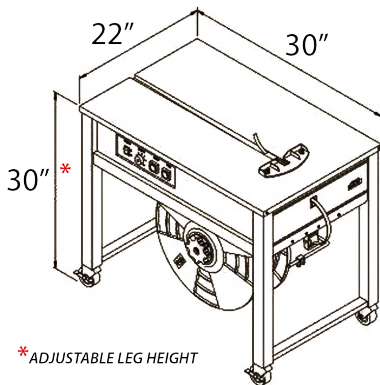

Eagle SP11

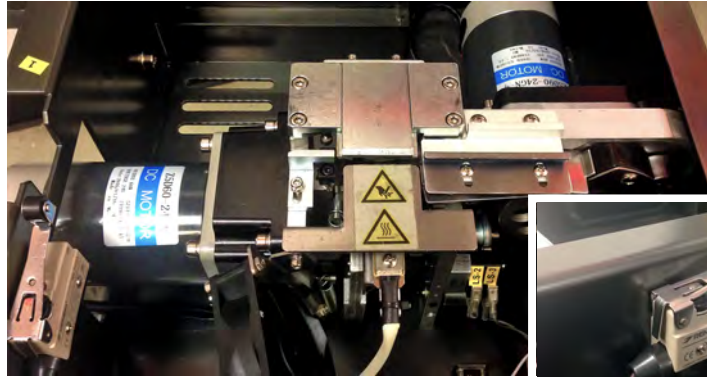

Dual Direct-Drive 24-Volt Motors



Safety Switch



Control Panel



Locking Casters



Adjustable Height

DISTRIBUTED BY

Cisco-Eagle, Inc.
www.cisco-eagle.com
 888-877-3861

