



Operations Manual

Eagle T500 Carton Sealer



**READ ALL INSTRUCTIONS CONTAINED IN THIS
MANUAL PRIOR TO MACHINE INSTALLATION!**

Contents

	<i>page</i>
1. Safety & Warnings	3
2. Specifications	4
3. Setup and Installation	5
3.1 Machine Transportation	5
3.2 Work Height	5
3.3 Tape Head Installation	5
3.4 Power Supply	5
4. Operation	6
4.1 Standard Operation	6
4.2 Work Height Adjustment	6
5. Maintenance & Troubleshooting	7
5.1 Regular Maintenance	7
5.2 Lubrication	7
5.3 Conveyor Belt Adjustment	7
5.4 Carriage Height Adjustment	8
5.5 Typical Faults & Solutions	8
6. Illustrations & Parts List	9
6.1 Replacement Parts	9
6.2 Main Frame Components	9
6.3 Upright Post Assembly	10
6.4 Side Conveyor System	11
6.5 Roller Assembly	12
6.6 Tape Head Guide	13
6.7 Folding Cover	14
6.8 Tape Head Assembly	15
6.9 Front Tape Roller Assembly	16
6.10 Back Roller Side Plate	17
6.11 One-Way Knurled Roller Assembly	18
6.12 Guide Pulley Assembly	18
6.13 Knife Back Plate Assembly	19
6.14 Tape Head Assembly	20
6.15 Guide Tape Wheel Assembly	20
6.16 Tape Holder Assembly	21

1. Safety and Warnings



WHILE OPERATING THE MACHINE, OPERATORS MUST REFRAIN FROM WEARING CLOTHING OR ACCESSORIES THAT MAY GET CAUGHT IN THE MOVING PARTS OF THE MACHINE (WATCHES, RINGS, BRACELETS, TIES, LOOSE CLOTHING, ETC...)

The Eagle T500 is an automatic case sealing machine using pressure-sensitive tape such as PVC or BOPP. It automatically adjusts to the size of the box to seal the top and bottom.

This machine has a wide range of applications including the following industries: chemical fiber, pharmaceutical, publication, refrigeration and air-conditioning, household appliances, ceramics, produce, meats, poultry.

Prior to setting up the machine

1. Verify the model number matches the model number addressed in this manual.
2. Verify that no parts of the machine have been removed or are missing.
3. Remove all packaging or shipping materials used during transport or storage of the machine.
4. Check for any damage that may have occurred during shipping or transport.

Prior to operating the Eagle T500, verify

- Protective shielding and covers are properly installed
- Top and side transfer rollers are present and properly installed
- Machine is on stable ground and casters are in the locked position.

The Eagle T500 is designed to automatically shut down if the control panel is opened while the machine is in operation.



DO NOT USE TO SEAL CARTONS CONTAINING HAZARDOUS SUBSTANCES OR EXPLOSIVE MATERIALS

2. Specifications

Power Requirement	110/220VAC, 50/60Hz (Single Phase)
Air Consumption	1cfm @ 80psi
Sealing Speed	12 cartons per minute
Max. Carton Weight	88lbs (40kg)
Tape Width	2-3in (48-72mm)
Carton Length	12-28in
Carton Width	4.75-19.5in
Carton Height	4.75-20.75in
Machine Length	66in
Machine Width	39.5in
Machine Height	62in
Weight	800lbs
Operational Environment	32-104°F (0-40°C) @ ≤ 98% Humidity
Machine Noise Levels	≤ 75db

3. Machine Setup and Installation



TAKE CARE TO AVOID DAMAGE TO THE MOTOR AND ASSEMBLY WHILE LIFTING OR TRANSPORTING THE MACHINE!

3.1 Transportation

Use a fork lift or tow motor to remove the machine from its shipping container or pallet.

3.2 Working Height Adjustment

While elevated, install the adjustable legs onto the machine. Set each leg to the same height to ensure the machine is level when placed onto the ground.

The working height should be set such that the operator is able to comfortably reach the roller table while maintaining approximately 4in (100mm) of distance from the machine.

3.3 Tape Head Installation

Rest the upper tape head on the carriage placing the notches in the rear of the tape head onto the supporting shaft. Pull out the draw rod by the key ring, lower the tape head and release the key ring. For the lower tape head, remove the front supporting shaft. Rest the rear of the tape head on the rear supporting shaft. Place the front supporting shaft on the angled notches in the front of the tape head and lower the tape head down guiding the pin into the notches in the frame.

Check tape cutter position and adjust as needed.

3.4 Connect Power Supply

Connect the machine to the power supply.

Note: Prior to connecting the machine to the power supply, verify that the power switch is set to the 'OFF' position and that the work area is clean and clear of any items.

4. Operation

4.1 Standard Operation

Prior to operating the machine, please confirm that

1. The proper voltage is being supplied to the motor
2. All fasteners and protective covers are securely in place
3. All electronic components are dry

Machine Operation

1. Plug the machine into the power source
 - a. DO NOT hard wire the machine to the power source
2. Adjust horizontal and vertical guides to accommodate cartons to be sealed
3. Press the button labeled 'Start'
4. Verify belt movement direction
5. Place carton to be sealed into the feed side of the machine
 - a. Cartons must be placed in the center of the roller table for proper feed through the machine

After operating the machine for two to five minutes, check the following

1. Horizontal guide adjustment lever is firmly in place and belts do not have excess slack
 - a. Belt deviation (slack) should be checked once every ten days
 - b. Adjust belt tension as needed
2. Vertical guide adjustment is firmly in place and belts do not have excess slack
 - a. Belt deviation (slack) should be checked once every ten days
 - b. Adjust belt tension as needed
3. Verify that tape is being dispensed in a consistent manner that ensures a smooth application onto the carton being fed through the machine.



TURN OFF MACHINE AND DISCONNECT IT FROM THE POWER SOURCE PRIOR TO PERFORMING ANY MAINTENANCE OR SERVICE

4.2 Adjustable Work Height

Put the nut plate into the leg support according to the figure.

Then loosely connect the fastening piece and the nut plate with the socket head cap screws. Insert the leg between the leg support and nut plate. The leg can now be adjusted up and down as desired. Tighten the screws.

The working height should be set such that the operator is able to comfortably reach the roller table while maintaining approximately 4in (100mm) of distance from the machine.

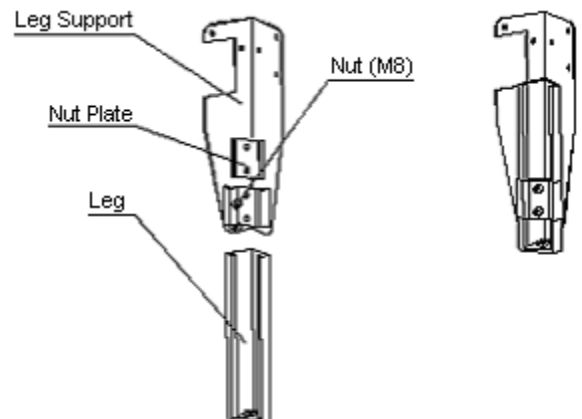

5. Maintenance and Troubleshooting



TURN OFF MACHINE AND DISCONNECT IT FROM THE POWER SOURCE PRIOR TO PERFORMING ANY MAINTENANCE OR SERVICE

5.1 Regular Maintenance & Cleaning

1. Check all bolts and screws regularly to ensure smooth, malfunction-free operation of the machine.
2. Lubricate moving parts of the machine on a regular basis.
3. Clean the machine surfaces.
4. Clean off any tape residue from the cutting blade daily.
5. If the machine is to be stored for an extended period of time, the cutting blade should be oiled prior to being placed in storage.

5.2 Lubrication

1. The driving chain should be lubricated once a month.
2. The bearings should be lubricated once a month.
3. The transmission axle, driving chain and bearing should be lubricated once a week.
4. All other moving parts should be lubricated on a regular basis.

5.3 Conveyor Belt Adjustment

Adjustments are made using the adjustable bolt located at the end of the side conveyer system.

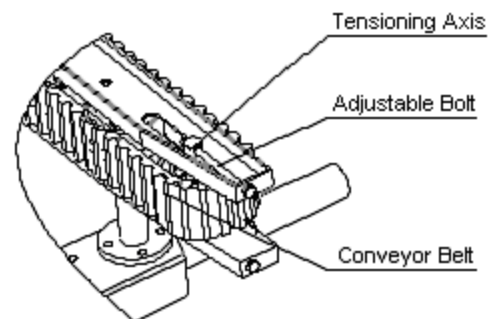

5. Maintenance & Troubleshooting

5.4 Carriage Height Adjustment

Rotate the height adjustment handle by hand to adjust the carriage height.

Rotate the handle clockwise to move the carriage up and counter clockwise to move the carriage down.

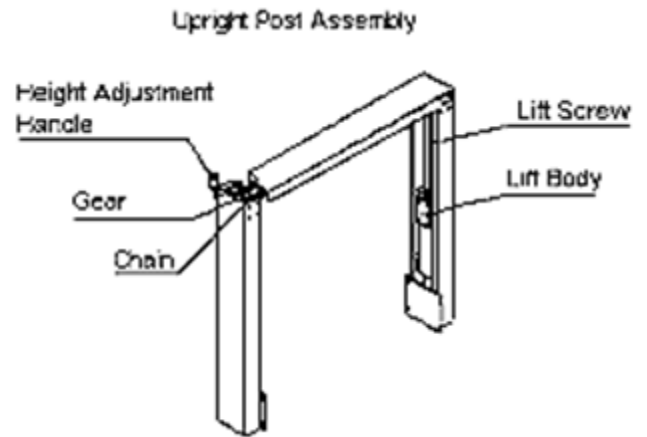

5.5 Typical Faults & Solutions

Fault	Solution
Tape is not centered on the carton.	Adjust the tape positioning knob on the tape head dispenser.
Scratched carton caused by tape cutting blade.	Adjust tape cutting blade position.
Tape is not properly adhering to the carton. (Caused by forward tape transfer wheel not applying sufficient force)	Adjust front wheel spring to increase force.

6. Illustrations & Parts List

6.1 Replacement Parts

	Description	Part Number	Qty
1	Drum	FJG-3A-96	
2	Belt	-	3,370mm
3	Chain	06B	
4	Wheel	FJ-3A-118	
5	Transmission Shaft	FJ-3A-90	
6	Drive Wheel	FJ-3A-117	

6.2 Main Frame Components

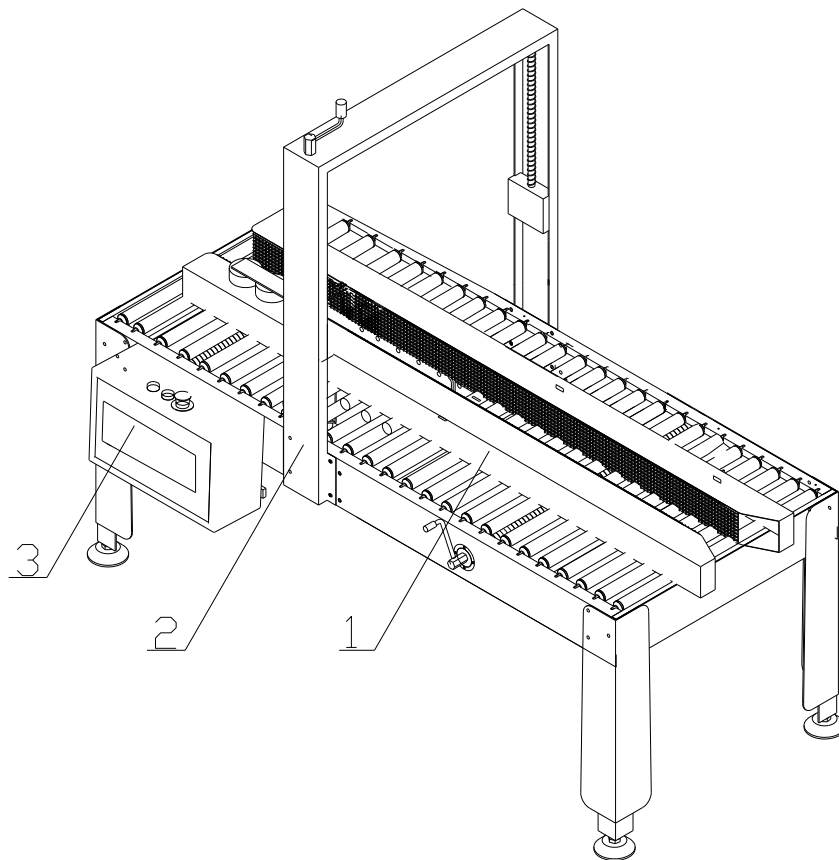

	Description	Part Number	Qty
1	Side Conveyor	-	1
2	Upright Post Assembly	-	1
3	Electric Box	FJ-3A-20	1

6. Illustrations & Parts List

6.3 Upright Post Assembly

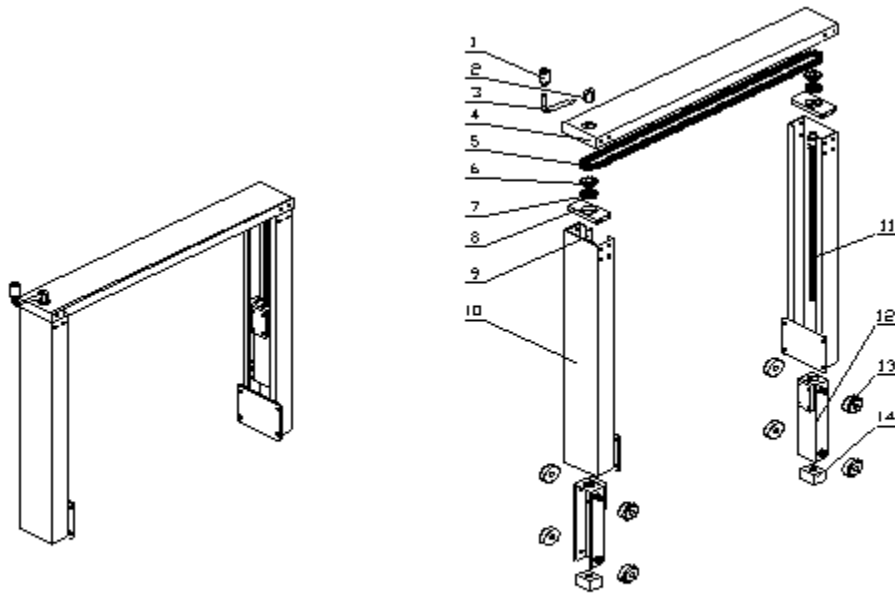

	Description	Part Number	Qty
1	Handle	FJ-3A-112	1
2	Hub	FJ-3A-112	1
3	Handle Mount	FJ-3A-114	1
4	Beam	FJ-3A-37	1
5	Chain	06B	1
6	Height Adjustment Gear	FJ-3A-131	2
7	Lift Screw Bearing	6905-2Z	2
8	Upper Support Board	FJ-3A-64	2
9	Lift Screw (Left)	FJ-3A-129	1
10	Upright Post Body	FJ-3A-8	2
11	Lift Screw (Right)	FJ-3A-130	2
12	Lift Body	FJ-3A-10	2
13	Idler Wheel	FJ-3A-140	4
14	Nut	FJ-3A147	2

6. Illustrations & Parts List

6.4 Side Conveyor System

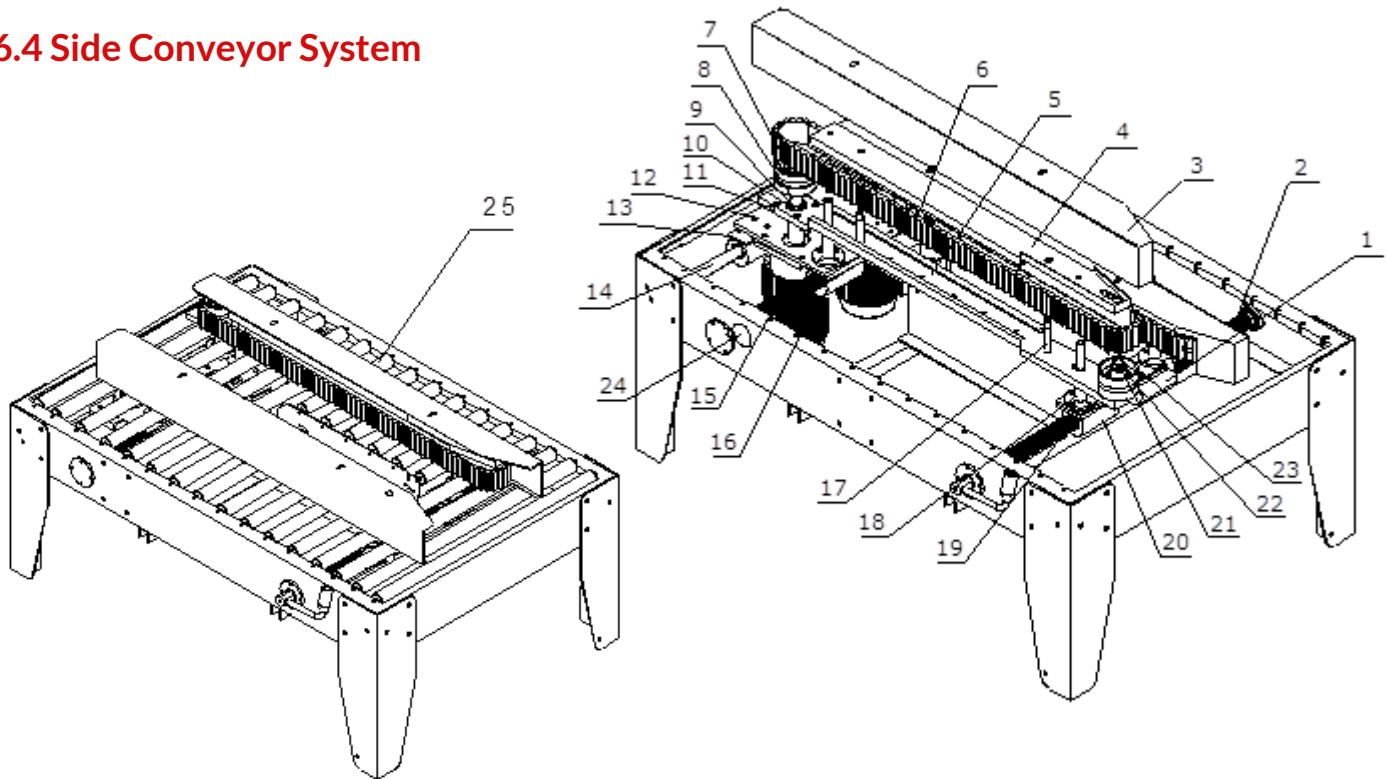

	Description	Part Number	Qty
1	Right Lead Nut	FJ-3A-143	2
2	Lead Screw (Left/Right)	FJ-3A-91	1
3	Cover Plate	FJ-3A-67	1 ea. side
4	Side Belt Cover	FJ-3A-70	1 ea. side
5	Conveyor Support Base	FJ-3A-72	1 ea. side
6	Belt	-	3,370mm (x2)
7	Drive Roller	FJ-3A-117	2
8	Transmission Shaft	FJ-3A-90	2
9	Driver Wheel Sleeve	FJ-3A-141	2
10	Conveyor Bearing	6005	2
11	Bearing Base	FJ-3A-116	2
12	Motor Mount Panel	FJ-1A-302	2
13	Sliding Sleeve	FJ-3A-97	2
14	Guide Shaft	FJ-3A-135	1
15	Lead Screw (Left/Right)	FJ-3A-92	1
16	Motor	CV200-20ZG1/G2	2
17	Locating Pins	FJ-3A-101	4
18	Connection Pole	FJ-3A-100	4
19	Orientation Plate	FJ-3A-109	2
20	Left Lead Nut	FJ-3A-142	2
21	Tensioning Shaft	FJ-3A-87	2
22	Tension Wheel Sleeve	FJ-3A-119	4
23	Wheel	FJ-3A-118	2

24	Width Adjustment Gear	FJ-3A-111	2
25	Roller Assembly	FJ-3A-96	

6. Illustrations & Parts List

6.5 Roller Assembly

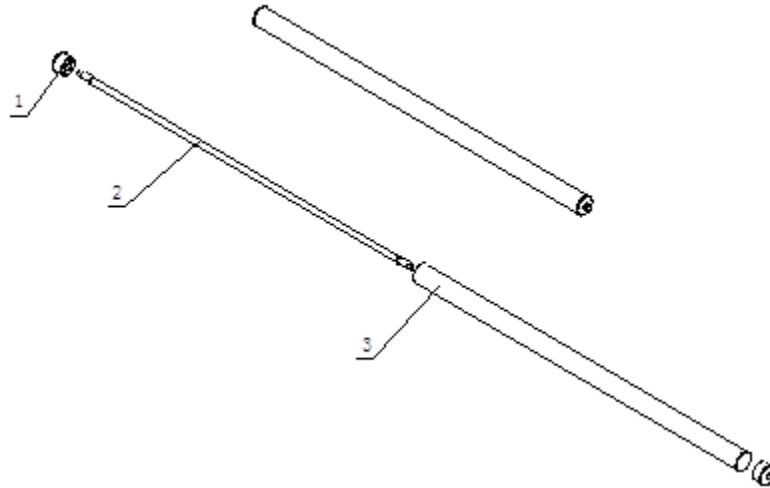

	Description	Part Number	Qty
1	Supporting Ring	32 Dia. Roller	2 sets
2	Long Shaft	FJ-3A-95	1
	Short Shaft	FJ-3A-94	1
3	Roller	FJ-3A-96	1

6. Illustrations & Parts List

6.6 Tape Head Guide Mount

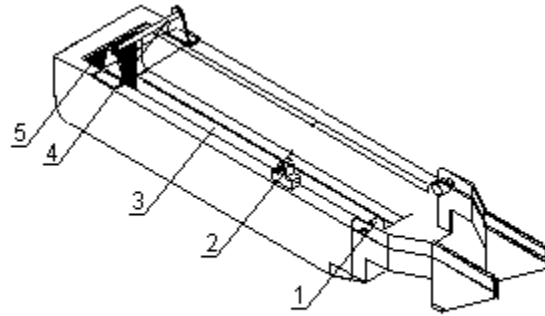

	Description	Part Number	Qty
1	Spacer	FJ-3A-85	1
2	Fixed Block	FJ-3A-63	1
3	Tape Head Bracket	FJ-3A-22	1
4	Support Shaft	FJ-3A-86	1
5	Wipe Down Brush	-	1

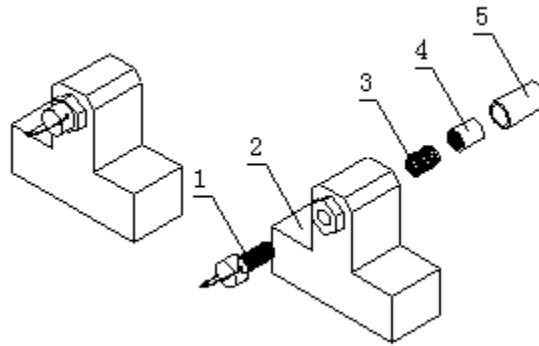

	Description	Part Number	Qty
1	Pull Bar	FJ-3A-122	1
2	Bearing Base	FJ-3A-123	1
3	Fixed Block	FJ-3A-63	1
4	Compression Spring	FJ-3A-120	1
5	Slide Block	FJ-3A-121	1

6. Illustrations & Parts List

6.7 Folding Cover

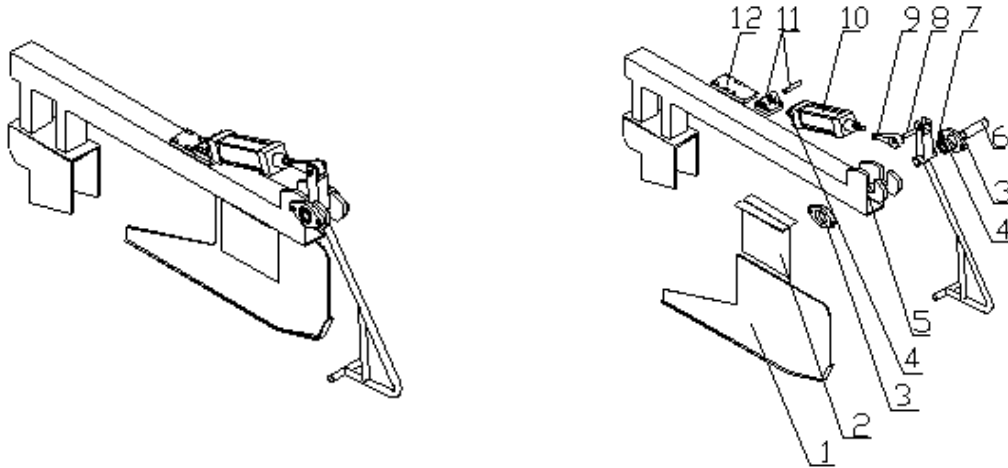

	Description	Part Number	Qty
1	Minor Flap Hold Down	FJ-3A-57	1
2	Support for Minor Flap Hold Down	FJ-3A-62	1
3	Bearing Base	LF203	2
4	Bearing	-	1
5	Upper Support Bracket	FJ-3A-50	1
6	Folder Support Pin	-	1
7	Folder Arm	FJ-3A-56	1
8	Folder Pin	-	1
9	Bearing	-	1
10	Cylinder	SC40x80	1
11	Cylinder Base	SC40-CA/CB	1
12	Cylinder Mounting Base	-	1

6. Illustrations & Parts List

6.8 Tape Head Assembly

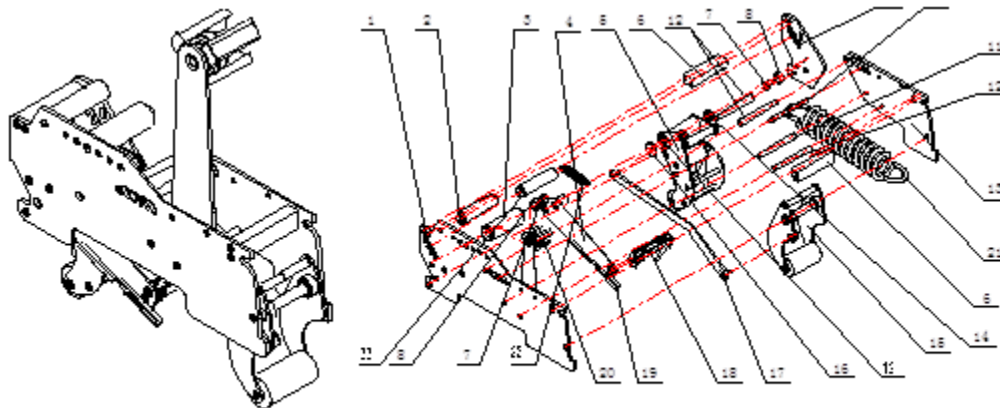

	Description	Part Number	Qty
1	Side Plate	FJ-01-17	1
2	Guide Pulley Assembly	-	1
3	One Way Roller Assembly	-	1
4	Blade Carrier	FJ-01-04	1
5	Front Roller Assembly	-	1
6	Block	FJ-01-00	1
7	Shaft	FJ-00-12	2
8	Stop	FJ-40-00	2
9	Side Plate (x3)	FJ-01-02	1
10	Shaft	FJ-00-02	1
11	Shaft	FJ-00-07	1
12	Shaft	FJ-00-06	4
13	Side Plate (x2)	FJ-01-16	1
14	Shaft Cover	FJ-02-09	1
15	Back Roller Side Plate Assembly	-	1
16	Brass Washer	FJ-02-04	1
17	Connecting Lever	FJ-01-14	1
18	Knife Back Plate Assembly	-	1
19	Knife Leveling Piece	FJ-01-01	1
20	Tape Hub Assembly	-	1
21	Extension Spring	FJ-H-07	1
22	Extension Spring Axis	FJ-00-01	1
23	Extension Spring	FJ-H-04	1

6. Illustrations & Parts List

6.9 Front Tape Roller Assembly

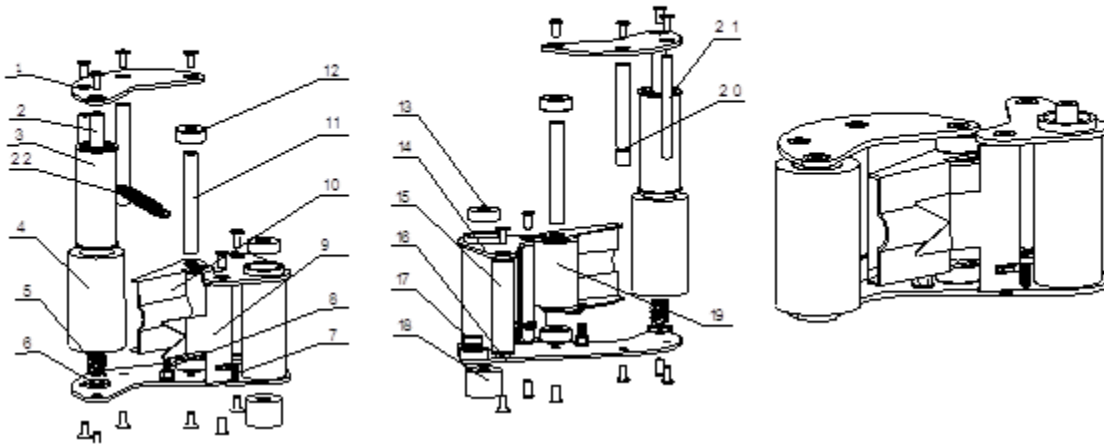

	Description	Part Number	Qty
1	Front Plate	FJ-01-09	1
2	Shaft	FJ-00-08	1
3	Roller Shaft	FJ-E-38-01	1
4	Idler Wheel	FJ-E-41-01	1
5	Press Spring	FJ-11-00	1
6	Gasket	FJ-50-100	1
7	Phillips Flat Head Screw	M4x12	1
8	Phillips Flat Head Screw	M5x15	1
9	Tape Holder Assembly	-	1
10	Tape Guide Assembly	FJ-01-08	1
11	Shaft	FJ-00-10	1
12	Axle Sleeve	FJ-02-02	2
13	Bearing	6900Z (1080900)	1
14	Front Roller	FJ-50-00	1
15	Guide Tape Wheel Assembly	-	1
16	Washer	-	1
17	Bearing	688Z (208088)	1
18	Bearing	7942/20	1
19	Axle Sleeve	FJ-02-10	1
20	Shaft	FJ-00-11	1
21	Shaft	FJ-00-09	1
22	Return Spring	FJ-H-00	1

6. Illustrations & Parts List

6.10 Back Roller Side Plate Assembly

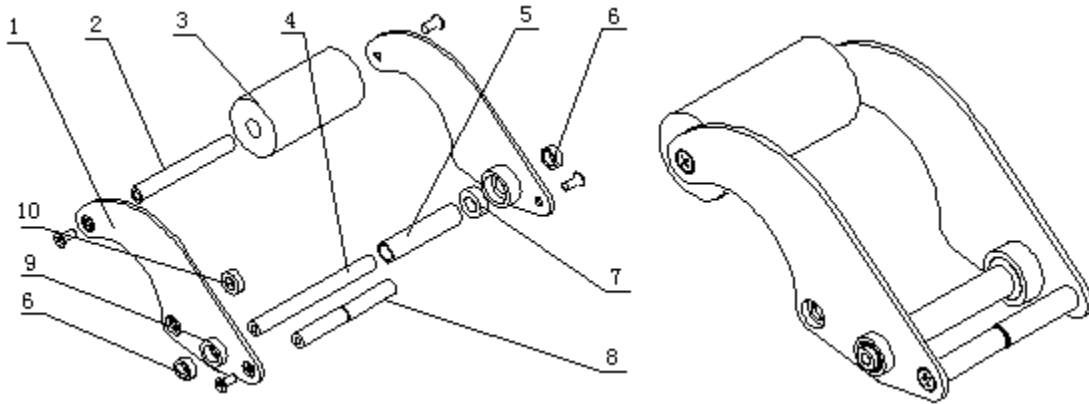

	Description	Part Number	Qty
1	Back Plate	FJ-01-13	1
2	Shaft	FJ-00-10	1
3	Idler Wheel	FJ-40-03	1
4	Shaft	FJ-00-06	1
5	Axle Sleeve	FJ-02-05	1
6	Axle Sleeve	FJ-02-06	2
7	Bearing	6800Z (26800)	2
8	Shaft	FJ-00-05	1
9	Axle Sleeve	FJ-02-00	1
10	Bearing	688Z (208088)	1

6. Illustrations & Parts List

6.11 One Way Knurled Roller Assembly

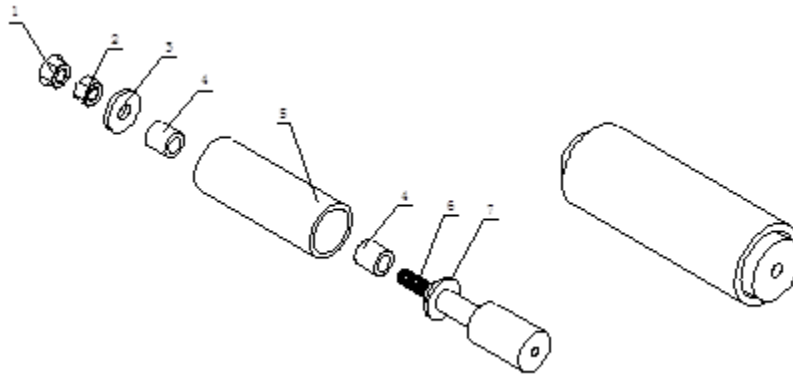

	Description	Part Number	Qty
1	Locknut	M8	1
2	Nut	M8	1
3	Washer	FJ-02-03	1
4	Bearing	HF1216	1
5	One Way Wheel	FJ-E-31-01	1
6	Shaft	FJ-00-04	1
7	Axle Sleeve	FJ-02-01	1

6.12 Guide Pulley Assembly

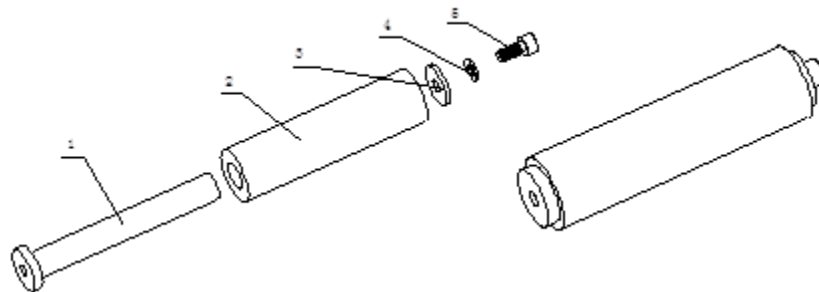

	Description	Part Number	Qty
1	Shaft	FJ-00-03	1
2	Axle Sleeve	FJ-02-07	1
3	Washer	5	1
4	Washer	5	1
5	Socket Head Cap Screw	M5x12	1

6. Illustrations & Parts List

6.13 Knife Back Plate Assembly

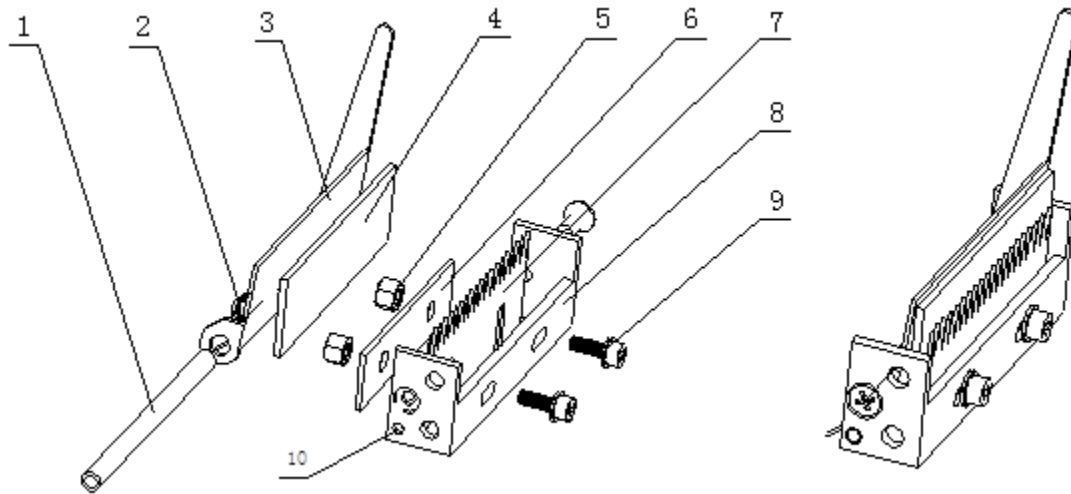

	Description	Part Number	Qty
1	Shaft	FJ-00-00	
2	Torsion Spring	FJ-H-05	
3	Protecting Blade Carrier	FJ-01-06	
4	Sponges	-	
5	Nut	M4	
6	Knife Board	FJ-40-04	
7	Blade	-	
8	Blade Carrier Block	FJ-01-07	
9	Socket Head Cap Screw	M4x16	
10	Phillips Flat Head Screw	M4x12	

6. Illustrations & Parts List

6.14 Tape Hub Assembly

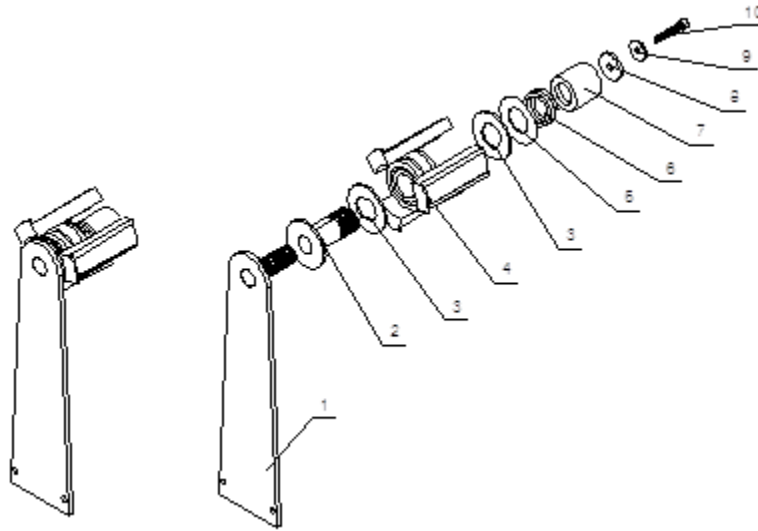

	Description	Part Number	Qty
1	Tape Frame	FJ-05-00	1
2	Axle Sleeve	FJ-02-12	1
3	Antiskid Slice	FJ-05-01	2
4	Tape Head Drum	FJ-02-05-03	1
5	Gasket	FJ-05-02	1
6	Press Spring	FJ-H-08	1
7	Shaft	FJ-00-14	1
8	Bearing Bush	FJ-02-08	1
9	Washer	5	1
10	Socket Head Cap Screw	M5x40	1

6.15 Guide Tape Wheel Assembly

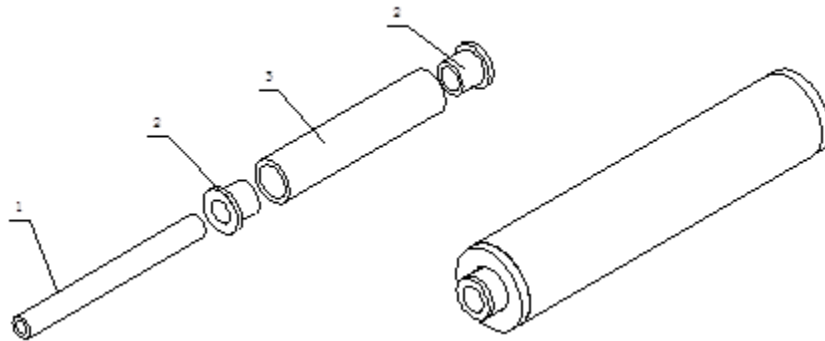

	Description	Part Number	Qty
1	Shaft	FJ-00-09	1
2	Axle Sleeve	FJ-02-14	2

3	Guide Tape Wheel	FJ-02-13	1
---	------------------	----------	---

6. Illustrations & Parts List

6.16 Tape Holder Assembly

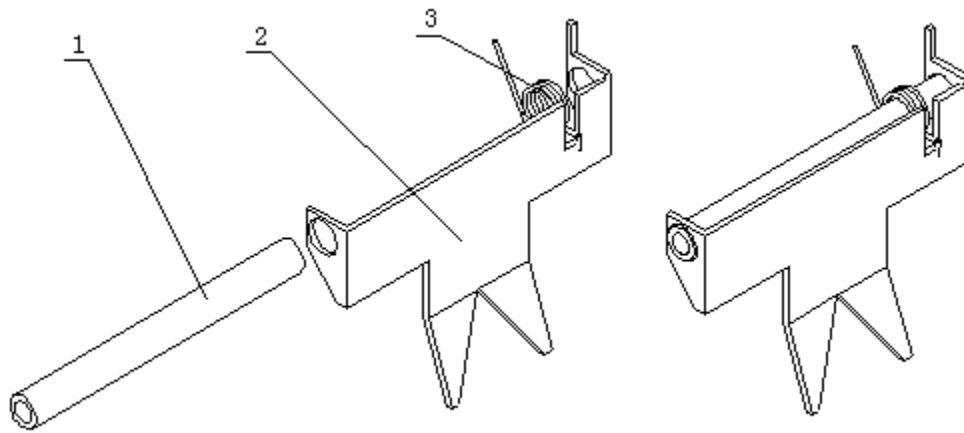

	Description	Part Number	Qty
1	Shaft	FJ-00-09	1
2	Press Tape Board	FJ-01-05	1
3	Torsion Spring	FJ-H-03	1