

MobiLift®

BX & BXB MOBILE LIFT TABLES

Working Harder To
Make Your Life Easier

MobiLift BX & BXB (battery / charger not shown)

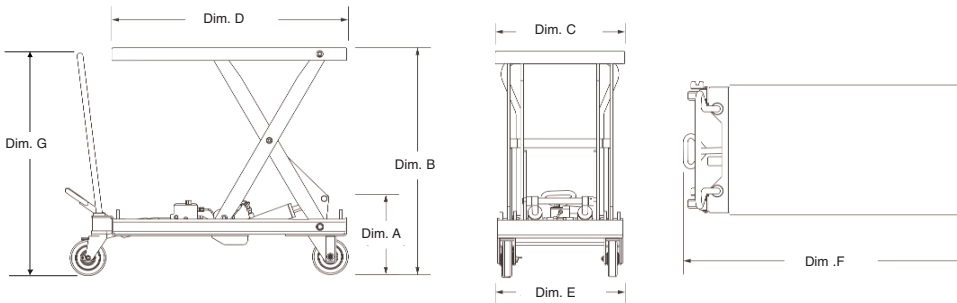

Selector Table for BX Series Mobile Lift Tables

Model	Travel (in)	Capacity* (lb)	Platform Height (in)		Platform Size (in)		Overall Size (in)			Strokes Or Lift Speed To Max. Ht.	Shipping Weight (lb)
			Min. (A)	Max. (B)	Width (C)	Length (D)	Width (E)	Length (F)	Height (G)		
BX-15	20.4	330	8.4	28.8	17.7 x 27.6	17.7 x 33.6 x 31.3	15	75			
BX-25	22.7	660	11.3	34.1	19.7 x 32.0	19.7 x 39.7 x 35.3	25	200			
BX-50	22.1	1100	17.2	39.3	20.4 x 39.8	20.5 x 46.9 x 37.8	50	300			
BX-75	22.1	1760	17.2	39.3	20.4 x 39.8	20.5 x 49.5 x 37.8	67	300			
Double Scissor Models											
BX-30S	45.1	660	17.0	62.1	20.4 x 39.8	20.5 x 49.5 x 37.8	64	340			
BX-50S	23.0	1100	16.5	39.5	18.1 x 25.6	18.1 x 37.2 x 37.0	66	275			
BX-50W	45.1	1100	17.0	62.1	20.4 x 39.8	20.5 x 49.5 x 37.8	90	380			
Stainless Steel Models											
BXS-10	20.4	220	8.4	28.8	17.7 x 27.6	17.7 x 33.6 x 31.3	15	75			
BXS-20	22.7	440	11.3	34.1	19.7 x 32.0	19.7 x 39.7 x 35.3	25	200			
Battery Operated Models											
BX-30B	23.5	660	11.5	35.0	19.7 x 32.1	19.7 x 41.7 x 34.6	10 Sec.	280			
BX-50B	23.1	1100	17.2	40.4	20.5 x 39.8	20.4 x 50.0 x 37.4	10 Sec.	390			
BX-80B	21.1	1760	17.2	38.4	20.5 x 39.8	20.5 x 49.4 x 37.4	12 Sec.	400			
Double Scissors Battery Operated Models											
BX-15WB	39.0	330	15.2	54.1	19.7 x 32.1	19.7 x 39.7 x 35.4	10 Sec.	330			
BX-30SB	46.3	660	17.5	63.8	20.5 x 39.8	20.4 x 50.0 x 37.4	12 Sec.	450			
BX-50WB	46.1	1100	17.1	63.2	20.5 x 39.8	20.4 x 50.0 x 37.4	17 Sec.	490			

Standard Features - All Models

- Heavy-duty construction with captured scissor rollers for maximum stability
- High quality casters and wheels for exceptional rollability
- Foot actuated caster brake
- Heavy duty maintenance scissor lock pin
- Durable powder coated finish

Standard Features - Manual

- Superior hydraulic systems feature an integrated pump-cylinder for maximum reliability
- Ergonomic push handle with convenient lowering control
- Lowering control automatically stops when released for added safety

Standard Features - Electric Models

- Removable push-button control on cord with convenient handle mount
- Ergonomic handle with integrated safety mesh
- Easily accessible On/Off switch with integrated circuit breaker
- Enclosed automatic charger with removable power cord
- Green-Yellow-Red indicator lights provide quick indication of battery charge
- Easily accessible, adjustable lowering speed control
- Upper travel limit switch



Convenient Hand-Lever Lowering Control For Model BX



Removable Pendant Push-Button Control in Handle Mount (BXB)

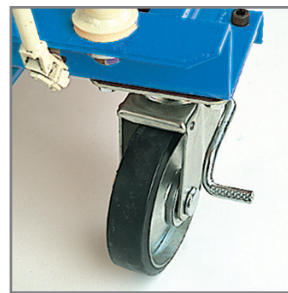

Dual-Action Caster Brake Locks Wheel and Swivel



DISTRIBUTED BY:

Cisco-Eagle
www.cisco-eagle.com
888-877-3861