

Drawer Assembly

Part #s

DRW03/DRW2403
 DRW06/DRW2406 (single drawer fig - 1)
 DRW12/DRWF12/DRW2412
 DRW26/DRW2426
 DRW612/DRWF612/DRW24612
 DRW36/DRW2436 (stacked drawer fig - 2)
 DRW212/DRW24212
 DRW3612/DRW243612

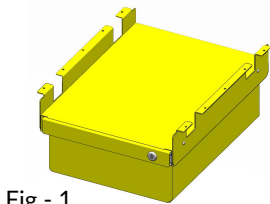

Fig - 1

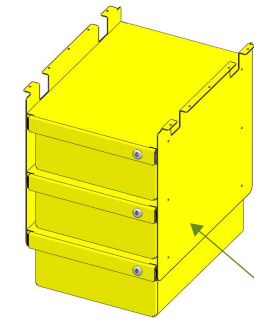

Fig - 2

Side mounting brackets

Qty	Components
8-10	#12 x 3/4" Phillips pan head sheet metal screw
1	Single drawer or stacked drawer assembly

Tool List

#3 Phillips screwdriver, or
 impact driver with #3 Phillips bit

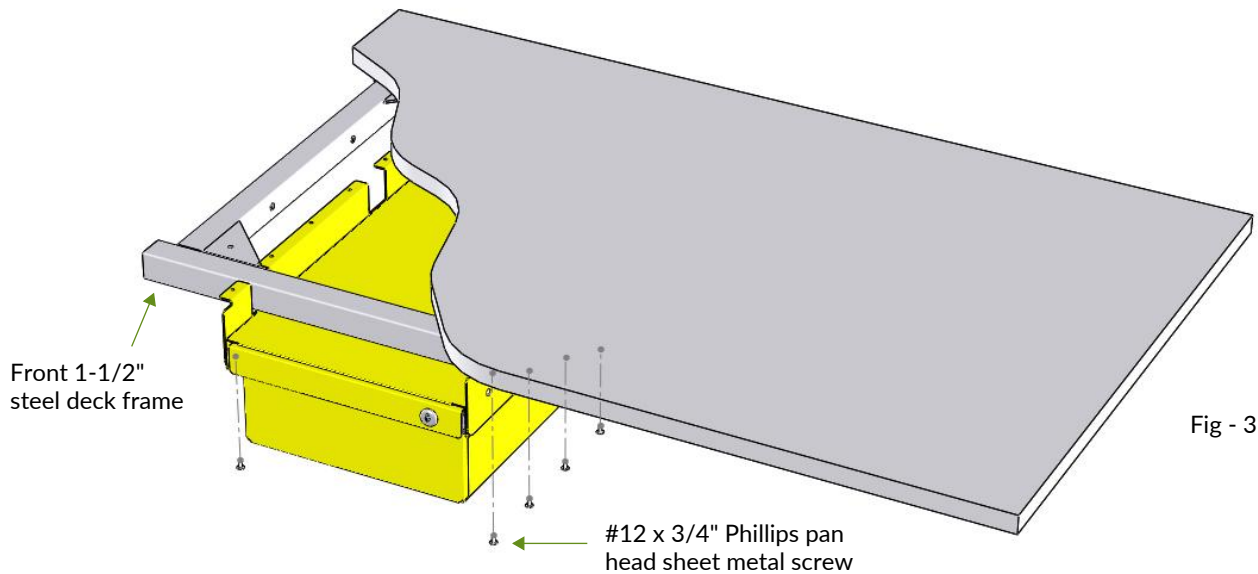

- 1 Position drawer assembly under workstation in desired location with the side mounting brackets fitting around the front 1-1/2" steel deck frame.
- 2 Secure the drawer to the underside of the work surface using the #12 x 3/4" Phillips pan head sheet metal screws provided (See Fig - 3).

DRW24XXXX drawers attach using eight screws.