

## Leveling Workstation Deck Frame

### Workstation Part Prefix

PB	AF
PBC	AFC
PBH	AFH
PBHC	AFHC

### Tool List

1/2" wrench

Ratchet with 1/2" socket, or  
impact driver with 1/2" socket

Flathead screwdriver

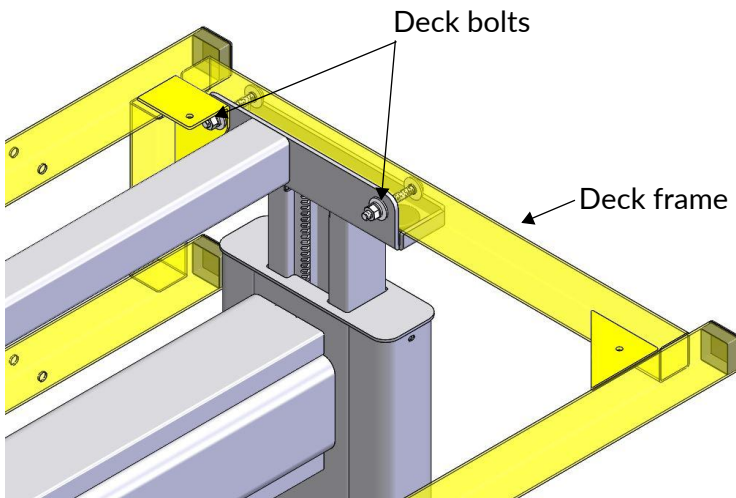

Fig - 1

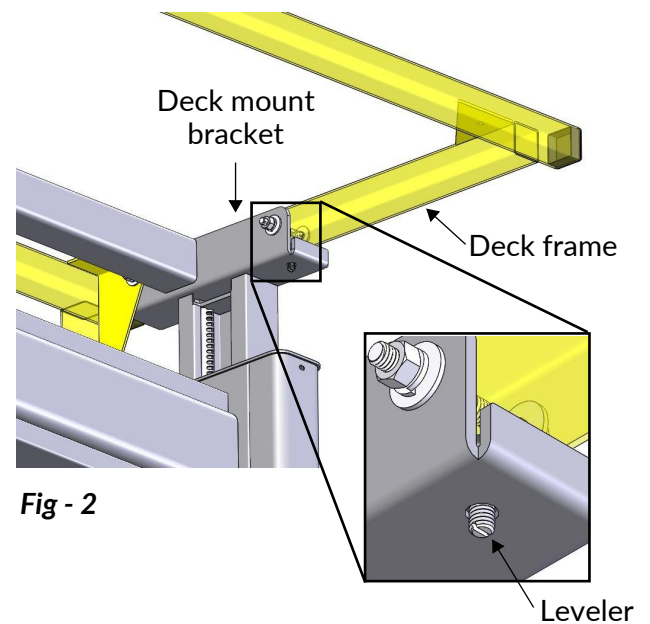

Fig - 2

- 1 Loosen deck bolts, two on each side of workstation, with 1/2" wrench and ratchet (Fig-1)
- 2 Pick up on front of work surface
- 3 Rotate leveler on underside of deck mount bracket with flathead screwdriver until work surface is level (Fig-2)
- 4 Re-tighten deck bolts (Fig-1)