



Profit from the Eagle Advantage®

Specification Sheet

Short Form Specifications

All stainless steel type 430 enclosed cabinet. Three adjustable shelves on 4" centers, 24"-deep by 36"- or 48"-long. Available with slanted top for laminar flow.



#VSC2436-3 vertical storage cabinet

Options / Accessories

- 5" plate casters w/brake (factory-installed) *
- Additional 36"-long shelves
- Additional 48"-long shelves

* To order casters, add suffix "-CPB5". Example: VSC2436-3-CPB5

Item No.:	_____
Project No.:	_____
S.I.S. No.:	_____

Vertical Storage Cabinets

MODELS:

- | | | |
|------------------------------------|-------------------------------------|--------------------------------|
| <input type="checkbox"/> VSC2436-3 | <input type="checkbox"/> VSCS2436-3 | <input type="checkbox"/> VSC36 |
| <input type="checkbox"/> VSC2448-3 | <input type="checkbox"/> VSCS2448-3 | <input type="checkbox"/> VSC48 |
| <input type="checkbox"/> VSC2436-4 | <input type="checkbox"/> VSCS2436-4 | |
| <input type="checkbox"/> VSC2448-4 | <input type="checkbox"/> VSCS2448-4 | |

Design and Construction Features

- Features 18 gauge type 430 stainless steel cabinet body.
- Shelves adjustable on 4" (102mm) vertical centers.
- Double-pan 20 gauge stainless steel hinged doors.
- Transverse rod handles featuring keyed locks.
- All units are 24" (610mm) front-to-back.
- Available in 36" and 48" (914 and 1219mm) lengths.
- Available with flat top or slanted top.
- Custom sizes available.

Certifications / Approvals



Item No.: _____
 Project No.: _____
 S.I.S. No.: _____

Vertical Storage Cabinets

Units with Flat Top

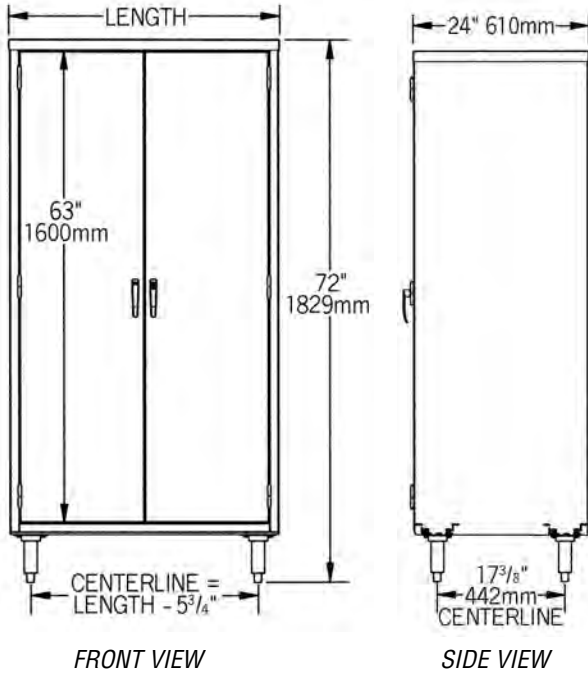

Units with Slanted Top

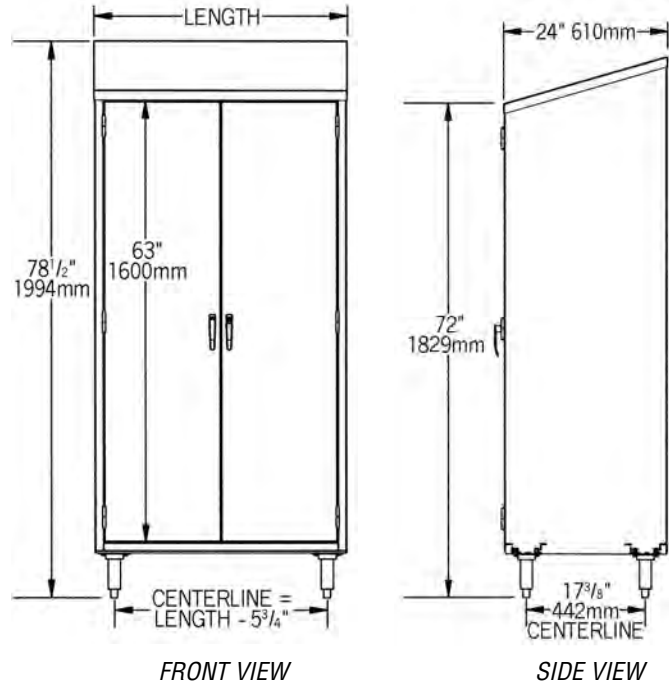

Units with Flat Top

Units with Slanted Top

Units with 3 Shelves			Units with 4 Shelves			Units with 3 Shelves			Units with 4 Shelves			wt. capacity					
model #	lbs.	kg	model #	lbs.	kg	model #	lbs.	kg	model #	lbs.	kg	width	length	per shelf			
												in.	mm	in.	mm	lbs.	kg
VSC2436-3	413	187.3	VSC2436-4	416	188.7	VSCS2436-3	416	188.7	VSCS2436-4	419	190.1	24"	610	36"	914	150	68.0
VSC2448-3	485	220.0	VSC2448-4	490	222.3	VSCS2448-3	488	221.4	VSCS2448-4	495	224.5	24"	610	48"	1219	200	90.7

Optional Additional Shelves

model #	description	weight	lbs.	kg
VSC36	fits 36" (914mm) long cabinets	25	11.3	
VSC48	fits 48" (1219mm) long cabinets	30	13.6	