

Product Options

Corrosion-Resistant Chain

Harrington's Nickel-Diffused (ND) Chain is designed for use in corrosive environments where saltwater, rain, steam, and many acidic and alkaline solutions are prevalent. The specific temperature, concentration, and duration of exposure will affect the corrosion rate of the chain. Please consult factory for assistance.

Chain Containers

Harrington offers a broad range of chain containers for use with manual hoist products. These feature the same industrial quality construction as the containers available for our electric hoists.

- Chain containers are available in three basic sizes: 05, 10 and 15.
- Containers are constructed from vinyl-coated canvas with a steel frame on top.
- The containers are prepared differently depending on the hoist model.
- CF and NTH model hoists must be disassembled to install a container and must be load tested after assembly. The containers should be installed by Harrington or a repair company capable of performing load tests.

Latch Kits

Each Harrington latch kit contains a steel latch, stainless steel latch spring, attachment clamp, and all required hardware. The clamp attaches tightly to the hook neck, while finger lugs on each side of the latch allow it to be opened easily with either hand. A centering indentation on the bottom of the latch prevents the latch from slipping off the hook point. Harrington latch kits come in 13 standard sizes and can be custom manufactured for other neck and throat openings. Stainless steel hook latches are available for specialty applications. Consult Customer Service for more information.

CB WITH CHAIN CONTAINER

Hoist Product Code	Maximum Lift (ft)	
	Size 05	Size 10
CB005	39	68
CB010	39	68
CB015	28	49
CB020	22	39
CB025	22	38
CB030	14	24
CB050	11	19

CF WITH CHAIN CONTAINER

Hoist Product Code	Maximum Lift (ft)	
	Size 05	Size 10
CF005	39	68
CF010	39	68
CF015	28	49
CF020	20	34
CF030	14	24
CF050	9	16

NTH WITH CHAIN CONTAINER

Hoist Product Code	Maximum Lift (ft)		
	Size 05	Size 10	Size 15
NTH010	39	68	134
NTH020	20	34	67
NTH030	14	24	48
NTH050	9	16	32

Load Limit Warning Handle

An LB lever hoist equipped with a load limit warning handle alerts the operator when the hoist is being used to lift damaging loads beyond rated capacity. The load limit warning handle signals the operator in three ways:

- Sight: The green signal changes to red.
- Feel: The load handle deflects 15-degrees.
- Sound: The handle emits a click when deflected.

The handle resets when you operate the hoist in the down direction.

Top Hook Extenders

LB lever hoists are available with a top hook extender that locates the hoist body away from its attachment point. The top hook extender is 18 inches long and is available for 3/4 through 3 Ton LB lever hoists.

Point Load Hook

Harrington offers a special hook for the 1 1/2 and 3 Ton LB lever hoists that is designed to accommodate point loading. This hook is popular in ship and rail yards, where pulling operations can result in hook point loading.

Slip Clutch

Harrington offers a slip clutch device on our LB lever hoists which prevents the hoist from being used to lift damaging loads beyond rated capacity. This factory installed slip clutch is available on 3/4, 1 1/2, 3 and 6 Ton capacities. Hoists with the slip clutch are clearly marked and the free knob is black in color to easily identify the installation of this option.

Inspection Hooks

Harrington's inspection hook is suitable for applications where inspection of the internal parts of the hook set is required. The inspection hook uses the standard Harrington hook set and is assembled with high-strength locking fasteners instead of rivets. Inspection hooks are available in top and bottom versions for single fall LB, CB, CF, and NTH model hoists.

Bullard® and Shur-Loc® Hooks

These hooks offer a positive locking latch feature. Consult Customer Service for full details.



Load Limit Warning Handle



Top Hook Extender



Point Load Hooks



Slip Clutch

Heavy Duty Carrying Case

Harrington offers a rugged carrying case for the LX003-5 Mini Puller. This case provides convenient hoist access and protects the hoist while on a tool belt or when storing the hoist in a toolbox.

- Constructed of canvas material for durability
- Convenient belt loop for easy tool belt attachment
- Velcro flap for quick access
- Lightweight for user comfort
- Case is available for 1/4 Ton model



Technical Information

Compliance

Harrington's LB and LX lever hoists are produced to comply with:

- ANSI/ASME B30.21, "Safety Standard—Manually Lever Operated Hoists."
- ANSI/ASME HST—3M, "Performance Standard for Manually Lever Operated Chain Hoists."

Harrington's CF, CB and CX hand chain hoists and NTH trolley hoist are produced to comply with:

- ANSI/ASME B30.16, "Safety Standard—Overhead Hoists (Underhung)."
- ANSI/ASME HST—2M, "Performance Standard for Hand Chain Manually Operated Chain Hoists."

Harrington's PT and GT manual trolleys and NTH trolley hoist are produced to comply with the trolley-related requirements of:

- OSHA Section 1910.179 of Title 29, "Occupational Safety and Health Regulations—Overhead and Gantry Cranes."
- ANSI/ASME B30.11, "Safety Standard—Monorails and Underhung Cranes."
- ANSI/ASME B30.17, "Safety Standard—Overhead and Gantry Cranes (Top Running Bridge, Single Girder, Underhung Hoist)."

LB TOP AND BOTTOM HOOK — DIMENSIONS

Cap. (Tons)	a (in)	b (in)	c (in)	d (in)	e (in)	f (in)	g (in)	h (in)
3/4	0.9	0.6	0.8	0.6	1.4	1.4	0.93	3.2
1	0.9	0.6	0.8	0.6	1.7	1.7	1.14	3.7
1 1/2	1.2	0.7	1.0	0.7	1.7	1.8	1.26	4.1
2-2 3/4	1.4	0.8	1.14	0.8	1.9	2.0	1.44	4.7
3	1.6	1.0	1.2	1.0	2.0	2.2	1.54	5.0
6	2.1	1.3	1.6	1.3	2.4	2.7	1.97	6.2
9	2.6	1.6	2.0	1.6	3.4	3.5	2.85	8.5

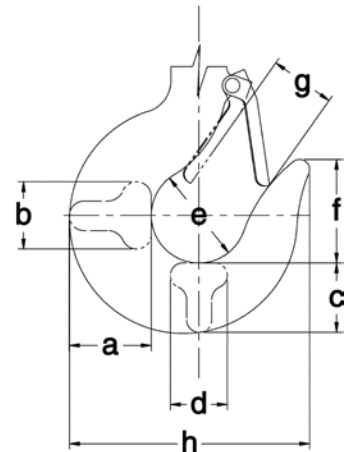

CB TOP AND BOTTOM HOOK — DIMENSIONS

Cap. (Tons)	a (in)	b (in)	c (in)	d (in)	e (in)	f (in)	g (in)	h (in)
1/2	0.8	0.5	0.7	0.5	1.4	1.4	1.1	3.0
1	1.0	0.6	0.9	0.6	1.7	1.6		3.7
1 1/2	1.2	0.8	1.0	0.8	1.9	1.9	1.3	4.2
2	1.4	0.9	1.2	0.9	2.0		1.4	4.6
2 1/2	1.6	1.0	1.3	1.0	2.1	2.1	1.6	5.0
3	1.8	1.1	1.5	1.1	2.2	2.2	1.7	5.4
5	2.2	1.4	1.9	1.4	2.5	2.7	1.8	6.3
8	3.0	1.9	2.5	1.9	3.3	3.8	2.9	9.1
10								
15	3.7	2.4	3.1	2.4	3.9	4.3	3.1	10.8
20	4.2	2.6	3.5	2.6	4.3	4.9	3.2	11.9
30	5.2	3.3	4.4	3.3	4.9	5.6	4.1	14.4
40	5.9	3.7	4.9	3.7	5.5	6.3		16.5
50	6.7	4.2	5.5	4.2	6.1	7.0	4.4	18.4
80	—	5.7	8.0	5.7	7.5	10.0	5.1	21.9
100		8.3	9.8	8.3	9.4	12.2	7.3	28.0

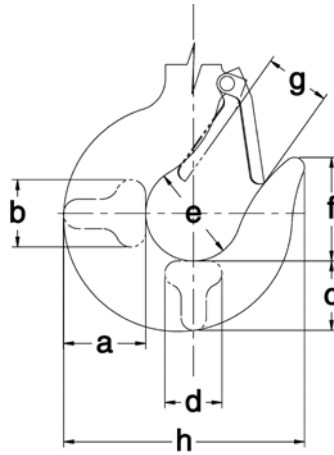

Hook diagram applies to all charts on page.

CF TOP AND BOTTOM HOOK — DIMENSIONS

Cap. (Tons)	a (in)	b (in)	c (in)	d (in)	e (in)	f (in)	g (in)	h (in)
1/2	0.8	0.5	0.7	0.5	1.4	1.4	1.1	3.0
1	1.0	0.6	0.9	0.6	1.7	1.6		3.7
1 1/2	1.2	0.8	1.0	0.8	1.9	1.9	1.3	4.2
2	1.4	0.9	1.2	0.9	2.0		1.4	4.6
3	1.8	1.1	1.5	1.1	2.2	2.2	1.7	5.4
5	2.2	1.4	1.9	1.4	2.5	2.7	1.8	6.3

NTH BOTTOM HOOK — DIMENSIONS

Cap. (Tons)	a (in)	b (in)	c (in)	d (in)	e (in)	f (in)	g (in)	h (in)
1	1.0	0.6	0.9	0.6	1.7	1.6	1.1	3.7
2	1.4	0.9	1.2	0.9	2.0	1.9	1.4	4.6
3	1.8	1.1	1.5	1.1	2.2	2.2	1.7	5.4
5	2.2	1.4	1.9	1.4	2.5	2.7	1.8	6.3

LX TOP AND BOTTOM HOOK — DIMENSIONS

Cap. (Tons)	a (in)	b (in)	c (in)	d (in)	e (in)	f (in)	g (in)	h (in)
1/4	0.57	0.43	0.49	0.43	1.26	1.18	0.80	2.55
1/2	0.69	0.47	0.59	0.47	1.40	1.37	0.90	2.90

CX TOP AND BOTTOM HOOK — DIMENSIONS

Cap. (Tons)	a (in)	b (in)	c (in)	d (in)	e (in)	f (in)	g (in)	h (in)
1/4	0.57	0.43	0.49	0.43	1.26	1.18	0.80	2.55

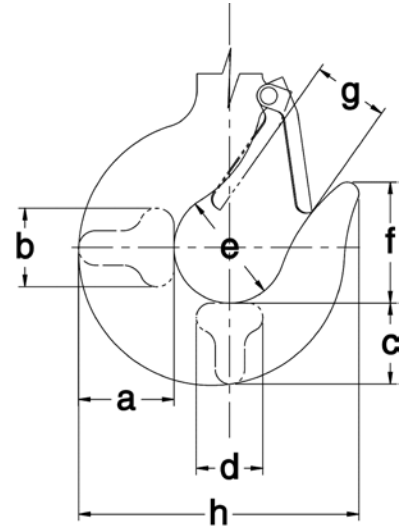

Hook diagram applies to all charts on page.

Glossary

Capacity:

The maximum load a hoist is designed to lift or pull. Commonly expressed in Tons. (1 Ton = 2,000 lbs.)

Chain Fall Lines:

The number of lines of chain between the hoist body and bottom hook. Also referred to as "reeves."

Grade 100 Load Chain:

Load chain used only on manual chain hoists, where the grade number indicates the relative strength of the chain for its size (i.e., larger grade numbers indicate stronger chain).

Hand Chain:

The chain that the operator pulls to lift or lower the load.

Hand Chain Drop:

On drawings in this catalog, hand chain drop is dimension 'd' for hoists and 'f' for trolleys. Hand chain drop is a measure of how low the hand chain hangs. For a hoist, it is how low the hand chain hangs measured from the hoist's top hook. For a hoist suspended from a trolley, it is how low the hand chain hangs measured from the bottom of the beam that the trolley rides on.

Headroom:

On drawings in this catalog, headroom is indicated by dimension 'C'. It is measured when the hoist's bottom hook is in its uppermost position. For a hoist, headroom is the distance between the top and bottom hooks. For a hoist suspended from a trolley, headroom is the distance from the bottom of the beam to the bottom hook.

Hook Parts:

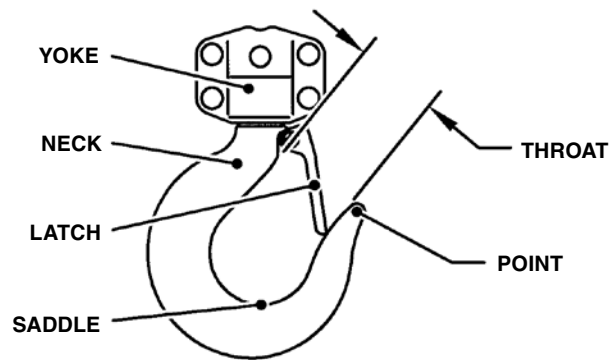

Lift:

The maximum distance the bottom hook can travel.

Load Chain:

The hoist's load bearing chain.

Glossary (cont.)

Minimum Radius for Curve:

Defines the sharpest curve of a beam on which the trolley can operate.

Nickel-Diffused (ND) Chain:

Specially treated chain that has a surface layer of nickel for enhanced resistance to corrosion. The nickel penetrates the base metal, providing a bond superior to plating.

Overhaul Ratio:

The distance in feet that the hand chain must travel to lift or lower the load a distance of 1 foot.

Pawl:

A component of the Weston brake that prevents rotation, thereby holding the load.

Point Loading:

A condition where part of the load applied to the hook is supported by the hook's point, or tip. Such applications require a hook designed for point loading.

Pull to Lift Load:

The force in pounds required by the operator to lift a rated capacity load.

Split Load Double Reduction Gears:

A gear train in which the load is supported by two sets of gears, with each gear set incorporating two gear reductions.

Suspender:

A load bearing component designed to connect a hoist to a trolley.

Test Load:

The load applied to the hoist to confirm proper operation in accordance with ASME B30.16 and ASME B30.21 test requirements.

Weston Brake:

A mechanical brake that allows operation of the hoist to lift, lower, or move the load, yet securely holds the load in between hoist operations.