

25-LREZ

The Model 25-LREZ is a belt driven live roller conveyor designed for use where zero pressure accumulation, low elevation (12") and close roller centers are required.

Heavy Duty Accumulating Conveyor

- EZLogic® Accumulation System
- Compact Drive
- Low Elevation
- Adjustable LRAS-Type Floor Supports Available

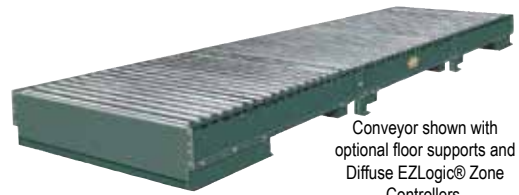

Conveyor shown with optional floor supports and Diffuse EZLogic® Zone Controllers.

SIZE TO ORDER Overall Length "A"	Between Rail Width	39"	41"	43"	45"	47"	49"	51"	61"
	Overall Frame Width	42"	44"	46"	48"	50"	52"	54"	64"
10'	WEIGHTS (Lbs.)	1261	1296	1331	1366	1400	1435	1470	1645
15'		1764	1815	1867	1918	1970	2021	2072	2329
20'		2267	2335	2403	2471	2538	2606	2674	3014
25'		2770	2854	2939	3023	3107	3192	3276	3698
30'		3272	3373	3474	3575	3675	3776	3877	4382
35'		3776	3893	4011	4128	4245	4363	4480	5067
40'		4279	4413	4547	4680	4814	4948	5082	5751
45'		4781	4931	5082	5232	5382	5533	5683	6435
50'		5284	5451	5618	5784	5951	6118	6285	7119

All weights in catalog are conveyor weights only. Accessories, crating, etc., are not included. Overall lengths in chart are for 60" zones. Other zone lengths will affect overall length.

**ACCUMULATION ZONE LENGTHS		
3" Roller Centers	4" Roller Centers	6" Roller Centers
*30"		*30"
*36"	*32"	*36"
*42"	*40"	*42"
*48"	*48"	*48"
*54"	*56"	*54"
60"	60"	60"
66"	72"	66"
72"		72"

*MINIMUM INFEED DRIVE ZONE LENGTH IS 60" WITH 3", 4" & 6" ROLLER CENTERS.

**FRAME LENGTH AND OVERALL LENGTH CHANGE WITH ZONE LENGTH.

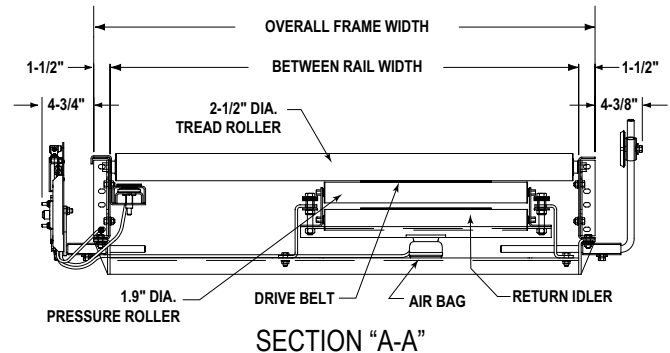
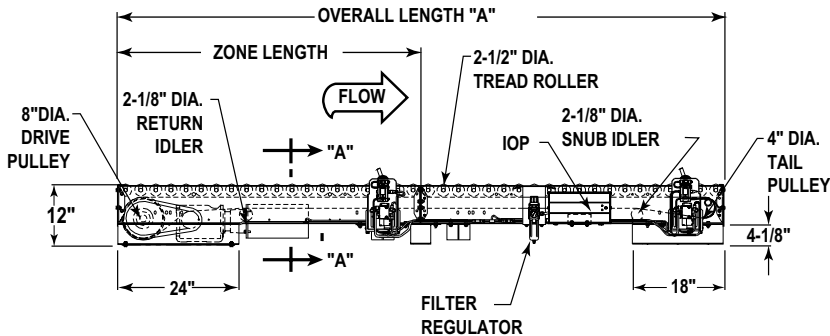

EZLOGIC

U.S. Patent Numbers
7,243,781 • 7,591,366
7,905,345
Other Patents Pending.



HOW IT WORKS

The conveyor is divided into accumulation zones. Each zone extracts power from flat drive belt that runs the entire length of the conveyor. Hytrol's EZLogic® Zone Controllers sense product presence and control the accumulation and release of product from the zones.



• STANDARD SPECIFICATIONS

BELT—14 in. black Ultimate 140 SD.

BED—Roller bed with 2 ½ in. dia. x 11 ga. unplated tread rollers spaced every 3 in. and 1.9 in. dia. x 16 ga. unplated pressure rollers spaced every 6 in. Mounted in 7 ½ in. x 10 ga. powder painted formed steel channel frame. Bolted together with butt coupling.

END DRIVE—Located on infeed end of conveyor.

DRIVE PULLEY—8 in. dia. with 1 ¾ in. dia. shaft at bearings, machine crowned and fully lagged.

TAIL PULLEY—4 in. dia. with 1 in. dia. shaft, machine crowned.

SNUB IDLER—Adjustable 2 ¾ in. dia. at drive pulley, 2 ½ in. dia. at tail pulley. Pre-lubricated ball bearings.

RETURN IDLER—2 ½ in. dia. at drive end, all others 1.9 dia. unplated. Pre-lubricated ball bearings.

TAKE-UP—Take-up at tail pulley.

BEARINGS—Sealed, pre-lubricated, self-aligning ball bearings on drive and tail pulley. Sealed, pre-lubricated ball bearings in tread and pressure rollers.

ACCUMULATION ZONES—3 in. roller centers, 30 in. to 72 in. on 3 in. increments. 4 in. roller centers, 32 in. to 72 in. on 4 in. increments. 6 in. roller centers, 30 in. to 72 in. on 6 in. increments. Minimum length of infeed zone (drive) is 60 in. Frame length changes with zone length.

EZLOGIC® ACCUMULATION SYSTEM

Hytrol's EZLogic®, or "Electronic Zero-pressure Logic" Accumulation System, combines the sensing accuracy of photo-electronics with discrete electronic logic control without the use of a PLC or pneumatic logic components. The EZLogic® Accumulation System provides many features including:

Zero-Pressure Accumulation of Product

Zone Stop function is built in. Any zone may be transformed into a workstation by connecting a dry contact switching device to the auxiliary port of the EZLogic® Zone Controller. This feature is always used at the discharge end of the conveyor line, and may be used at any other location where a zone stop is required.

Selectable Modes of Operation

Singulation Mode – Product separates while traveling down the conveyor and when it is released from the conveyor – creating a zone-length gap between products.

Enhanced Slug Mode w/ Jam Protection – Product does not separate when traveling down the conveyor or when it is released from the conveyor. This allows higher product throughput at any given conveyor speed. Product will not separate on the conveyor even when accumulation has been activated at the discharge end.

Cascaded Slug Release – Rather than releasing all zones simultaneously, this function introduces a momentary delay in the release of each zone, from discharge upstream.

Dynamic Zone Allocation – Automatically adjusts the conveyor's zone length to accommodate the length of the product being conveyed. Improves conveyor efficiency and system flexibility.

TREAD ROLLER BRAKE—Friction type brake stops tread rollers to prevent coasting of product in accumulation zone.

EZLogic® ZONE CONTROLLER—Located in each zone (Retro-reflective). NEMA 1, 2, IP 62. UL Approved.

IOP—Provides 27VDC, 100 watt power for EZLogic® accumulation system - contains slots for 4 input/output boards. Requires 120VAC or 230VAC single phase input.

AIR REQUIREMENTS—Recommended working pressure 40 P.S.I. Free air consumption at 40 P.S.I.—.028 cu. ft. per sensor actuation.

FILTER, REGULATOR—Supplied for main air supply line. (¾ in. NPT port).

SPEED REDUCTION—Sealed Helical—Bevel C-Face gear reducer. No.60 roller chain to drive pulley.

MOTOR—1 HP—208/230/460/575V—3 PH. 60 Hz. Totally Enclosed C-Face.

CONVEYING SPEED—Constant 30 FPM.

CAPACITY—Maximum load per linear foot of conveyor 1000 lbs. Maximum unit load 4000 lbs. Total load NOT TO EXCEED capacity in charts.

FLOOR SUPPORTS—Now supplied as optional equipment.

LOAD CAPACITY CHART (Accumulated) @ 30 FPM						
HP	OVERALL FRAME WIDTH 42" TO 48"		OVERALL FRAME WIDTH 50" TO 64"		OVERALL FRAME WIDTH 76" TO 88"	
	TOTAL LOAD (LBS.)		TOTAL LOAD (LBS.)		TOTAL LOAD (LBS.)	
	UP TO 25'	UP TO 50'	UP TO 25'	UP TO 50'	UP TO 25'	UP TO 50'
1	16500	12900	15400	10800	13700	7500
2	*20000	23000	*20000	20900	*20000	17600

*Limited to 4000# Per Accumulation Zone

NOTE: Operating 25-LREZ in slug mode is not recommended

NOTE: Product footprint may affect drive capacity.

• OPTIONAL EQUIPMENT

FLOOR SUPPORTS—LRAS Type floor supports are available with a wide range of adjustment. Specify top of belt or roller elevation. One support required at every bed joint and ends of conveyor. Holes in feet for lagging to floor.

CONVEYING SPEED—Other constant speeds to 50 FPM. **Note:** Capacity and accumulation feature affected with speed change.

UNDERSIDE TAKE-UP—Provides 12 in. of belt take-up. Minimum elevation 12 in. (Required on units 40 ft. or longer.) Must be located in 4 ft. long intermediate section.

O-RING DRIVE CHAIN—With sealed in lubricant (Recommended for applications that do not permit regular lubrication).

TREAD ROLLERS—2 ¾ in. dia. x 7 ga. unplated steel, 1 ¼ in. hex spring loaded shaft.

MOTORS—Energy efficient, single phase, other characteristics. 2 HP maximum.

ELECTRICAL CONTROLS—Non-reversing magnetic starter – push-button stations. AC variable frequency drive.

EZLogic® – See EZLogic® Components Page.

